



Model 119 ▲



The Model 119 has a very specific purpose: to shut off the flow of fuel through a filter separator in the event of high water levels in the filter separator sump. To perform this task, the Model 119 must operate in conjunction with one of the OCV 800 series interface float pilots.

SERIES FEATURES

- ▶ High capacity pilot system provides quick closing
- ▶ Can be maintained without removal from the line
- ▶ Factory tested
- ▶ Valve position indicator

OPERATION

With little or no water in the sump of the filter separator, the float of the interface pilot is down. The float pilot routes vessel pressure to the bonnet of the three-way auxiliary pilot. This positions the three-port auxiliary pilot to connect the bonnet of the main valve downstream, allowing the valve to open.

With a high water level in the sump of the filter separator, the float of the interface pilot is up. The float pilot vents pressure from the bonnet of the three-way auxiliary pilot, shifting it to apply full inlet pressure to the bonnet of the main valve and drives the valve fully and tightly closed.

COMPONENTS

The Model 119 consists of the following components, arranged as shown on the schematic diagram:

- 1.) Model 65 Basic Control Valve (Fail Closed)
- 2.) Model A224 Accelerator Pilot
- 3.) 123 Inline Strainer
- 4.) Model 155L Visual Indicator

SCHEMATIC

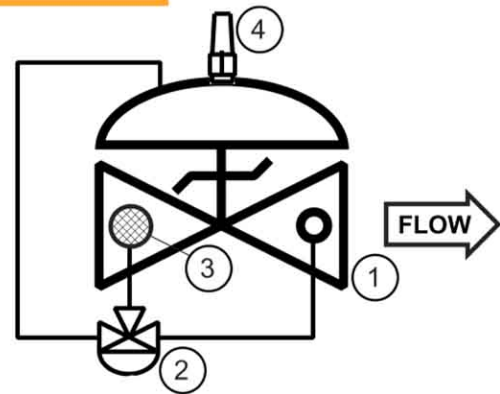

MODEL 119

RECOMMENDED INSTALLATION

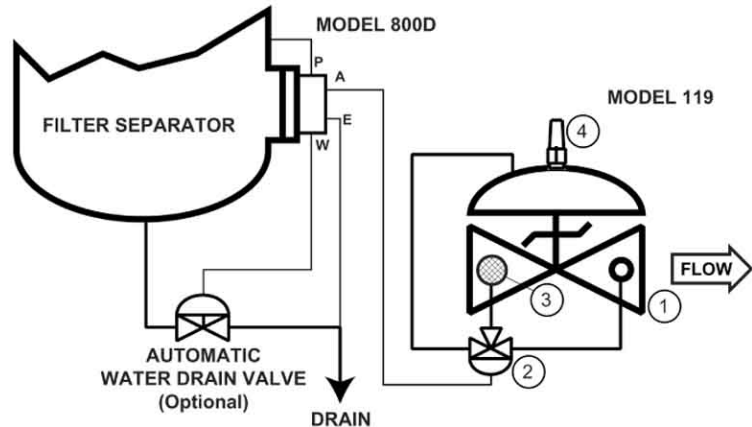

— INDICATES FIELD-CONNECTED LINES, 1/4" OD STAINLESS STEEL TUBING TYP.

SIZING

Sizing of the Model 119 is typically the same size as the filter separator discharge connection. Consult the factory for assistance.

MAX. PRESSURE

END CONNECTIONS	DUCTILE IRON	STEEL WCB	STEEL LCB	Stn. St. CF8M	ALUMINUM
Threaded	20.7 bar	20.7 bar	20.7 bar	20.7 bar	19.7 bar
Grooved	20.7 bar	20.7 bar	20.7 bar	20.7 bar	13.8 bar
150# Flanged	17.2 bar	19.7 bar	19.7 bar	19.7 bar	19.7 bar
300# Flanged	20.7 bar	20.7 bar	20.7 bar	20.7 bar	----

phone: (918)627.1942 • fax: (918)622.8916 • 7400 East 42nd Place, Tulsa, OK 74145
 email: sales@controlvalves.com • website: www.controlvalves.com

SIZES

GLOBE/ANGLE

Screwed Ends: 1 1/4" - 3" (DN32 thru DN80)
Grooved Ends: 1 1/2" - 6" (DN40 thru DN150)
Flanged Ends:

1 1/4" - 24" (DN32 thru DN600) (globe);
1 1/4" - 16" (DN32 thru DN400) (angle)

TEMPERATURE RANGE

(Valve Elastomers)

Buna-N -40° C - 82° C

Viton -17° C - 204° C

MATERIALS

Consult factory for others.

Body/Bonnet: Ductile Iron (epoxy coated), Carbon Steel (epoxy coated), Stainless Steel, Aluminum

Seat Ring: Stainless Steel, Bronze

Stem: Stainless Steel, Monel

Spring: Stainless Steel

Diaphragm: Buna-N, Viton, (Nylon reinforced)

Seat Disc: Buna-N, Viton

Pilot: Stainless Steel, Bronze

Other pilot system components:

Stainless Steel, Bronze/Brass

Tubing & Fittings: Stainless Steel, Copper/Brass

SPECIFICATIONS (Typical Fuel Application)

The filter separator shut-off valve shall open and close via hydraulic signals from the interface float pilot.

DESIGN

The filter separator shut-off valve shall be a single-seated, line pressure operated, diaphragm actuated, pilot controlled globe valve. The valve shall seal by means of a corrosion-resistant seat and a resilient, rectangular seat disc. These, and other parts, shall be replaceable without removing the valve from the line. The stem of the main valve shall be guided top and bottom by integral bushings. Alignment of the body, bonnet and diaphragm assembly shall be by precision dowel pins. The diaphragm shall not be used as a seating surface, nor shall the pistons be used as an operating means. The pilot system shall be furnished complete and installed on the main valve. It shall include an inline strainer, 3-way auxiliary pilot, and valve position indicator. The filter separator shut-off valve shall be operationally and hydrostatically tested prior to shipment.

MATERIALS OF CONSTRUCTION

The main valve body and bonnet shall be ductile iron per ASTM A536, Grade 65-45-12. All ferrous surfaces shall be coated with 4 mils of epoxy. The main valve seat ring shall be CF8M stainless steel. Elastomers (diaphragms, resilient seats and O-rings) shall be Buna-N. The auxiliary pilot, control line tubing and fittings shall be stainless steel.

OPERATING CONDITIONS

The filter separator shut-off valve shall be suitable for pressures of <X to X> bar at flow rates up to <X> m³/hr.

ACCEPTABLE PRODUCTS

The filter separator shut-off valve shall be a <size> Model 119, <globe pattern, angle pattern>, with <150# flanged, 300# flanged, threaded, grooved> end connections, as manufactured by OCV Control Valves, Tulsa, Oklahoma, USA.

METRIC DIMENSIONS - M.M.

DIM	END CONN.	DN32-DN40	DN50	DN65	DN80	DN100	DN150	DN200	DN250	DN300	DN350	DN400	DN600
A	SCREWED	222	251	267	330	--	--	--	--	--	--	--	--
	GROOVED	222	251	267	330	387	508	--	--	--	--	--	--
	150# FLGD	216	238	267	305	381	451	645	756	864	991	1026	1575
	300# FLGD	222	251	283	324	397	473	670	791	902	1029	1067	1619
C ANGLE	SCREWED	111	121	152	165	--	--	--	--	--	--	--	--
	GROOVED	111*	121	152	165	194	--	--	--	--	--	--	--
	150# FLGD	108	121	152	152	191	254	322	378	432	--	529	--
	300# FLGD	111	127	162	162	198	267	335	395	451	--	549	--
D ANGLE	SCREWED	79	98	102	114	--	--	--	--	--	--	--	--
	GROOVED	79*	98	102	114	143	--	--	--	--	--	--	--
	150# FLGD	76	98	102	102	140	152	203	289	279	--	398	--
	300# FLGD	79	105	111	111	148	165	216	306	298	--	419	--
E	ALL	152	152	178	165	203	254	302	391	432	457	483	686
F	ALL	98	98	98	98	98	98	162	162	162	162	162	203
H	ALL	254	279	279	279	305	330	356	432	457	508	508	724

*GROOVED END NOT AVAILABLE IN DN32

CE Markings

Applies to fuel valves installed in the European Union in accordance with the Pressure Equipment Directive, 97/23/EC

CE-marked valves are available in LCB steel and CF8M stainless steel only

OCV is registered to the PED through Det Norske Veritas

The following valves will be CE-marked:

- 6" (DN150) and larger valves, 150# and 300# class, liquid fuel only
- 2" (DN50) thru 4" (DN100) valves, 300# class, liquid fuel
- 1 1/4" (DN32) thru 4" (DN100) valves, 300# class, LPG or Butane service
- 4" (DN100) and smaller valves in Class 150# (liquids) are furnished under SEP with no CE-mark

For maximum efficiency, the OCV control valve should be mounted in a piping system so that the valve bonnet (cover) is in the top position. Other positions are acceptable but may not allow the valve to function to its fullest and safest potential. In particular, please consult the factory before installing 8" (DN200) and larger valves, or any valves with a limit switch, in positions other than described. Space should be taken into consideration when mounting valves and their pilot systems.

A routine inspection & maintenance program should be established and conducted yearly by a qualified technician. Consult our factory @ **1-918-627-1942** for parts and service.

How to order your Model 119 valve

When ordering please provide:

Fluid to be controlled - Model Number - Size - Globe or Angle - End Connection - Body Material - Trim Material - Elastomers - Special Requirements/ Installation Requirements

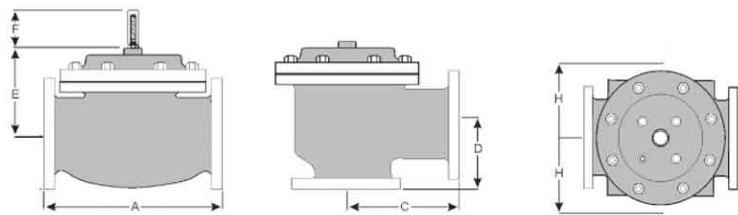

QUALITY SYSTEM
REGISTERED TO
ISO 9001

phone: (918)627.1942 • fax: (918)622.8916 • 7400 East 42nd Place, Tulsa, Oklahoma 74145
email: sales@controlvalves.com • website: www.controlvalves.com