

The Model 108-2 has a wide range of applications: anywhere a system must be protected from pressures that are too high (relief) or too low (sustaining). Typical applications include:

- ▶ Pump systems
- ▶ Fuel distribution systems

SERIES FEATURES

- ▶ Relief Valve: Limits inlet pressure by relieving excess pressure
- ▶ Pressure Sustaining: Prevents inlet pressure from dropping below a predetermined minimum
- ▶ Operates over a wide flow range
- ▶ Inlet pressure is adjustable with a single screw
- ▶ Quick opening; adjustable closing speed
- ▶ Can be maintained without removal from the line
- ▶ Factory tested and can be pre-set to your requirements

OPERATION

The normally closed, spring-loaded pilot, sensing upstream pressure, responds to changes in pressure and causes the main valve to do the same. The net result is a constant modulating action of the pilot and main valve to hold the upstream pressure constant. The pilot system is equipped with a closing speed control that fine tunes the valve response to the system variables.

COMPONENTS

The Model 108-2 consists of the following components, arranged as shown on the schematic diagram:

- 1.) Model 65 Basic Control Valve
- 2.) Model 1330 Pressure Relief/Back Pressure Pilot
- 3.) Model 126 Ejector
- 4.) Model 141-3 Flow Control Valve
- 5.) Model 123 Inline Strainer
- 6.) Model 155L Visual Indicator (optional)

SIZING

Due to static electricity and other concerns, pressure sustaining valves and pressure relief valves that operate frequently should be limited to a maximum velocity of 3 meters/second. Pressure relief valves that operate intermittently may be extended to 6 meters/second

Please consult factory for definitive sizing assistance.

SIZE, DN	32-40	50	65	80	100	150	200	250	300	350	400	600
FLOW@3 M/S, M ³ /HR	10-15	24	34	52	91	205	355	560	795	955	1250	2840
FLOW@6 M/S, M ³ /HR	27	45	64	105	182	409	681	954	1363	1635	2180	6359

Cavitation Note: Relief valves, by their application, are subject to pressure differentials that may induce cavitation. When these conditions exist, it may be only on an intermittent basis, causing minimum concern for valve deterioration. Charts indexing only inlet and outlet pressures do not address the complexity of this phenomenon. OCV can assist you in validating your application.

SCHEMATIC

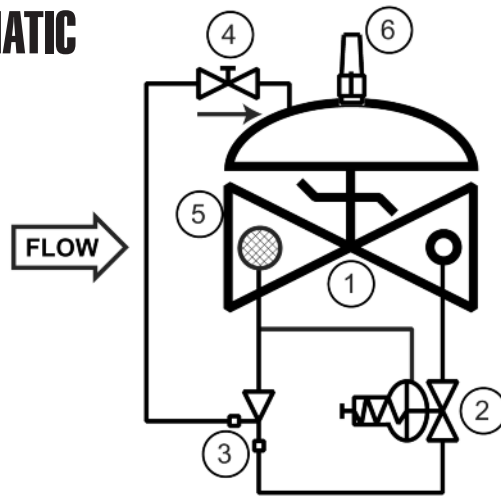

RECOMMENDED INSTALLATION

- ▶ Install the valve with adequate space above and around the valve to facilitate servicing. Refer to the Dimension Table.
- ▶ Valve should be installed with the bonnet (cover) at the top, particularly 8" (DN200) and larger valves, and any valve with a limit switch.
- ▶ Shut-off valves should be installed upstream and downstream of the control valve. These are used to isolate the valve during start-up and maintenance.
- ▶ Install a pressure gauge upstream of the valve to enable adjustment to the required pressure setting. This gauge may be installed in the upstream side port of the valve body.

MAX. PRESSURE

END CONNECTIONS	DUCTILE IRON	STEEL WCB	STEEL LCB	Stn. Stl. CF8M	ALUMINUM
Threaded	44.1 bar	44.1 bar	44.1 bar	44.1 bar	19.7 bar
Grooved	20.7 bar	20.7 bar	20.7 bar	20.7 bar	13.8 bar
150# Flanged	17.2 bar	19.7 bar	18.4 bar	19.0 bar	19.7 bar
300# Flanged	44.1 bar	51.0 bar	48.0 bar	49.6 bar	----

phone: (918)627.1942 • fax: (918)622.8916 • 7400 East 42nd Place, Tulsa, OK 74145
 email: sales@controlvalves.com • website: www.controlvalves.com

SIZES

GLOBE/ANGLE

Screwed Ends: 1 1/4" - 3" (DN32 thru DN80)

Grooved Ends: 1 1/2" - 4" (DN40 thru DN150)

Flanged Ends:

1 1/4" - 24" (DN32 thru DN600) (globe);

1 1/4" - 16" (DN32 thru DN400) (angle)

TEMPERATURE RANGE

(Valve Elastomers)

Buna-N -40° C - 82°C

Viton -17°C - 204°C

SPRING RANGES (inlet setting)

0.3-2.1 bar; 1.4-5.5 bar; 4.5-12.4 bar;

6.9-20.7 bar

MATERIALS

Consult factory for others.

Body/Bonnet: Ductile Iron (epoxy coated), Carbon

Steel (epoxy coated), Stainless Steel, Aluminum

Seat Ring: Stainless Steel, Bronze

Stem: Stainless Steel, Monel

Spring: Stainless Steel

Diaphragm: Buna-N, Viton,

(Nylon reinforced)

Seat Disc: Buna-N, Viton

Pilot: Stainless Steel, Bronze

Other pilot system components: Stainless Steel,

Bronze/Brass

Tubing & Fittings:

Stainless Steel, Copper/Brass

SPECIFICATIONS (Typical Fuel Application)

The <pressure relief><pressure sustaining> valve shall function to <prevent main pressure from exceeding a predetermined maximum><prevent the upstream pressure from falling below a predetermined minimum.>

DESIGN

The valve shall be a single-seated, line pressure operated, diaphragm actuated, pilot controlled <globe><angle> valve. The valve shall seal by means of a corrosion-resistant seat and a resilient, rectangular seat disc. These, and other parts, shall be replaceable without removing the valve from the line. The stem of the main valve shall be guided top and bottom by integral bushings. Alignment of the body, bonnet, and diaphragm assembly shall be by precision dowel pins. The diaphragm shall not be used as a seating surface, nor shall pistons be used as an operating means. The pilot system shall be furnished complete and installed on the main valve. It shall include a closing speed control and an inline strainer. The <pressure relief><pressure sustaining> valve shall be operationally and hydrostatically tested prior to shipment.

MATERIALS OF CONSTRUCTION

The main valve body and bonnet shall be ductile iron per ASTM A536, Grade 65-45-12. All ferrous surfaces shall be coated with 4 mils of epoxy. The main valve seat ring shall be CF8-M stainless steel. Elastomers (diaphragm, resilient seats, and O-rings) shall be Buna-N. Control pilots shall be CF8-M stainless steel. The closing speed control shall be stainless steel, as shall the control line tubing and fittings.

OPERATING CONDITIONS

The <pressure relief><pressure sustaining> valve shall be suitable for controlling the inlet pressure to a <maximum><minimum> of <X> bar at flow rates ranging from <Y to Z> m³/hr.

ACCEPTABLE PRODUCTS

The <pressure relief><pressure sustaining> valve shall be a <SIZE> Model 108-2, <globe pattern><angle pattern> with <150# flanged><300# flanged><threaded><grooved> end connections, as manufactured by OCV Control Valves, Tulsa, Oklahoma, USA.

METRIC DIMENSIONS - M.M.

DIM	END CONN.	DN32-DN40	DN50	DN65	DN80	DN100	DN150	DN200	DN250	DN300	DN350	DN400	DN600
A	SCREWED	222	251	267	330	--	--	--	--	--	--	--	--
	GROOVED	222	251	267	330	387	508	--	--	--	--	--	--
	150# FLGD	216	238	267	305	381	451	645	756	864	991	1026	1575
	300# FLGD	222	251	283	324	397	473	670	791	902	1029	1067	1619
C ANGLE	SCREWED	111	121	152	165	--	--	--	--	--	--	--	--
	GROOVED	111*	121	152	165	194	--	--	--	--	--	--	--
	150# FLGD	108	121	152	152	191	254	322	378	432	--	529	--
	300# FLGD	111	127	162	162	198	267	335	395	451	--	549	--
D ANGLE	SCREWED	79	98	102	114	--	--	--	--	--	--	--	--
	GROOVED	79*	98	102	114	143	--	--	--	--	--	--	--
	150# FLGD	76	98	102	102	140	152	203	289	279	--	398	--
	300# FLGD	79	105	111	111	148	165	216	306	298	--	419	--
E	ALL	152	152	178	165	203	254	302	391	432	457	483	686
F	ALL	98	98	98	98	98	98	162	162	162	162	162	203
H	ALL	254	279	279	279	305	330	356	432	457	508	508	724

*GROOVED END NOT AVAILABLE IN DN32

CE Markings

Applies to fuel valves installed in the European Union in accordance with the Pressure

Equipment Directive, 97/23/EC

CE-marked valves are available in LCB steel and CF8M stainless steel only

OCV is registered to the PED through Det Norske Veritas

The following valves will be CE-marked:

- 6" (DN150) and larger valves, 150# and 300# class, liquid fuel only
- 2" (DN50) thru 4" (DN100) valves, 300# class, liquid fuel
- 1 1/4" (DN32) thru 4" (DN100) valves, 300# class, LPG or Butane service
- 4" (DN100) and smaller valves in Class 150# (liquids) are furnished under SEP with no CE-mark

For maximum efficiency, the OCV control valve should be mounted in a piping system so that the valve bonnet (cover) is in the top position. Other positions are acceptable but may not allow the valve to function to its fullest and safest potential. In particular, please consult the factory before installing 8" (DN200) and larger valves, or any valves with a limit switch, in positions other than described. Space should be taken into consideration when mounting valves and their pilot systems.

A routine inspection & maintenance program should be established and conducted yearly by a qualified technician. Consult our factory @ 1-918-627-1942 for parts and service.

How to order your Model 108-2 valve

When ordering please provide:

Fluid to be controlled - Model Number - Size - Globe or Angle - End Connection - Body

Material - Trim Material - Pilot Options - Flow Rate Setting or Range - Special

Requirements / Installation Requirements

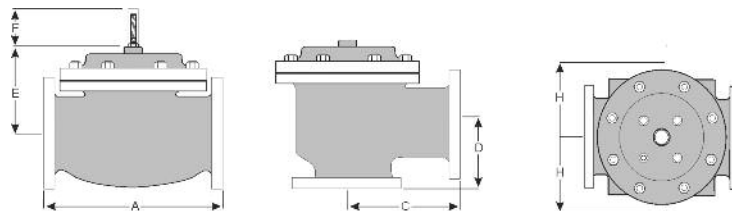

QUALITY SYSTEM
REGISTERED TO
ISO 9001

phone: (918)627.1942 • fax: (918)622.8916 • 7400 East 42nd Place, Tulsa, Oklahoma 74145

email: sales@controlvalves.com • website: www.controlvalves.com