

The Model 129FC automatically reduces high pressure in building riser pipe to a pressure that can be easily handled by the components it supplies.

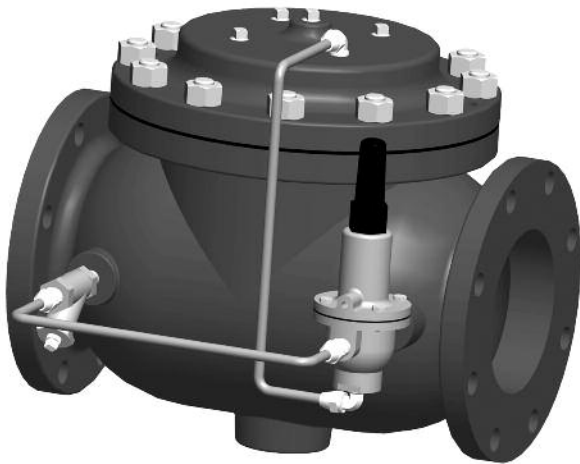

▲ Model 129FC

SERIES FEATURES

- ▶ Maintains constant discharge pressure despite variations in demand or inlet pressure. Eliminates pressure fall off
- ▶ Easily adjusted for discharge pressures ranging from 3.4 bar - 11.3 bar
- ▶ Fully operated by line pressure; no external power source required
- ▶ Soft seat for drip-tight closure
- ▶ Easily cleaned, repaired and adjusted without removal from the line
- ▶ Underwriters Laboratories listed, Control Number 18S5
- ▶ Diaphragm assembly guided top and bottom is the only moving part of the main valve
- ▶ UL / ULC Listed for pressure control service in sizes 1.5" (DN40) - 8" (DN200), globe or angle configuration
- ▶ No packing glands or stuffing boxes to service
- ▶ Horizontal or vertical mounting in all sizes
- ▶ ANSI Flanged Class 150 or Class 300
- ▶ Grooved end flanges available on 1.5" (DN40) - 6" (DN150)
- ▶ Screwed end flanges available on 1.5" (DN40), 2" (DN50), 2.5" (DN65) and 3" (DN80)
- ▶ Wide range of materials available
- ▶ Factory tested

OPERATION

The normally open, spring loaded pilot, sensing downstream pressure, responds to changes in pressure and causes the main valve to do the same. The net result is a constant modulating action of the pilot and main valve to hold the downstream pressure constant.

COMPONENTS

The Model 129FC consists of the following components, arranged as shown on the schematic diagram:

- 1.) **Model 65 Basic Control Valve**, a hydraulically-operated, diaphragm-actuated, globe or angle valve which closes with an elastomer-on-metal seal.
- 2.) **Model 1390 Pilot**, a three-way, normally-open pilot valve which senses downstream pressure under its diaphragm and balances it against an adjustable spring load. An increase in downstream pressure tends to make the pilot close.
- 3.) **Model 159 Y-Strainer**, protects the pilot system from solid contaminants in the line fluid.
- 4.) **Model 155 Visual Indicator Assembly** (optional), useful for indication of valve's position at a glance.

SIZING

Because the 129FC can experience a wide range of flow rates—ranging from zero, when the system is not being used, to the flow required by a single sprinkler, or full system demand—proper sizing is important. Use the smallest available valve that is consistent with the following maximum demand chart.

SCHEMATIC

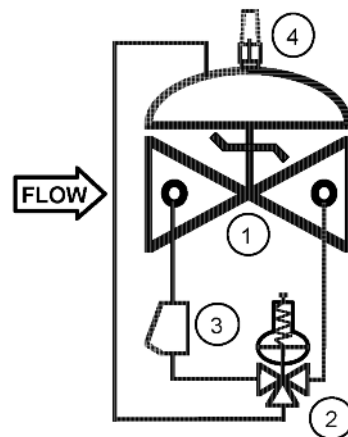

RECOMMENDED INSTALLATION

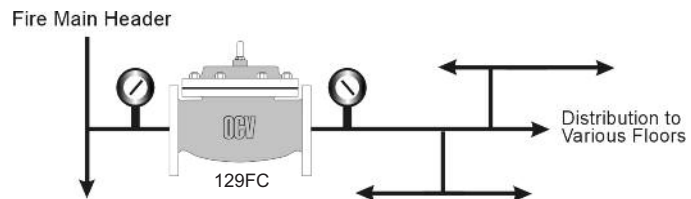

VALVE SIZE	MAX. FLOW, M ³ /HR
1.5" (DN40)	26
2" (DN50)	48
2 1/2" (DN65)	68
3" (DN80)	105
4" (DN100)	182
6" (DN150)	409
8" (DN200)	704

For more detailed information on sizing, see OCV's "PRV Sizing Guide" or the Performance Charts in the OCV catalog.

TOLL FREE 1.888.628.8258 • phone: (918)627.1942 • fax: (918)622.8916 • 7400 East 42nd Place, Tulsa, Ok 74145
 email: sales@controlvalves.com • website: www.controlvalves.com

SIZES

Globe or Angle - 1.5" (DN40), 2" (DN50), 2.5" (DN65), 3" (DN80), 4" (DN100), 6" (DN150), 8" (DN200)

MAX. WORKING PRESSURE

1.5" (DN40) - 3" (DN80) Screwed End: 20.7 bar
 1.5" (DN40) - 6" (DN150) Grooved End: 20.7 bar
 1.5" (DN40) - 8" (DN200) 150# ANSI: 17.2 bar
 1.5" (DN40) - 8" (DN200) 300# ANSI: 20.7 bar

TEMPERATURE RANGE

(Buna-N Elastomers)
 0°C - 82°C

MATERIALS

Body/Bonnet:

- Ductile Iron ASTM A536-epoxy coated (standard)
- Cast Steel ASTM A216 Grade WCB-epoxy coated
- Stainless Steel ASTM A743 CF8M
- Nickel Aluminum Bronze ASTM B148 Alloy C95800
- Duplex Stainless Steel

Seat Ring:

- Bronze (standard)
- Stainless Steel ASTM A743 CF8M (optional)
- Nickel Aluminum Bronze ASTM B148 Alloy C95800 (optional)
- Duplex Stainless Steel (optional)

Stem:

- Stainless Steel AISI 303 (standard)
- Monel (optional)

Spring:

- Stainless Steel AISI 302 (standard)
- Inconel (optional)

Diaphragm:

- Nylon Reinforced Buna-N

Pressure Reducing Pilot:

- Bronze (standard)
- Stainless Steel ASTM A743 CF8M (optional)
- Nickel Aluminum Bronze ASTM B148 Alloy C95800 (optional)
- Duplex Stainless Steel (optional)

Tubing/Fittings:

- Copper/Brass (standard)
- Stainless Steel (optional)
- Monel (optional)

OCV pressure control valves are UL/ULC Listed for mounting in the horizontal or vertical position. Space should be taken into consideration when mounting valves and their pilot systems.

A routine inspection & maintenance program should be established and conducted yearly by a qualified technician. Consult our factory @ 1-888-628-8258 for parts and service.

When ordering your 129FC,

please provide:
 Series Number - Valve size - Globe or Angle - Flanged 150#, 300# ANSI, screwed or grooved ends - Trim Material - Special needs / or Installation Requirements

SPECIFICATIONS

The pressure control valve shall function to reduce a higher inlet pressure to a constant lower outlet pressure regardless of variations in inlet pressure or demand.

DESIGN

The pressure control valve shall be a single-seated, line pressure operated, diaphragm actuated, pilot controlled globe or angle valve. The valve shall seal by means of a corrosion-resistant seat and resilient, rectangular seat disc. These and other parts shall be replaceable without removing the valve from the line. The stem of the main valve shall be guided top and bottom by integral bushings. Alignment of the body, bonnet and diaphragm assembly shall be by precision dowel pins. The diaphragm shall not be used as a seating surface, nor shall pistons be used as an operating means. The pilot system shall be furnished complete, installed on the main valve and include a Y-strainer.

MATERIALS OF CONSTRUCTION

The main valve body and bonnet shall be ductile iron per ASTM A536, Grade 65-45-12 (or other. Refer to Materials Chart). All internal ferrous surfaces shall be coated with 4 mils of epoxy. External surfaces shall be coated with 4 mils of epoxy followed by a coat of fire red enamel paint. The main valve seat ring shall be bronze (or other. Refer to Materials Chart). Elastomers (diaphragms, resilient seats, and O-rings) shall be Buna-N. Control pilot shall be bronze (or other. Refer to Materials Chart). The control line tubing shall be copper (or other. Refer to Materials Chart).

ACCEPTABLE PRODUCTS

The pressure control valve shall be a Model 129FC, UL / ULC Listed, as manufactured by OCV Control Valves, Tulsa, OK, USA

U.S. DIMENSIONS - INCHES

DIM	END CONN.	1 1/2	2	2 1/2	3	4	6	8
A	SCREWED	8 3/4	9 7/8	10 1/2	13	—	—	—
	GROOVED	8 3/4	9 7/8	10 1/2	13	15 1/4	20	—
	150# FLGD	8 1/2	9 3/8	10 1/2	12	15	17 3/4	25 3/8
	300# FLGD	8 3/4	9 7/8	11 1/8	12 3/4	15 5/8	18 5/8	26 3/8
B	SCREWED	1 7/16	1 11/16	1 7/8	2 1/4	—	—	—
	GROOVED	1*	1 3/16	1 7/16	1 3/4	2 1/4	—	—
	150# FLGD	2 5/16-2 1/2	3	3 1/2	3 3/4	4 1/2	5 1/2	6 3/4
	300# FLGD	2 5/8-3 1/16	3 1/4	3 3/4	4 1/8	5	6 1/4	7 1/2
C ANGLE	SCREWED	4 3/8	4 3/4	6	6 1/2	—	—	—
	GROOVED	4 3/8*	4 3/4	6	6 1/2	7 5/8	—	—
	150# FLGD	4 1/4	4 3/4	6	6	7 1/2	10	12 11/16
	300# FLGD	4 3/8	5	6 3/8	6 3/8	7 13/16	10 1/2	13 3/16
D ANGLE	SCREWED	3 1/8	3 7/8	4	4 1/2	—	—	—
	GROOVED	3 1/8*	3 7/8	4	4 1/2	5 5/8	—	—
	150# FLGD	3	3 7/8	4	4	5 1/2	6	8
	300# FLGD	3 1/8	4 1/8	4 3/8	4 3/8	5 13/16	6 1/2	8 1/2
E	ALL	6 3/4	6 3/4	7 7/8	7 3/4	9 3/4	11 1/2	14 1/2
F	ALL	3 7/8	3 7/8	3 7/8	3 7/8	3 7/8	3 7/8	6 3/8
G	ALL	6	6 3/4	7 11/16	8 3/4	11 3/4	14	21
H	ALL	10	11	11	11	12	13	14

METRIC DIMENSIONS - M.M.

DIM	END CONN.	DN40	DN50	DN65	DN80	DN100	DN150	DN200
A	SCREWED	222	251	267	330	—	—	—
	GROOVED	222	251	267	330	387	508	—
	150# FLGD	216	238	267	305	381	451	645
	300# FLGD	222	251	283	324	397	473	670
B	SCREWED	37	43	48	57	—	—	—
	GROOVED	25*	30	37	44	57	—	—
	150# FLGD	59-64	76	89	95	114	140	171
	300# FLGD	67-78	83	95	105	127	159	191
C ANGLE	SCREWED	111	121	152	165	—	—	—
	GROOVED	111*	121	152	165	194	—	—
	150# FLGD	108	121	152	152	191	254	322
	300# FLGD	111	127	162	162	198	267	335
D ANGLE	SCREWED	79	98	102	114	—	—	—
	GROOVED	79*	98	102	114	143	—	—
	150# FLGD	76	98	102	102	140	152	203
	300# FLGD	79	105	111	111	148	165	216
E	ALL	171	171	200	197	248	292	368
F	ALL	98	98	98	98	98	98	162
G	ALL	152	171	195	222	298	356	533
H	ALL	254	279	279	279	305	330	356

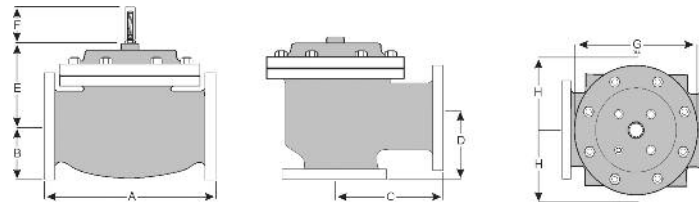

QUALITY SYSTEM REGISTERED TO ISO 9001

Represented by: