



▲ Pump Suction Control Valve

The Model 108FPS is used to prevent the fire pump from outdrawing the available supply. In so doing, it protects the pump suction supply from damage associated with too low a pressure and assures adequate supply pressure to the fire system components.

SERIES FEATURES

- ▶ Maintains minimum pump suction pressure
- ▶ Installs on fire pump discharge; senses pump suction
- ▶ Suction pressure is adjustable with single screw
- ▶ Adjustable .34 - 2.0 bar range
- ▶ Sizes 3" (DN80) - 8" (DN200), globe and angle
- ▶ Pilot-operated main valve
- ▶ Maintain without removal from the line
- ▶ Adjustable opening speed
- ▶ Factory tested and can be pre-set to your requirements
- ▶ Factory Mutual Approved

OPERATION

The normally closed, spring loaded pilot, sensing pump suction pressure, opens when supply pressure exceeds the spring setting, allowing the main valve to open. Should suction pressure lower to the set point, the pilot, hence the main valve will begin modulating (throttling) to prevent the suction pressure from falling any lower. The pilot system is equipped with an opening speed control that fine tunes the valve response to the system variables.

COMPONENTS

The Model 108FPS consists of the following components, arranged as shown on the schematic diagram:

- 1.) **Model 65 Basic Control Valve**, a hydraulically-operated, diaphragm-actuated, globe or angle valve which closes with an elastomer-on-metal seal.
- 2.) **Model 1330HB Pressure Relief Pilot**, a two-way, normally-closed pilot valve which senses upstream pressure under its diaphragm and balances it against an adjustable spring load. An increase in upstream pressure tends to make the pilot open.
- 3.) **Model 126 Ejector**, a simple "tee" fitting with a fixed orifice in its inlet port. It provides the proper pressure to the diaphragm chamber of the main valve depending on the position of the pressure relief pilot.
- 4.) **Model 141-3 Flow Control Valve**, a needle-type valve which provides adjustable, restricted flow in one direction, and free flow in the opposite direction. On the 108FPS, the flow control valve is connected as an **opening speed control**.
- 5.) **Model 159 Y-Strainer**. The strainer protects the pilot system from solid contaminants in the line fluid.
- 6.) **Model 155 Visual Indicator**, enables user to determine valves' operating position.

SCHEMATIC

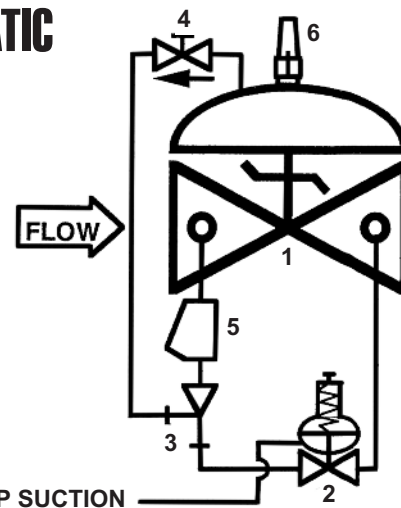

RECOMMENDED INSTALLATION

Pump valve with sense line to pump suction.

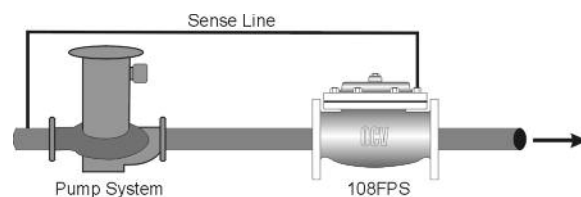

FLOW CHARACTERISTICS

where:

Q= Flow Rate in USGPM (U.S.)

or Q= Flow Rate in liters/sec (Metric)

Cv= Flow Rate in USGPM @ 1 psi pressure drop (U.S.)

or Cv= Flow Rate in liter/sec @ 1 bar pressure drop (Metric)

DP= Pressure Drop in psi (U.S.) or DP= Pressure Drop in bar (Metric)

VALVE SIZE	3" 4" 6" 8"				
	DN80	DN100	DN150	DN200	
GLOBE	US	120	200	450	760
	Metric	28.7	47.9	108	182
ANGLE	US	160	270	550	1000
	Metric	38.3	64.7	132	240

TOLL FREE 1.888.628.8258 • phone: (918)627.1942 • fax: (918)622.8916 • 7400 East 42nd Place, Tulsa, Ok 74145
 email: sales@controlvalves.com • website: www.controlvalves.com

SIZES

GLOBE/ANGLE

Flanged Ends

3" (DN80) - 8" (DN200)

SPRING RANGES (suction setting)

.34 - 2.0 bar

MAX. PRESSURE

ANSI Class 150, 17.2 bar

ANSI Class 300, 31.0 bar

ANSI Class 300 inlet x 150 outlet,

17.2 bar

TEMPERATURE RANGE (Buna-N

Elastomers)

0°C - 82°C

MATERIALS

Body/Bonnet -

Ductile Iron ASTM A536

-epoxy coated (standard)

Cast Steel ASTM A216 WCB

-epoxy coated

Stainless Steel ASTM A743 CF8M

Nickel-aluminum Bronze ASTM B148

Alloy C95800

Seat Ring -

Bronze (standard)

Stainless Steel ASTM A743CF8M

(optional)

Nickel - aluminum Bronze ASTM B148

Alloy C95800 (optional)

Stem -

Stainless Steel (standard)

Monel (optional)

Spring - Stainless Steel

Diaphragm - Nylon Reinforced Buna-N

Seat Disc - Buna-N

Pilot-

Cast Bronze (standard)

Stainless Steel ASTM A743CF8M

(optional)

Nickel - aluminum Bronze ASTM B148

Alloy C95800 (optional)

Tubing/Fittings -

Copper/brass (standard)

Stainless Steel (optional)

SPECIFICATIONS

DESIGN

The valve shall be a single-seated, line pressure operated, diaphragm actuated, pilot controlled globe or angle valve. The valve shall seal by means of a corrosion-resistant seat and resilient, rectangular seat disc. These and other parts shall be replaceable without removing the valve from the line. The stem of the main valve shall be guided top and bottom by integral bushings. Alignment of the body, bonnet and diaphragm assembly shall be by precision dowel pins. The diaphragm shall not be used as a seating surface, nor shall pistons be used as an operating means. The pilot system shall be furnished complete and installed on the main valve, and shall include an opening speed control and a Y-strainer. The valve shall be operationally and hydrostatically tested prior to shipment.

MATERIALS OF CONSTRUCTION

The main valve body and bonnet shall be ductile iron per ASTM A536, Grade 65-45-12 (or other materials refer to MATERIALS). All internal ferrous surfaces shall be coated with 4 mils of epoxy. External surfaces shall be coated with 4 mils of epoxy followed by a coat of enamel paint. The main valve seat ring shall be bronze (or other materials refer to MATERIALS). Elastomers (diaphragms, resilient seats, and O-rings) shall be Buna-N. Control pilot shall be bronze (or other materials refer to MATERIALS). The opening speed control shall be brass/stainless steel and control line tubing shall be copper (or other materials refer to MATERIALS).

OPERATING CONDITIONS

The fire pump suction control valves shall be suitable for sustaining suction pressures of .34 - 2.0 bar.

ACCEPTABLE PRODUCTS

The fire pump suction pressure control valve shall be a Model 108FPS, Factory Mutual Approved, <globe pattern, angle pattern>, with <150# flanged, 300# flanged> end connections, as manufactured by OCV Control Valves, Tulsa, OK, USA.

U.S. DIMENSIONS - INCHES

DIM	END CONN.	3	4	6	8
A	150# FLGD	12	15	17 3/4	25 3/8
	300# FLGD	12 3/4	15 5/8	18 5/8	26 3/8
B	150# FLGD	3 3/4	4 1/2	5 1/2	6 3/4
	300# FLGD	4 1/8	5	6 1/4	7 1/2
C	150# FLGD	6	7 1/2	10	12 11/16
ANGLE	300# FLGD	6 3/8	7 13/16	10 1/2	13 3/16
D	150# FLGD	4	5 1/2	6	8
ANGLE	300# FLGD	4 3/8	5 13/16	6 1/2	8 1/2
E	ALL	6 1/2	8	10	11 7/8
F	ALL	3 7/8	3 7/8	3 7/8	6 3/8
H	ALL	11	12	13	14

METRIC DIMENSIONS - M.M.

DIM	END CONN.	DN80	DN100	DN150	DN200
A	150# FLGD	305	381	451	645
	300# FLGD	324	397	473	670
B	150# FLGD	95	114	140	171
	300# FLGD	105	127	159	191
C	150# FLGD	152	191	254	322
ANGLE	300# FLGD	162	198	267	335
D	150# FLGD	102	140	152	203
ANGLE	300# FLGD	111	148	165	216
E	ALL	165	203	254	302
F	ALL	98	98	98	162
H	ALL	279	305	330	356

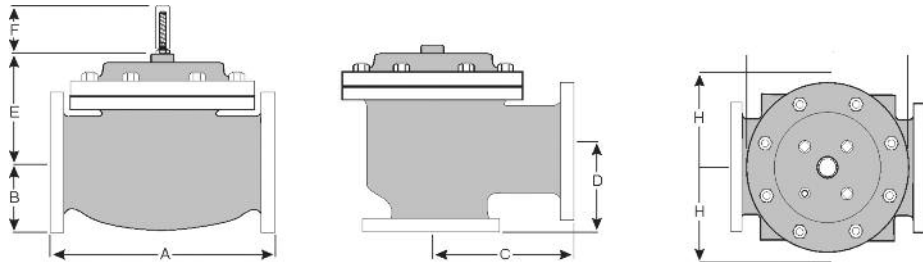

QUALITY SYSTEM
REGISTERED TO
ISO 9001

For maximum efficiency, the OCV control valve should be mounted in a piping system so that the valve bonnet (cover) is in the top position. Other positions are acceptable but may not allow the valve to function to its fullest and safest potential. In particular, please consult the factory before installing 8" (DN200) and larger valves, or any valves with a limit switch, in positions other than described. Space should be taken into consideration when mounting valves and their pilot systems.

A routine inspection & maintenance program should be established and conducted yearly by a qualified technician. Consult our factory @ **1-888-628-8258** for parts and service.

How to order your valve

When Ordering please provide:

Series Number - Valve size - Globe or Angle -

Pressure Class - Flanged - Trim Material -

Adjustment Range - Pilot Options - Special

needs / or Installation Requirements

Represented by:

TOLL FREE 1.888.628.8258 • phone: (918)627.1942 • fax: (918)622.8916 • 7400 East 42nd Place, Tulsa, Oklahoma 74145
email: sales@controlvalves.com • website: www.controlvalves.com