

Model 108-3 ▲

The Model 108-3 has a wide range of applications: anywhere a system must be protected from pressures that are too high (relief) or too low (sustaining) and reverse flow must be prevented.

Typical examples include:

- ▶ Pump systems
- ▶ Fuel distribution systems

SERIES FEATURES

- ▶ Pressure Sustaining: Prevents inlet pressure from dropping below a predetermined minimum
- ▶ Automatic closure on pressure reversal
- ▶ Operates over a wide flow range
- ▶ Set pressure is adjustable with single screw
- ▶ Quick opening and adjustable closing speed
- ▶ Can be maintained without removal from the line
- ▶ Factory tested and can be pre-set to your requirements

OPERATION

The normally closed, spring-loaded pilot, sensing upstream pressure, responds to changes in pressure and causes the main valve to do the same. The net result is a constant modulating action of the pilot and main valve to hold the upstream pressure constant. The pilot system is equipped with a closing speed control that fines tunes the valve response to the system variables.

If downstream pressure becomes greater than upstream pressure, the valve will close to prevent reverse flow.

COMPONENTS

The Model 108-3 consists of the following components, arranged as shown on the schematic diagram:

- 1.) Model 65 Basic Valve
- 2.) Model 1330 Pressure Relief Pilot
- 3.) Model 126 Ejector
- 4.) Model 141-3 Flow Control Valve (closing speed control)
- 5.) Model 141-1 Check Valve
- 6.) Model 123 Inline Strainer
- 7.) Model 155L Visual Indicator (optional)

SCHEMATIC

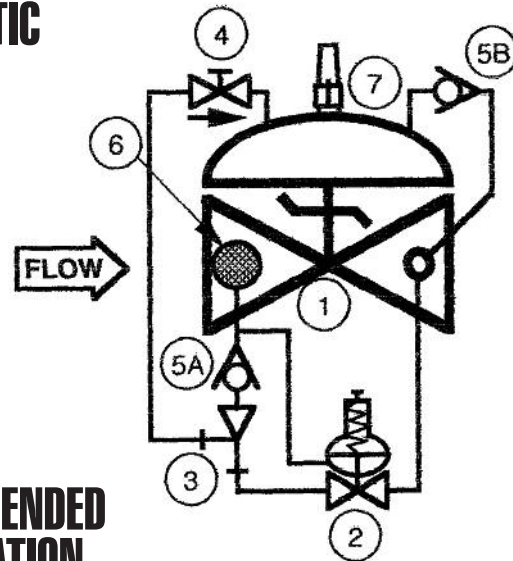

RECOMMENDED INSTALLATION

- ▶ Install the valve with adequate space above and around the valve to facilitate servicing. Refer to the Dimension Table.
- ▶ Valve should be installed with the bonnet (cover) at the top, particularly 8" and larger valves, and any valve with a limit switch.
- ▶ Shut-off valves should be installed upstream and downstream of the control valve. These are used to isolate the valve during start-up and maintenance.

SIZING

Pressure sustaining valves should be limited to a maximum velocity of 25 ft/sec. Definitive sizing information can be found in the OCV Catalog, Series 108 section and Engineering section Performance Charts. Consult factory for assistance or visit our site, www.controlvalves.com, for our fueling spec program, ValveMaster Fuels.

MAX. PRESSURE

END CONNECTIONS	DUCTILE IRON	STEEL/STN STL	ALUMINUM
Threaded	640 psi	640 psi	285 psi
Grooved	300 psi	300 psi	200 psi
150# Flanged	250 psi	285 psi	285 psi
300# Flanged	640 psi	740 psi	---

SIZE	1 1/4", 1 1/2"	2"	2 1/2"	3"	4"	6"	8"	10"	12"	14"	16"	24"
FLOW@25FT/SEC GPM	115-160	260	375	575	1000	2250	3900	6125	8750	10600	13750	31250

TOLL FREE 1.888.628.8258 ● phone: (918)627.1942 ● fax: (918)622.8916 ● 7400 East 42nd Place, Tulsa, OK 74145
 email: sales@controlvalves.com ● website: www.controlvalves.com

Model 108-3 (Fueling Service)



SIZES

GLOBE/ANGLE

Screwed Ends: 1 1/4" - 3"
 Grooved Ends: 1 1/2" - 6"
 Flanged Ends: 1 1/4" - 24" (globe);
 1 1/4" - 16" (angle)

TEMPERATURE RANGE

(Valve Elastomers)

Buna-N -40° F - 180°F

Viton 0° F - 400°F

SPRING RANGES (inlet setting)

5-30 psi, 20-80 psi, 65-180 psi,
 100-300 psi

MATERIALS

Consult factory for others.

Body/Bonnet: Ductile Iron (epoxy coated),
 Carbon Steel (epoxy coated), Stainless Steel,
 Aluminum

Seat Ring: Stainless Steel, Bronze

Stem: Stainless Steel, Monel

Spring: Stainless Steel

Diaphragm: Buna-N, Viton,
 (Nylon reinforced)

Seat Disc: Buna-N, Viton

Pilot: Stainless Steel, Bronze

Other pilot system components: Stainless
 Steel, Bronze/Brass

Tubing & Fittings:

Stainless Steel, Copper/Brass

SPECIFICATIONS (Typical Fuel Application)

The back pressure control valve shall function to prevent the upstream pressure from falling below a predetermined minimum while closing to prevent reverse flow.

DESIGN

The back pressure control valve shall be a single-seated, line pressure operated, diaphragm actuated, pilot controlled globe valve. The valve shall seal by means of a corrosion-resistant seat and a resilient, rectangular seat disc. These, and other parts, shall be replaceable without removing the valve from the line. The stem of the main valve shall be guided top and bottom by integral bushings. Alignment of the body, bonnet and diaphragm assembly shall be by precision dowel pins. The diaphragm shall not be used as a seating surface, nor shall the pistons be used as an operating means. The pilot system shall be furnished complete, installed on the main valve and include a needle valve, inline strainer and solenoid valve. The back pressure control valve shall be operationally and hydrostatically tested prior to shipment.

MATERIALS OF CONSTRUCTION

The main valve body and bonnet shall be ductile iron per ASTM A536, Grade 65-45-12. All ferrous surfaces shall be coated with 4 mils of epoxy. The main valve seat ring shall be CF8M stainless steel. Elastomers (diaphragms, resilient seats and O-rings) shall be Buna-N. The control pilot, needle valve and control line tubing shall also be Stainless Steel.

OPERATING CONDITIONS

The back pressure control valve shall be suitable for controlling the inlet pressure at <X> psi and flow rates ranging from <X to X> gpm.

ACCEPTABLE PRODUCTS

The back pressure control valve shall be a <size> Model 108-3, <globe pattern, angle pattern>, with <150# flanged, 300# flanged, threaded, grooved> end connections, as manufactured by OCV Control Valves, Tulsa, Oklahoma, USA.

U.S. DIMENSIONS - INCHES

DIM	END CONN.	1 1/4-1 1/2	2	2 1/2	3	4	6	8	10	12	14	16	24
A	SCREWED	8 3/4	9 7/8	10 1/2	13	--	--	--	--	--	--	--	--
	GROOVED	8 3/4	9 7/8	10 1/2	13	15 1/4	20	--	--	--	--	--	--
	150# FLGD	8 1/2	9 3/8	10 1/2	12	15	17 3/4	25 3/8	29 3/4	34	39	40 3/8	62
	300# FLGD	8 3/4	9 7/8	11 1/8	12 3/4	15 5/8	18 5/8	26 3/8	31 1/8	35 1/2	40 1/2	42	63 3/4
C ANGLE	SCREWED	4 3/8	4 3/4	6	6 1/2	--	--	--	--	--	--	--	--
	GROOVED	4 3/8*	4 3/4	6	6 1/2	7 5/8	--	--	--	--	--	--	--
	150# FLGD	4 1/4	4 3/4	6	6	7 1/2	10	12 11/16	14 7/8	17	--	20 13/16	--
	300# FLGD	4 3/8	5	6 3/8	6 3/8	7 13/16	10 1/2	13 3/16	15 9/16	17 3/4	--	21 5/8	--
D ANGLE	SCREWED	3 1/8	3 7/8	4	4 1/2	--	--	--	--	--	--	--	--
	GROOVED	3 1/8*	3 7/8	4	4 1/2	5 5/8	--	--	--	--	--	--	--
	150# FLGD	3	3 7/8	4	4	5 1/2	6	8	11 3/8	11	--	15 11/16	--
E	ALL	6	6	7	6 1/2	8	10	11 7/8	15 3/8	17	18	19	27
	F (OPT)	ALL	3 7/8	3 7/8	3 7/8	3 7/8	3 7/8	3 7/8	6 3/8	6 3/8	6 3/8	6 3/8	8
H	ALL	10	11	11	11	12	13	14	17	18	20	20	28 1/2

*GROOVED END NOT AVAILABLE IN 1 1/4"

For maximum efficiency, the OCV control valve should be mounted in a piping system so that the valve bonnet (cover) is in the top position. Other positions are acceptable but may not allow the valve to function to its fullest and safest potential. In particular, please consult the factory before installing 8" and larger valves, or any valves with a limit switch, in positions other than described. Space should be taken into consideration when mounting valves and their pilot systems.

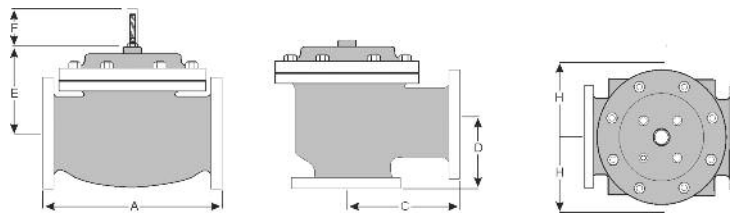

QUALITY SYSTEM
 REGISTERED TO
 ISO 9001

A routine inspection & maintenance program should be established and conducted yearly by a qualified technician. Consult our factory @ 1-888-628-8258 for parts and service.

How to order your Model 108-3 valve

When ordering please provide:

Fluid to be controlled - Model Number - Size -
 Globe or Angle - End Connection - Body Material -
 Trim Material - Elastomer Material - Pressure
 Setting or Spring Range - - Special Requirements /
 Installation Requirements

Represented by:

TOLL FREE 1.888.628.8258 • phone: (918)627.1942 • fax: (918)622.8916 • 7400 East 42nd Place, Tulsa, Oklahoma 74145
 email: sales@controlvalves.com • website: www.controlvalves.com