



▲ Model 126

The Model 126 is designed to be used on deep well pumps where the pump design permits starting against an open valve.

## SERIES FEATURES

- ▶ Eliminates surges associated with starting and stopping the pump
- ▶ Eliminates air and debris from the pump column
- ▶ Operates in conjunction with pump check valve to smoothly transition flow to and from main line
- ▶ Pump starts against an open valve that then gradually closes at a controlled rate
- ▶ Valve gradually opens at a controlled rate while pump continues to run
- ▶ Pump stops when valve is fully open
- ▶ Dual chamber design allows valve to be fully open when pump is off
- ▶ Separate adjustable opening and closing speeds
- ▶ Can be maintained without removal from the line
- ▶ Factory tested

## OPERATION

The 126 is controlled by an electrical 4-way solenoid which is energized at pump start. This pressurizes the upper diaphragm chamber while simultaneously venting the lower chamber, causing the valve to close at an adjustable, controlled rate, smoothly transitioning flow into the system through the pump check valve. At shut-down, the solenoid is de-energized, pressurizing the lower diaphragm chamber while simultaneously venting the upper chamber, causing the valve to open at an adjustable controlled rate while the pump (held on by the valve limit switch) continues to run. When the valve is fully open, the pump is finally shut off.

## COMPONENTS

The Model 126 consists of the following components, arranged as shown on the schematic diagram:

- 1.) Model 66 Basic Power-Actuated Valve
- 2.) Model 453 Four-way Solenoid Pilot
- 3.) Model 141-3 Flow Control Valves
- 4.) Model 141-1 Check Valve
- 5.) Model 159 Y-Strainers
- Protects pilot system from dirt/debris
- 6.) Model 141-4 Isolation Ball Valves
- 7.) Model 31 Limit Switch Assembly

## SCHEMATIC

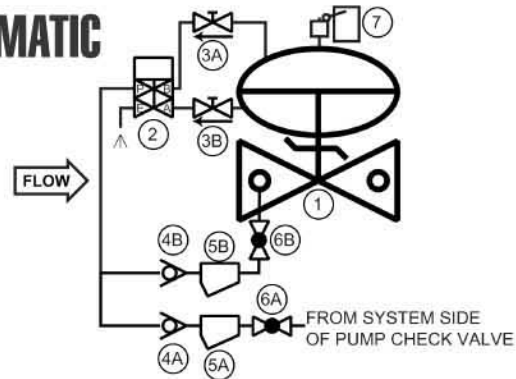

## RECOMMENDED INSTALLATION

OCV recommends that all Model 126 valves are installed horizontally, bonnet "up." The Model 126 exhausts its diaphragm chamber to atmosphere, the volume varying according to valve size, as shown below. Provisions should be made drain or otherwise dispose of this water.

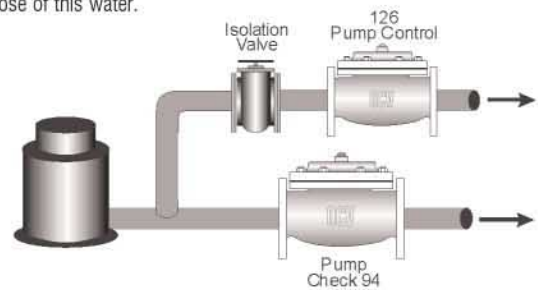

1 1/4" - 1 1/2"	0.02 gallons	8"	1.0 gallon
2"	0.05 gallons	10"	2.5 gallons
2 1/2"	0.06 gallons	12"	4.0 gallons
3"	0.1 gallons	14"	6.5 gallons
4"	0.2 gallons	16"	9.6 gallons
6"	0.6 gallons	24"	28.0 gallons

## TYPICAL WIRING DIAGRAM

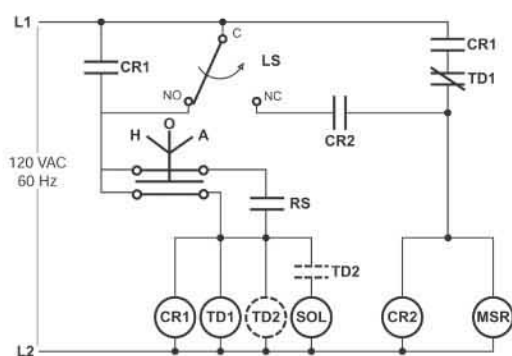

## SIZING

Definitive sizing information can be found in the OCV Catalog, Series 125 section. Consult the factory for assistance and a copy of the OCV ValveMaster Sizing program

TOLL FREE 1.888.628.8258 • phone: (918)627.1942 • fax: (918)622.8916 • 7400 East 42nd Place, Tulsa, Ok 74145  
email: sales@controlvalves.com • website: www.controlvalves.com

**Global** performance. **Personal** touch.

**Model 126 Deep Well Pump Control Valve**

## SIZES

### GLOBE/ANGLE

Screwed Ends 1 1/4" - 3"  
Grooved Ends 1 1/2" - 4"  
Flanged Ends 1 1/4" - 24" (globe);  
1 1/4" - 16" (angle)

### MAX. PRESSURE

250 psi (Limited by solenoid - for pressures up to 400 psi, consider Model 126P)

### TEMPERATURE RANGE (Valve Elastomers)

Buna-N -40° F - 180°F

Viton 0° F - 400°F

EPDM 0° F - 300°F

### MATERIALS - Consult factory for others.

**Body/Bonnet:** Ductile Iron (epoxy coated), Carbon Steel (epoxy coated), Stainless Steel, B61 Bronze, Others available (consult factory)

**Seat Ring:** Bronze B61, Stainless Steel

**Stem:** Stainless Steel, Monel

**Spring:** Stainless Steel

**Diaphragm:** Nylon Reinforced, Buna-N, Viton, EPDM

**Seat Disc:** Buna-N, Viton, EPDM

**Pilot:** Bronze, Stainless Steel

**Other pilot system components:** Bronze/Brass, All Stainless Steel

**Tubing & Fittings:** Copper/Brass, Stainless Steel

**Solenoid:** 4-way type

Enclosure: **Weatherproof NEMA 4X**; Explosion Proof NEMA 4X, 6P, 7, 9

**Body:** Brass

**Volages:** 24, 120, 240, 480 VAC; 12, 24 VDC

**Limit Switch:**

Enclosure: Weatherproof NEMA 4; Explosion Proof NEMA 7,9

**Contacts:** SPDT (std) / DPDT (opt)

## SPECIFICATIONS (Typical Water Application)

The pump control valve shall function to eliminate the surges from starting and stopping the pump by working in conjunction with the pump check valve. It shall also function to eliminate air and debris from the pump column. The valve shall be open when the pump is started. It shall then close slowly, gradually introducing flow into the line. When the pump is signaled to stop, the pump control valve shall slowly open while the pump continues to run. As the valve approaches the full open position, the valve stem shall trip a limit switch mounted on the valve. The limit switch shall then shut down the pump. Opening and closing speeds shall be independently adjustable.

### DESIGN

The valve shall be a single-seated, line pressure operated, diaphragm actuated, pilot controlled, dual chambered globe valve. The valve shall seal by means of a corrosion-resistant seat and a resilient, rectangular seat disc. These, and other parts, shall be replaceable without removing the valve from the line. The stem of the main valve shall be guided top and bottom by integral bushings. Alignment of the body, bonnet and diaphragm assembly shall be by precision dowel pins. The diaphragm shall not be used as a seating surface, nor shall the pistons be used as an operating means. The pilot system shall be furnished complete and installed on the main valve. It shall include separate opening and closing speed controls, a Y-strainer and isolation ball valves. The valve shall be operationally and hydrostatically tested prior to shipment.

### MATERIALS OF CONSTRUCTION

The main valve body and bonnet shall be ductile iron per ASTM A536, Grade 65-45-12. All ferrous surfaces shall be coated with 4 mils of epoxy. The main valve seat ring shall be bronze per ASTM B61. Elastomers (diaphragms, resilient seats and O-rings) shall be Buna-N. Control pilots shall be ASTM B61 bronze. The speed controls and isolation ball valves shall be brass and control line tubing shall be copper. The solenoid shall have a brass body and the coil shall be suitable for operation on 110-120 volts AC, 50-60 Hz. The limit switch shall be equipped with SPDT contacts rated at 15 amps at 125-480 VAC. Limit switch and solenoid enclosures shall be weatherproof per NEMA 4.

### OPERATING CONDITIONS

The pump control valve shall be suitable for a flow of <X> gpm and a maximum pump shutoff pressure of <X> psig.

### ACCEPTABLE PRODUCTS

The pump control valve shall be a <size> Model 126, <globe pattern, angle pattern>, with <150# flanged, 300# flanged, threaded, grooved> end connections, as manufactured by OCV Control Valves, Tulsa, Oklahoma, USA.

U.S. DIMENSIONS - INCHES

DIM	END CONN.	1 1/4-1 1/2	2	2 1/2	3	4	6	8	10	12	14	16	24
A	SCREWED	8 3/4	9 7/8	10 1/2	13	--	--	--	--	--	--	--	--
	GROOVED	8 3/4	9 7/8	10 1/2	13	15 1/4	20	--	--	--	--	--	--
	150# FLGD	8 1/2	9 3/8	10 1/2	12	15	17 3/4	25 3/8	29 3/4	34	39	40 3/8	62
	300# FLGD	8 3/4	9 7/8	11 1/8	12 3/4	15 5/8	18 5/8	26 3/8	31 1/8	35 1/2	40 1/2	42	63 3/4
C	SCREWED	4 3/8	4 3/4	6	6 1/2	--	--	--	--	--	--	--	--
	GROOVED	4 3/8*	4 3/4	6	6 1/2	7 5/8	--	--	--	--	--	--	--
	150# FLGD	4 1/4	4 3/4	6	6	7 1/2	10	12 11/16	14 7/8	17	--	20 13/16	--
	300# FLGD	4 3/8	5	6 3/8	6 3/8	7 13/16	10 1/2	13 3/16	15 9/16	17 3/4	--	21 5/8	--
D	SCREWED	3 1/8	3 7/8	4	4 1/2	--	--	--	--	--	--	--	--
	GROOVED	3 1/8*	3 7/8	4	4 1/2	5 5/8	--	--	--	--	--	--	--
	150# FLGD	3	3 7/8	4	4	5 1/2	6	8	11 3/8	11	--	15 11/16	--
E	300# FLGD	3 1/8	4 1/8	4 3/8	4 3/8	5 13/16	6 1/2	8 1/2	12 1/16	11 3/4	--	16 1/2	--
	ALL	6	6	7	6 1/2	8	10	11 7/8	15 3/8	17	18	19	27
F	ALL	3 7/8	3 7/8	3 7/8	3 7/8	3 7/8	3 7/8	6 3/8	6 3/8	6 3/8	6 3/8	6 3/8	8
H	ALL	10	11	11	11	12	13	14	17	18	20	20	28 1/2

\*GROOVED END NOT AVAILABLE IN 1 1/4"

For maximum efficiency, the OCV control valve should be mounted in a piping system so that the valve bonnet (cover) is in the top position. Other positions are acceptable but may not allow the valve to function to its fullest and safest potential. In particular, please consult the factory before installing 8" and larger valves, or any valves with a limit switch, in positions other than described. Space should be taken into consideration when mounting valves and their pilot systems.

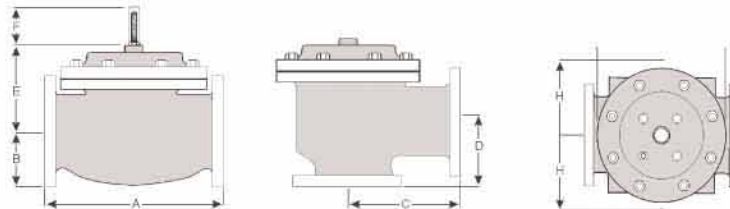

QUALITY SYSTEM REGISTERED TO ISO 9001

A routine inspection & maintenance program should be established and conducted yearly by a qualified technician. Consult our factory @ 1-888-628-8258 for parts and service.

### How to order your Model 126 valve

When Ordering please provide:

Fluid to be controlled -Model Number -Size  
Globe or Angle -End Connection -Body Material  
Trim Material -Solenoid Voltage -Solenoid enclosure  
Weatherproof or Explosion Proof -Special Requirements / Installation Requirements

Represented by:

TOLL FREE 1.888.628.8258 • phone: (918)627.1942 • fax: (918)622.8916 • 7400 East 42nd Place, Tulsa, Oklahoma 74145  
email: sales@controlvalves.com • website: www.controlvalves.com