



▲ High Level Shut-Off Valve  
Sizes: 6" - 24"

The Model 8104 is applicable anywhere it is necessary to automatically control the high level in storage tanks where the float pilot can be mounted inside the tank.

## SERIES FEATURES

- ▶ Allows tank filling and shuts off on high level
- ▶ Remote-mounted float pilot (inside tank)
- ▶ Two field-installed lines between valve and float pilot
- ▶ Can be maintained without removal from the line
- ▶ Adjustable response speed
- ▶ Manual tester available on float pilot
- ▶ Factory tested and can be pre-set to your requirements

## OPERATION

The Model 8104 is designed for tank fill only. A rotary, float-activated pilot controls the position of the normally closed relay pilot which in turn controls the position of the main valve. With the float in the full down position, the relay pilot is wide open, along with the main valve. When fluid level raises the float to the high level position, flow is blocked, closing the relay pilot and the main valve.

## COMPONENTS

The Model 8104 consists of the following components, arranged as shown on the schematic diagram:

- 1.) Model 65 Basic Control Valve (fail closed)
- 2.) Two-Way Float Pilot
- 3.) Differential Control Pilot
- 4.) Ejector
- 5.) Needle Valve
- 6.) Inline Strainer
- 7.) Ball Valve
- 8.) Visual Indicator

## SCHEMATIC

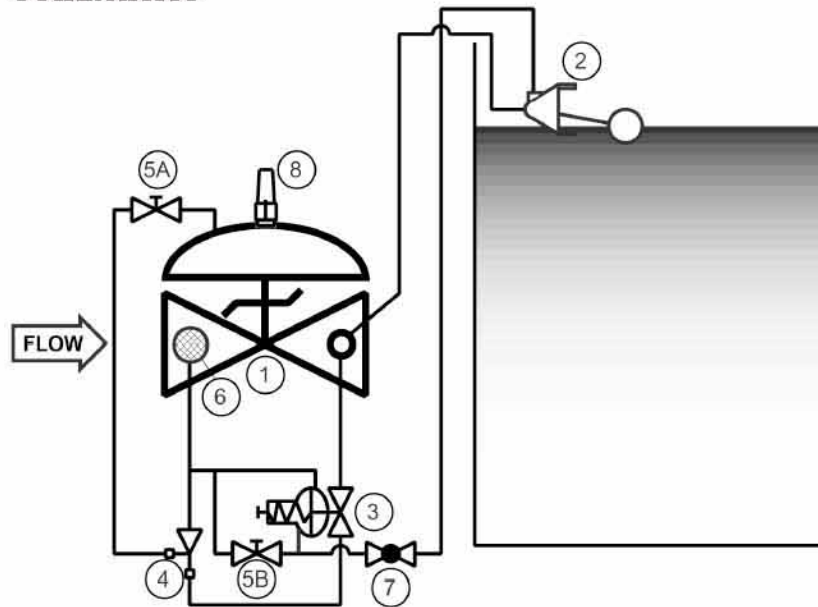

## RECOMMENDED INSTALLATION

- ▶ Install the valve with adequate space above and around the valve to facilitate servicing. Refer to the Dimension Table.
- ▶ Shut-off valves should be installed upstream and downstream of the control valve. These are used to isolate the valve during start-up and maintenance.
- ▶ Install the float pilot inside the tank at the required high level and connect to main valve as shown on the diagram (1/2" O.D. tubing recommended).

## SIZING

While most Model 8104 Float Valves are line size, there are two factors to check.

First, to avoid using a valve that is too small, flow rate should be limited to a maximum of 25 ft/sec velocity. Second, using a valve that is too large can result in the loss of inlet pressure, which is needed to close the valve on high level. Definitive sizing information can be found in the OCV Catalog, Series 8100 Section, Engineering Section Performance Charts, or [www.controlvalves.com](http://www.controlvalves.com). Consult the factory for assistance.

SIZE	6"	8"	10"	12"	14"	16"	24"
MIN. FLOW, GPM	450	780	1225	1750	2100	2750	6250
MAX. FLOW, GPM	2250	3900	6150	8700	10500	13800	31300

TOLL FREE 1.888.628.8258 • phone: (918)627.1942 • fax: (918)622.8916 • 7400 East 42nd Place, Tulsa, OK 74145  
email: [sales@controlvalves.com](mailto:sales@controlvalves.com) • website: [www.controlvalves.com](http://www.controlvalves.com)

## SIZES

Globe or Angle

Grooved Ends: 6"

Flanged Ends:

(globe) 6" - 24"

(angle) 6" - 16"

For smaller valve sizes, refer to Model 8101.

## MAX. WORKING PRESSURE

Maximum pressure on all materials and end connections is limited to 250psi by the float pilot.

## TEMPERATURE RANGE

Buna-N Elastomers:

40° F - 180° F

Viton: 0° F - 400° F

**MATERIALS** (Consult factory for others)

### Body/Bonnet:

-Ductile Iron (epoxy coated), Carbon Steel (epoxy coated), Stainless Steel, Aluminum

**Seat Ring:** Stainless Steel, Bronze

**Stem:** Stainless Steel, Monel

**Spring:** Stainless Steel

**Diaphragm:** Buna-N, Viton (Nylon reinforced)

**Seat Disc:** Buna-N, Viton

**Pilot:** Stainless Steel, Bronze

**Other pilot system components:** Stainless Steel, Bronze/Brass

**Tubing & Fittings:** Stainless Steel, Copper/Brass

## SPECIFICATIONS (Typical Fuel Application)

The high level shut-off valve shall be installed on the inlet line to the tank and shall close when the high level is reached. The high level shut-off valve shall include a simple, two-way, non-adjustable float pilot to be installed in the tank at the desired tank level and be connected to the main valve by two, customer-installed sense lines.

### DESIGN

The high level shut-off valve shall be a single-seated, line pressure operated, diaphragm actuated, pilot controlled globe valve. The valve shall seal by means of a corrosion-resistant seat and a resilient, rectangular seat disc. These, and other parts, shall be replaceable without removing the valve from the line. The stem of the main valve shall be guided top and bottom by integral bushings. Alignment of the body, bonnet and diaphragm assembly shall be by precision dowel pins. The diaphragm shall not be used as a seating surface, nor shall the pistons be used as an operating means. The pilot system shall include a relay pilot, a speed control, in-line strainer and an isolation ball valve. The float pilot shall be furnished separately for remote mounting in the tank. The high level shut-off valve shall be operationally and hydrostatically tested prior to shipment.

### MATERIALS OF CONSTRUCTION

The main valve body and bonnet shall be ductile iron per ASTM A536, Grade 65-45-12. All ferrous surfaces shall be coated with 4 mils of epoxy. The main valve seat ring shall be CF8M stainless steel. Elastomers (diaphragms, resilient seats and O-rings) shall be Buna-N. The float pilot shall be stainless steel as shall the 5" spherical float, relay pilot, pilot system accessories and control line tubing.

### OPERATING CONDITIONS

The high level shut-off valve shall be suitable for a maximum flow rate of <X> gpm at inlet pressures ranging from <X> to X psi.

### ACCEPTABLE PRODUCTS

The high level shut-off valve shall be a <size> Model 8104, <globe pattern, angle pattern>, with <150# flanged, 300# flanged, grooved> end connections, as manufactured by OCV Control Valves, Tulsa, Oklahoma, USA.

U.S. DIMENSIONS - INCHES

DIM	END CONN.	6	8	10	12	14	16	24
A	SCREWED	--	--	--	--	--	--	--
	GROOVED	20	--	--	--	--	--	--
	150# FLGD	17 3/4	25 3/8	29 3/4	34	39	40 3/8	62
	300# FLGD	18 5/8	26 3/8	31 1/8	35 1/2	40 1/2	42	63 3/4
C	SCREWED	--	--	--	--	--	--	--
	GROOVED	--	--	--	--	--	--	--
	150# FLGD	10	12 11/16	14 7/8	17	--	20 13/16	--
ANGLE	300# FLGD	10 1/2	13 3/16	15 9/16	17 3/4	--	21 5/8	--
D	SCREWED	--	--	--	--	--	--	--
	GROOVED	--	--	--	--	--	--	--
	150# FLGD	6	8	11 3/8	11	--	15 11/16	--
ANGLE	300# FLGD	6 1/2	8 1/2	12 1/16	11 3/4	--	16 1/2	--
E	ALL	10	11 7/8	15 3/8	17	18	19	27
H	ALL	13	14	17	18	20	20	28 1/2

\*GROOVED END NOT AVAILABLE IN 1 1/4"

OCV high level shut-off valves can be mounted in the horizontal or vertical position, however 8" and larger valves are best suited to be mounted horizontally. Space should be taken into consideration when mounting valves and their pilot systems.

A routine inspection & maintenance program should be established and conducted yearly by a qualified technician. Consult our factory @ 1-888-628-8258 for parts and service.

When ordering your 8104 valve, please provide:

Fluid to be controlled - Model Number - Size - Globe or Angle End Connection - Body Material Trim Material - Pilot Options Special Requirements / Installation Requirements

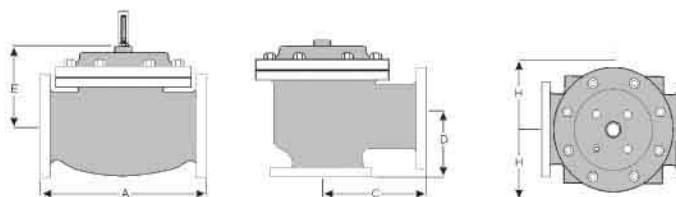

QUALITY SYSTEM REGISTERED TO ISO 9001

Represented by:

TOLL FREE 1.888.628.8258 • phone: (918)627.1942 • fax: (918)622.8916 • 7400 East 42nd Place, Tulsa, Oklahoma 74145  
email: sales@controlvalves.com • website: www.controlvalves.com