



▲ Model 66TS



The Model 66TS Tank Safety Valve is designed to automatically isolate a fuel storage tank from its loading terminal or product transfer point. Hydraulically linked to the delivery pump, the valve is open only when the pump runs and is effectively producing pressure. The valve will automatically close when the pump is off, fails to produce pressure, or in the event of a line rupture.

SERIES FEATURES

- ▶ Totally hydraulic operation; no electrical connections
- ▶ Dual chamber, full open, low pressure drop design
- ▶ Thermal relief of excess downstream pressure
- ▶ Provides anti-siphon protection
- ▶ Capable of manual operation
- ▶ Can be maintained without removal from the line
- ▶ Valve position indicator standard
- ▶ Factory tested

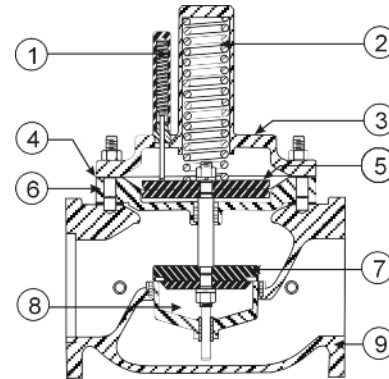

OPERATION

The 66TS is built on a dual diaphragm chamber valve design. It is opened and closed by pressure applied to either side of the diaphragm. The lower chamber receives pressure from pump discharge and acts to open the valve while loss of this pressure allows the valve spring to close the valve.

Opening Cycle- When the pump discharge pressure reaches 0.3 bar over tank head, the valve begins to open. It is fully open when pump discharge is 1 bar over tank head.

Closing Cycle- Valve closing will start when pump discharge pressure drops for any reason to tank head. This may be due to normal pump shut down, pump failure or line rupture.

Manual Opening- The valve is equipped with an Schrader air valve to enable connection of a pressure source (hand pump, low pressure air bottle, etc.) to open the valve.

Thermal Relief- Pressure buildup of 0.5 - 0.6 bar (above tank head) in the downstream piping will automatically be relieved back through the valve to the tank.

COMPONENTS

The Model 66TS consists of the following components, arranged as shown on the schematic diagram:

- 1.) Valve Position Indicator
- 2.) Valve Closing Spring
- 3.) Bonnet
- 4.) Diaphragm
- 5.) Diaphragm Plate
- 6.) Intermediate Plate
- 7.) Seat Disc
- 8.) Seat Assembly
- 9.) Valve Body

CROSS-SECTION DRAWING

RECOMMENDED INSTALLATION

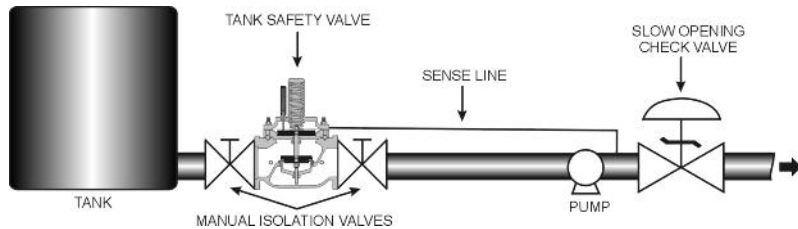

- ▶ Install the proper size sense line from the pump discharge to the valve connection. Based on a valve-to-pump distance of 180 meters, the following schedule 40 pipe sizes are recommended

VALVE SIZE:	DN50-80	DN100-150	DN200	DN250	DN300
SENSE LINE SIZE:	3/8"	3/4"	1"	1 1/4"	1 1/2"

- ▶ Sense line connection at 66TS should have a ball type or positive shut off type valve installed (to facilitate manual opening).
- ▶ To prevent pump cavitation on start-up, pump discharge check valve should be of the slow-opening type to ensure adequate pressure for initial opening of the tank safety valve.
- ▶ Install the valve with adequate space above and around the valve to facilitate servicing. Refer to the Dimension Table.
- ▶ Valve should be installed with the bonnet (cover) at the top.

SIZING

The size of the 66TS is typically the same as the pump suction line. However, the velocity through the valve should never exceed 6 meters/second, as shown below. Valve pressure drop may be calculated using the Cv values shown. **NOTE:** Cv=Flow in M³/HR at 1 bar pressure drop.

MAX. PRESSURE

END CONNECTIONS	DUCTILE IRON	STEEL WCB	STEEL LCB	STN. STEEL CF8M
Threaded	44.1 bar	44.1 bar	44.1 bar	44.1 bar
Grooved	20.7 bar	20.7 bar	20.7 bar	20.7 bar
150# Flanged	17.2 bar	19.7 bar	18.4 bar	19.0 bar
300# Flanged	44.1 bar	51.0 bar	48.0 bar	49.6 bar

SIZE, DN	50	80	100	150	200	250	300	400
MAX. FLOW, M ³ /HR	45	105	182	409	681	954	1363	2180
Valve Cv	41	104	173	389	649	1080	1695	2465

phone: (918)627.1942 • fax: (918)622.8916 • 7400 East 42nd Place, Tulsa, OK 74145
 email: sales@controlvalves.com • website: www.controlvalves.com

SIZES

GLOBE/ANGLE

Screwed Ends: 2" - 3" (DN50 thru DN80)

Grooved Ends: 2" - 6" (DN50 thru DN150)

Flanged Ends:

2" - 16" (DN50 thru DN400) (globe);

2" - 16" (DN50 thru DN400) (angle)

TEMPERATURE RANGE

(Valve Elastomers)

Buna-N -40°C - 82°C

Viton -17°C - 204°C

MATERIALS

Consult factory for others.

Body/Bonnet: Ductile Iron

(epoxy coated), Carbon Steel (epoxy coated), Stainless Steel

Seat Ring: Stainless Steel, Bronze

Stem: Stainless Steel, Monel

Spring: Stainless Steel

Diaphragm: Buna-N, Viton,

(Nylon reinforced)

Seat Disc: Buna-N, Viton

Tubing & Fittings: Stainless Steel

SPECIFICATIONS (Typical Fuel Application)

The tank safety valve shall operate by means of hydraulic pressure from the transfer pump discharge. The valve shall open on positive pressure and close on loss of pressure. It shall be equipped to relieve downstream to upstream in the event of thermal buildup. It shall be equipped with a manual opening feature and valve position indicator.

DESIGN

The tank safety valve shall be a single-seated, dual chamber, diaphragm actuated globe valve. The valve shall seal by means of a corrosion-resistant seat and a resilient, rectangular seat disc. These, and other parts, shall be replaceable without removing the valve from the line. The stem of the main valve shall be guided top and bottom by integral bushings. Alignment of the body, lower chamber and diaphragm assembly shall be by precision dowel pins. The diaphragm shall not be used as a seating surface, nor shall the pistons be used as an operating means. The tank safety valve shall be operationally and hydrostatically tested prior to shipment.

MATERIALS OF CONSTRUCTION

The main valve body and bonnet shall be ductile iron per ASTM A536, Grade 65-45-12. All ferrous surfaces shall be coated with 4 mils of epoxy. The main valve seat ring shall be CF8M stainless steel. Elastomers (diaphragms, resilient seats and O-rings) shall be Buna-N.

ACCEPTABLE PRODUCTS

The tank safety valve shall be a <size> Model 66TS, <globe pattern, angle pattern>, with <150# flanged, 300# flanged, threaded, grooved> end connections, as manufactured by OCV Control Valves, Tulsa, Oklahoma, USA.

DIM	ANSI FLANGE	DN50	DN80	DN100	DN150	DN200	DN250	DN300	DN400
A	150	238	305	381	451	645	756	864	1026
	300	251	324	397	473	670	791	902	1067
B	150	76	95	114	140	171	203	241	298
	300	83	105	127	159	191	222	260	324
C	ALL	250	273	343	445	508	584	635	813
D	ALL	86	111	149	178	267	311	356	438
E	ALL	105	130	162	219	305	356	406	489

CE Markings

Applies to fuel valves installed in the European Union in accordance with the Pressure Equipment Directive, 97/23/EC

CE-marked valves are available in LCB steel and CF8M stainless steel only

OCV is registered to the PED through Det Norske Veritas

The following valves will be CE-marked:

- 6" (DN150) and larger valves, 150# and 300# class, liquid fuel only
- 2" (DN50) thru 4" (DN100) valves, 300# class, liquid fuel
- 1 1/4" (DN32) thru 4" (DN100) valves, 300# class, LPG or Butane service
- 4" (DN100) and smaller valves in Class 150# (liquids) are furnished under SEP with no CE-mark

For maximum efficiency, the OCV control valve should be mounted in a piping system so that the valve bonnet (cover) is in the top position. Other positions are acceptable but may not allow the valve to function to its fullest and safest potential. In particular, please consult the factory before installing 8" (DN200) and larger valves, or any valves with a limit switch, in positions other than described. Space should be taken into consideration when mounting valves and their pilot systems.

A routine inspection & maintenance program should be established and conducted yearly by a qualified technician. Consult our factory @ **1-918-627-1942** for parts and service.

How to order your Model 66TS valve

When ordering please provide:

Fluid to be controlled - Model Number - Size - Globe or Angle - End

Connection - Body Material - Trim Material - Elastomers - Special

Requirements / Installation Requirements

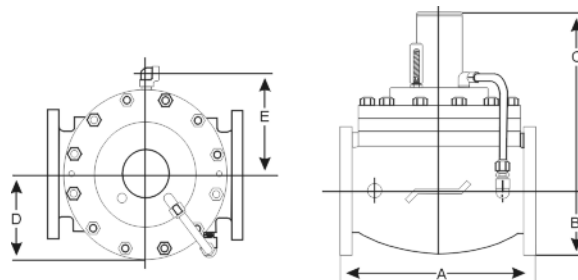

QUALITY SYSTEM
REGISTERED TO
ISO 9001

phone: (918)627.1942 • fax: (918)622.8916 • 7400 East 42nd Place, Tulsa, Oklahoma 74145

email: sales@controlvalves.com • website: www.controlvalves.com