

The OCV Basic Control Valve 65 Globe and 65 Angle is a full port engineered valve. When equipped with a variety of pilots and accessories the valve performs a wide range of automatic fluid control, making it a specified valve in municipal water, fire protection, irrigation, industrial, petroleum and aviation fueling systems.

The 65 is dependable and hard working; with a simplicity of design that ensures minimal part wear for exceptional performance and longevity. Self-contained, the valve operates automatically off line pressure.

The 65 consists of three major components: body, bonnet and diaphragm assembly.



◀ 65 Globe Flanged shown

## FEATURES / BENEFITS

- ▶ Operates automatically off line pressure.
- ▶ Heavy-duty, nylon-reinforced diaphragm isolates top chamber operating pressure from bottom chamber line pressure.
- ▶ Rectangular-shaped, soft seat seal provides drip-tight Class VI closure.
- ▶ Diaphragm assembly guided top and bottom
- ▶ Throttling seat retainer for flow and pressure stability.
- ▶ Easily maintained without removal from the line.
- ▶ Diaphragm replaced without removing internal stem assembly.
- ▶ Replaceable seat ring.
- ▶ Alignment pins assure proper reassembly after maintenance.
- ▶ Center-tapped bonnet facilitates installation of position indicator or valve-actuated switches.
- ▶ Ductile iron and steel valves are epoxy-coated inside and out, for maximum corrosion protection.
- ▶ Valves are factory tested.
- ▶ Valves are serial numbered and registered to facilitate replacement parts and factory support.

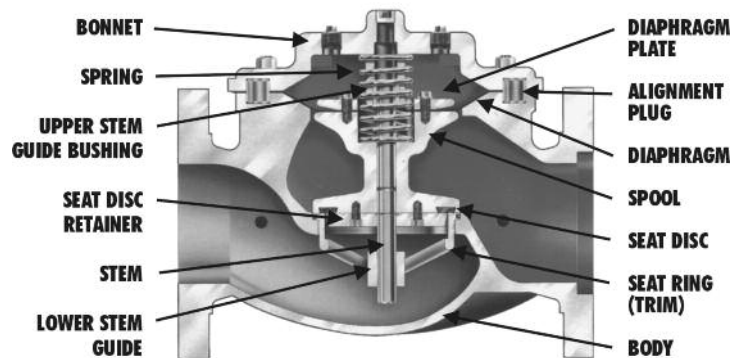

TOLL FREE 1.888.628.8258 • phone: (918)627.1942 • fax: (918)622.8916 • 7400 East 42nd Place, Tulsa, OK 74145  
 email: sales@controlvalves.com • website: www.controlvalves.com

## VALVE OPERATION

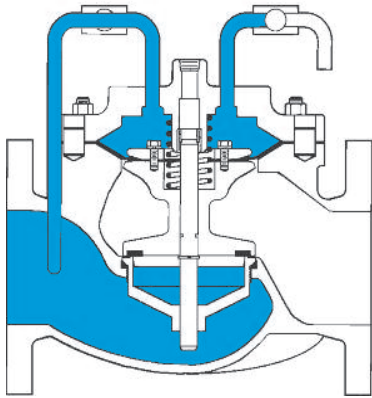

### Valve Closed

When line pressure from the valve inlet is applied to the cover chamber, pressuring the diaphragm, the valve is closed drip-tight.

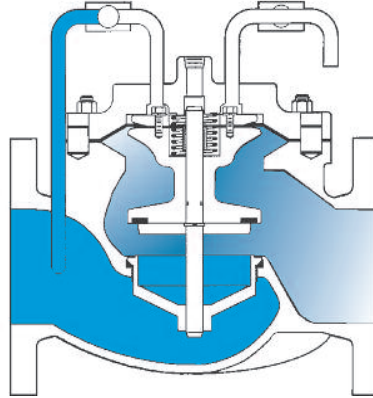

### Valve Open

When diaphragm chamber pressure is vented the valve travels to the full open position.

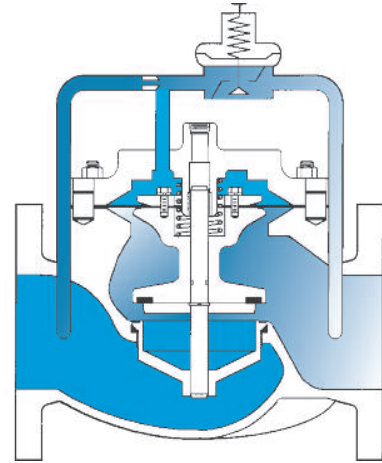

### Valve Modulating

The valve is between full open and closed. The valve's control pilot modulates the pressure in the diaphragm chamber, positioning the valve to control the desired pressure or flow. OCV pilot systems provide accurate control in a wide range of performance requirements.

## BASIC VALVE FLOW CHARACTERISTICS

VALVE SIZE	US	1 1/4"	1 1/2"	2"	2 1/2"	3"	4"	6"	8"	10"	12"	14"	16"	24"
	METRIC	DN32	DN40	DN50	DN65	DN80	DN100	DN150	DN200	DN250	DN300	DN350	DN400	DN600
GLOBE Cv	US	23	27	47	68	120	200	450	760	1250	1940	2200	2850	6900
	METRIC	5.5	6.5	11.3	16.3	28.7	47.9	108	182	299	465	527	683	1653
ANGLE Cv	US	30	35	65	87	160	270	550	1000	1600	2400	--	4000	--
	METRIC	7.2	8.4	15.6	20.8	38.3	64.7	132	240	383	575	--	958	--

where:

$$DP = sg \left( \frac{Q}{C_v} \right)^2$$

Q = Flow Rate in USGPM (U.S.) or Q = Flow Rate in liters/sec (Metric)

Cv = Flow Rate in USGPM @ 1 psi pressure drop (U.S.) or Cv = Flow Rate in liter/sec @ 1 bar pressure drop (Metric)

DP = Pressure drop in psi (U.S.) or DP = Pressure drop in bar (Metric)

sg = specific gravity of line fluid

## ABOUT YOUR VALVE

OCV Control Valves was founded more than 50 years ago with a vision and commitment to quality and reliability. From modest beginnings, the company has grown to be a global leader just a half century later. In fact, OCV Valves can be found in some capacity in nearly every country around the world from fire protection systems in Malaysia to aircraft fueling systems in Africa and from oil refineries in Russia to water supply systems in the USA and Canada. You will also find our valves in irrigation systems in Europe, South America and the Middle East.

The original foundation on which the company was built allows our team of professionals to not only provide the service required to be a worldwide supplier, but more importantly the opportunity to afford the personal touch necessary to be each of our customers' best partner. Simply stated, we take pride in all that we do.

Committed to the work they do, our employees average over 15 years of service. This wealth of knowledge allows us to provide quality engineering, expert support, exacting control and the know-how to create valves known for their long life.

Being ISO 9001 certified means we are committed to a quality assurance program. Our policy is to supply each customer with consistent quality products and ensure that the process is right every time. Our valves meet and exceed industry standards around the world. Including approvals by:



Check individual models for availability.

All valves are not created equal. OCV Control Valves proves that day in and day out. We stand behind our valves and are ready to serve your needs.

TOLL FREE 1.888.628.8258 • phone: (918)627.1942 • fax: (918)622.8916 • 7400 East 42nd Place, Tulsa, Oklahoma 74145  
email: sales@controlvalves.com • website: www.controlvalves.com

## SPECIFICATIONS

VALVE BODY & BONNET	DUCTILE IRON		CAST STEEL		CAST BRONZE		STAINLESS STEEL	
<b>Material Specifications</b>	ASTM A536 (epoxy coated)		ASTM A216/WCB (epoxy coated)				ASTM A743/CF8M	
<b>END CONNECTIONS</b>								
Flange Standard (also available in metric)	ANSI B16.42		ANSI B16.5		ANSI B16.24		ANSI B16.5	
Flange Class	150#	300#	150#	300#	150#	300#	150#	300#
Flange Face	Flat	Raised	Raised	Raised	Flat	Flat	Raised	Raised
Maximum Working Pressure	250 psi (17.2 bar)	640 psi (44.1 bar)	285 psi (19.6 bar)	740 psi (51.0 bar)	225 psi (15.5 bar)	500 psi (34.5 bar)	285 psi (19.6 bar)	740 psi (51.0 bar)
Screwed Working Pressure: ANSI B1.20.1 (B2.1) 640 psi (44.1 bar); Bronze 500 psi (34.5 bar) Grooved End Working Pressure: 300 psi (20.7 bar)								
<b>INTERNALS</b>								
Stem	STAINLESS STEEL AISI 303				OPTIONAL MONEL			
Spring	STAINLESS STEEL AISI 302							
Spool	DUCTILE IRON ASTM A536 (epoxy coated)				B-61		STN. STL. ASTM A 743/CF8M	
Seat Disc Retainer	DUCTILE IRON ASTM A536 (epoxy coated) 4" & SMALLER VALVES - STAINLESS STEEL				B-61		STAINLESS STEEL	
Diaphragm Plate	DUCTILE IRON ASTM A536 (epoxy coated)				B-61		STAINLESS STEEL	
Seat Ring (Trim)	BRONZE B61 OPTIONAL STAINLESS STEEL ASTM A743/CF8M						STN. STL. ASTM A 743/CF8M	
Upper Stem Bushing	STANDARD BRONZE ASTM B438		VALVE W/ STAINLESS STEEL SEAT RING-TEFLON				TEFLON	
Lower Stem Bushing	SEAT MATERIAL VALVES W/ STAINLESS STEEL SEAT RING-TEFLON						TEFLON	
<b>ELASTOMER PARTS (Rubber)</b>								
Diaphragm/Seat Disc/O-Rings	STANDARD - BUNA-N NYLON REINFORCED				OPTIONAL - VITON®		OPTIONAL - EPDM	
Operating Temperature	-40°F to 180°F (-40°C to 82°C)		32°F to 400°F (0°C to 204°C)		0°F to 300°F (-17°C to 149°C)			
<b>COATINGS</b>								
WIDE RANGE OF COATING PER YOUR FLUID APPLICATION. COATINGS HANDLE MUNICIPAL POTABLE WATER, SEAWATER, PETROLEUM AND REFINED PRODUCTS.								

VITON® is a registered trademark of DuPont Dow Elastomers.

### SALTWATER SERVICE VALVE MATERIALS

Cast Steel Special Coatings --Ni Aluminum Bronze ASTM B148 --Super Duplex Stainless Steel



#### Globe Flanged Sizes

1.25"	1.5"	2"	2.5"	3"	4"	6"	8"	10"	12"	14"	16"	18"*	20"*	24"
32mm	40mm	50mm	65mm	80mm	100mm	150mm	200mm	250mm	300mm	350mm	400mm	450mm*	500mm*	600mm

\*CONSULT FACTORY



#### Angle Flanged Sizes

1.25"	1.5"	2"	2.5"	3"	4"	6"	8"	10"	12"	16"
32mm	40mm	50mm	65mm	80mm	100mm	150mm	200mm	250mm	300mm	400mm



#### Globe/Angle Screwed Sizes

1.25"	1.5"	2"	2.5"	3"
32mm	40mm	50mm	65mm	80mm



#### Globe/Angle Grooved Sizes

1.5"	2"	2.5"	3"	4"	*6"
32mm	50mm	65mm	80mm	100mm	150mm

\*Globe Only

TOLL FREE 1.888.628.8258 • phone: (918)627.1942 • fax: (918)622.8916 • 7400 East 42nd Place, Tulsa, Oklahoma 74145  
email: sales@controlvalves.com • website: www.controlvalves.com

## DIMENSIONS

U.S. DIMENSIONS - INCHES													
DIM	END CONN.	1 1/4-1 1/2	2	2 1/2	3	4	6	8	10	12	14	16	24
A	SCREWED	8 3/4	9 7/8	10 1/2	13	--	--	--	--	--	--	--	--
	GROOVED	8 3/4	9 7/8	10 1/2	13	15 1/4	20	--	--	--	--	--	--
	150# FLGD	8 1/2	9 3/8	10 1/2	12	15	17 3/4	25 3/8	29 3/4	34	39	40 3/8	62
	300# FLGD	8 3/4	9 7/8	11 1/8	12 3/4	15 5/8	18 5/8	26 3/8	31 1/8	35 1/2	40 1/2	42	63 3/4
B	SCREWED	1 7/16	1 11/16	1 7/8	2 1/4	--	--	--	--	--	--	--	--
	GROOVED	1*	1 3/16	1 7/16	1 3/4	2 1/4	3 5/16	--	--	--	--	--	--
	150# FLGD	2 5/16-2 1/2	3	3 1/2	3 3/4	4 1/2	5 1/2	6 3/4	8	9 1/2	10 5/8	11 3/4	16
	300# FLGD	2 5/8-3 1/16	3 1/4	3 3/4	4 1/8	5	6 1/4	7 1/2	8 3/4	10 1/4	11 1/2	12 3/4	18
C	SCREWED	4 3/8	4 3/4	6	6 1/2	--	--	--	--	--	--	--	--
	GROOVED	4 3/8*	4 3/4	6	6 1/2	7 5/8	--	--	--	--	--	--	--
	150# FLGD	4 1/4	4 3/4	6	6	7 1/2	10	12 11/16	14 7/8	17	--	20 13/16	--
ANGLE	300# FLGD	4 3/8	5	6 3/8	6 3/8	7 13/16	10 1/2	13 3/16	15 9/16	17 3/4	--	21 5/8	--
	SCREWED	3 1/8	3 7/8	4	4 1/2	--	--	--	--	--	--	--	--
	GROOVED	3 1/8*	3 7/8	4	4 1/2	5 5/8	--	--	--	--	--	--	--
D	150# FLGD	3	3 7/8	4	4	5 1/2	6	8	11 3/8	11	--	15 11/16	--
	300# FLGD	3 1/8	4 1/8	4 3/8	4 3/8	5 13/16	6 1/2	8 1/2	12 1/16	11 3/4	--	16 1/2	--
	SCREWED	6	6	7	6 1/2	8	10	11 7/8	15 3/8	17	18	19	27
E	ALL	3 7/8	3 7/8	3 7/8	3 7/8	3 7/8	3 7/8	6 3/8	6 3/8	6 3/8	6 3/8	6 3/8	8
F	ALL	6	6 3/4	7 11/16	8 3/4	11 3/4	14	21	24 1/2	28	31 1/4	34 1/2	52
G	ALL	10	11	11	11	12	13	14	17	18	20	20	28 1/2
H	ALL												

\*GROOVED END NOT AVAILABLE IN 1 1/4"

METRIC DIMENSIONS - M.M.													
DIM	END CONN.	DN32-DN40	DN50	DN65	DN80	DN100	DN150	DN200	DN250	DN300	DN350	DN400	DN600
A	SCREWED	222	251	267	330	--	--	--	--	--	--	--	--
	GROOVED	222	251	267	330	387	508	--	--	--	--	--	--
	150# FLGD	216	238	267	305	381	451	645	756	864	991	1026	1575
	300# FLGD	222	251	283	324	397	473	670	791	902	1029	1067	1619
B	SCREWED	37	43	48	57	--	--	--	--	--	--	--	--
	GROOVED	25*	30	37	44	57	84	--	--	--	--	--	--
	150# FLGD	59-64	76	89	95	114	140	171	203	241	270	298	406
	300# FLGD	67-78	83	95	105	127	159	191	222	260	292	324	457
C	SCREWED	111	121	152	165	--	--	--	--	--	--	--	--
	GROOVED	111*	121	152	165	194	--	--	--	--	--	--	--
	150# FLGD	108	121	152	152	191	254	322	378	432	--	529	--
ANGLE	300# FLGD	111	127	162	162	198	267	335	395	451	--	549	--
	SCREWED	79	98	102	114	--	--	--	--	--	--	--	--
	GROOVED	79*	98	102	114	143	--	--	--	--	--	--	--
D	150# FLGD	76	98	102	102	140	152	203	289	279	--	398	--
	300# FLGD	79	105	111	111	148	165	216	306	298	--	419	--
	SCREWED	152	152	178	165	203	254	302	391	432	457	483	686
E	ALL	98	98	98	98	98	98	162	162	162	162	162	203
F	ALL	152	171	195	222	298	356	533	622	711	794	876	1321
G	ALL	254	279	279	279	305	330	356	432	457	508	508	724
H	ALL												

\*GROOVED END NOT AVAILABLE IN DN32

For maximum efficiency, the OCV control valve should be mounted in a piping system so that the valve bonnet (cover) is in the top position. Other positions are acceptable but may not allow the valve to function to its fullest and safest potential. In particular, please consult the factory before installing 8" (DN200) and larger valves, or any valves with a limit switch, in positions other than described. Space should be taken into consideration when mounting valves and their pilot systems.

A routine inspection & maintenance program should be established and conducted yearly by a qualified technician. Consult our factory @ **1-888-628-8258** for parts and service.

### How to order your valve

When Ordering please provide:  
 Series Number - Valve size - Globe or Angle -  
 Pressure Class - Screwed, Flanged, Grooved -  
 Trim Material - Adjustment Range - Pilot  
 Options - Special needs / or installation requirements.

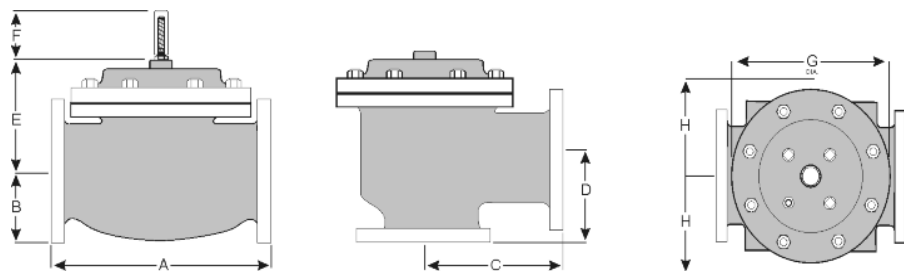

Represented by:

**TOLL FREE 1.888.628.8258** • phone: (918)627.1942 • fax: (918)622.8916 • 7400 East 42nd Place, Tulsa, Oklahoma 74145  
 email: sales@controlvalves.com • website: www.controlvalves.com