

The Model 120-7 is specifically designed for fuel loading systems and performs the following functions:

- ▶ Rate of flow control - valve will modulate as necessary to prevent set point from being exceeded
- ▶ Two-stage shutdown

SERIES FEATURES

- ▶ Opens on signal from preset register
- ▶ Limits flow rate to meter capacity (adjustable)
- ▶ Extra-sensitive differential pilot
- ▶ Closes in two stages based on signals from preset register
- ▶ Can be maintained without removal from the line
- ▶ Factory tested and can be pre-set to your requirements
- ▶ Explosion-proof prewired junction box available
- ▶ Two stage opening available via timer

OPERATION

(Refer to wiring diagram)
 On start-up, SW1 energizes the normally closed solenoid, allowing the valve to open. While open, the rate of flow pilot, sensing the differential across the integral orifice plate, will modulate the valve as necessary to prevent the flow rate from exceeding the pre-determined maximum. At a predetermined number of gallons prior to end of loading run, SW1 switches back to remove power from the normally closed solenoid and to make power available to the limit switch. The valve starts closed. At the low flow position, the limit switch reverses direction and energizes the normally open solenoid. This "hydraulically locks" the valve in the low flow position. At the conclusion of the load, SW2 switches back, de-energizing the normally open solenoid and the valve closes fully.

COMPONENTS

The Model 120-7 consists of the following components, arranged as shown on the schematic diagram:

- 1.) Model 65 Basic Control Valve (Fail Closed)
- 2.) Integral Orifice Plate
- 3.) Model 450 Two-Way Solenoid Pilot
- 4.) Model 451 Two-Way Solenoid Pilot
- 5.) Model 2450 Rate of Flow Control Pilot
- 6.) Model 126 Ejector
- 7.) Model 141-2 Needle Valve
- 8.) Model 123 Inline Strainer
- 9.) Limit Switch

SIZING

The following chart states the minimum and maximum flow rate with standard bore orifice plate, based on a fluid specific gravity of 0.8. This means the valve can be adjusted to control within the ranges shown. Lower flow ranges are possible through the use of smaller orifice plate bore and all ranges are adjustable within a 4:1 ratio (high to low flow). Consult the factory for assistance.

SIZE, DN	32-40	50	65	80	100	150	200	250	300	350	400	600
MIN FLOW, M ³ /HR	9	14	22	33	57	127	214	300	425	510	680	1990
MAX. FLOW, M ³ /HR	36	56	88	132	228	508	856	1200	1700	2040	2720	7960

SCHEMATIC

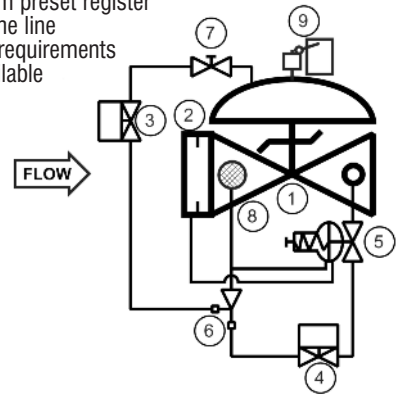

WIRING DIAGRAM

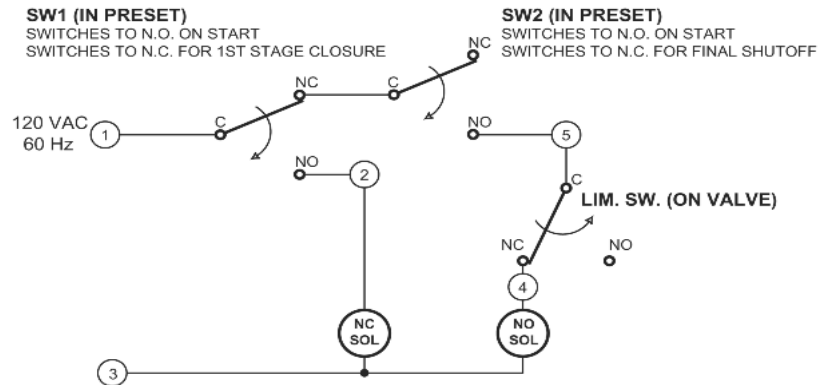

RECOMMENDED INSTALLATION

- ▶ Install the valve at the appropriate location, typically downstream of the preset meter.
- ▶ Install the valve with adequate space above and around the valve to facilitate servicing. Refer to the Dimension Table.
- ▶ Valve should be installed with the bonnet (cover) at the top, particularly 8" (DN200) and larger valves.
- ▶ Shut-off valves should be installed upstream and downstream of the control valve. These are used to isolate the valve during start-up and maintenance.
- ▶ Following main valve installation, the solenoids and limit switch must be wired into the preset register, as shown in the wiring diagram.

MAX. PRESSURE

END CONNECTIONS	DUCTILE IRON	STEEL WCB	STEEL LCB	STN. STL. CF8M	ALUMINUM
150# Flanged	17.2 bar	19.7 bar	18.4 bar	19.0 bar	19.7 bar
300# Flanged	44.1 bar	51.0 bar	48.0 bar	49.6 bar	----

SIZES

GLOBE/ANGLE

Flanged Ends:

1 1/4" - 24" (DN32 thru DN600) (globe);
1 1/4" - 16" (DN32 thru DN400) (angle)

TEMPERATURE RANGE

(Valve Elastomers)

Buna-N -40°C - 82°C

Viton -17°C - 204°C

MATERIALS

Consult factory for others.

Body/Bonnet: Ductile Iron (epoxy coated),
Carbon Steel (epoxy coated), Stainless Steel,
Aluminum

Seat Ring: Stainless Steel, Bronze

Stem: Stainless Steel, Monel

Spring: Stainless Steel

Diaphragm: Buna-N, Viton, (Nylon reinforced)

Seat Disc: Buna-N, Viton

Pilot: Stainless Steel, Bronze

Other pilot system components:

Stainless Steel, Bronze/Brass

Tubing & Fittings: Stainless Steel, Copper/Brass

SOLENOID

Enclosure: Explosion Proof NEMA 4X, 6P, 7, 9

Body: Brass, Stainless Steel

Voltages: 24, 120, 240, 480 VAC

12, 24 VDC

Note: Working pressures of solenoids vary greatly, consult factory on application of OCV Model 120-7 valves.

SPECIFICATIONS (Typical Fuel Application)

The two-stage preset valve shall open in one stage and close in two stages based on signals from the preset register. While open, the valve shall function to limit the flow rate to the adjustable setpoint, regardless of fluctuations in upstream or downstream pressure.

DESIGN

The two-stage preset valve shall be a single-seated, line pressure operated, diaphragm actuated, pilot controlled globe valve. The valve shall seal by means of a corrosion-resistant seat and a resilient, rectangular seat disc. These, and other parts, shall be replaceable without removing the valve from the line. The stem of the main valve shall be guided top and bottom by integral bushings. Alignment of the body, bonnet and diaphragm assembly shall be by precision dowel pins. The diaphragm shall not be used as a seating surface, nor shall the pistons be used as an operating means. The orifice plate shall be integrally installed in the valve inlet flange. The pilot system shall be furnished complete and installed on the main valve. It shall include two solenoid pilots, a needle valve and an inline strainer. The two-stage preset valve shall be operationally and hydrostatically tested prior to shipment.

MATERIALS OF CONSTRUCTION

The main valve body and bonnet shall be ductile iron per ASTM A536, Grade 65-45-12. All ferrous surfaces shall be coated with 4 mils of epoxy. The main valve seat ring shall be CF8M stainless steel. Elastomers (diaphragms, resilient seats and O-rings) shall be Buna-N. The control and solenoid pilots shall be stainless steel, as shall the needle valve and control line tubing. The orifice plate shall also be stainless steel. The solenoid and limit switch enclosures shall be explosion-proof and suitable for operation on <voltage>.

OPERATING CONDITIONS

The two-stage preset valve shall be suitable for controlling the flow rate at <X> m³/hr at pressures ranging from <X to X> bar.

ACCEPTABLE PRODUCTS

The two-stage preset valve shall be a <size> Model 120-7, <globe pattern, angle pattern>, with <150# flanged, 300# flanged> end connections, as manufactured by OCV Control Valves, Tulsa, Oklahoma, USA.

METRIC DIMENSIONS - M.M.

DIM	END CONN.	DN32-DN40	DN50	DN65	DN80	DN100	DN150	DN200	DN250	DN300	DN350	DN400	DN600
A	150# FLGD	216	238	267	305	381	451	645	756	864	991	1026	1575
	300# FLGD	222	251	283	324	397	473	670	791	902	1029	1067	1619
C	150# FLGD	108	121	152	152	191	254	322	378	432	--	529	--
	300# FLGD	111	127	162	162	198	267	335	395	451	--	549	--
D	150# FLGD	76	98	102	102	140	152	203	289	279	--	398	--
	300# FLGD	79	105	111	111	148	165	216	306	298	--	419	--
E	ALL	152	152	178	165	203	254	302	391	432	457	483	686
F	ALL	98	98	98	98	98	98	162	162	162	162	162	203
H	ALL	254	279	279	279	305	330	356	432	457	508	508	724

*GROOVED END NOT AVAILABLE IN DN32

CE Markings

Applies to fuel valves installed in the European Union in accordance with the Pressure Equipment Directive, 97/23/EC

CE-marked valves are available in LCB steel and CF8M stainless steel only

OCV is registered to the PED through Det Norske Veritas

The following valves will be CE-marked:

- 6" (DN150) and larger valves, 150# and 300# class, liquid fuel only
- 2" (DN50) thru 4" (DN100) valves, 300# class, liquid fuel
- 1 1/4" (DN32) thru 4" (DN100) valves, 300# class, LPG or Butane service
- 4" (DN100) and smaller valves in Class 150# (liquids) are furnished under SEP with no CE-mark

For maximum efficiency, the OCV control valve should be mounted in a piping system so that the valve bonnet (cover) is in the top position. Other positions are acceptable but may not allow the valve to function to its fullest and safest potential. In particular, please consult the factory before installing 8" (DN200) and larger valves, or any valves with a limit switch, in positions other than described. Space should be taken into consideration when mounting valves and their pilot systems.

A routine inspection & maintenance program should be established and conducted yearly by a qualified technician. Consult our factory @ **1-918-627-1942** for parts and service.

How to order your Model 120-7 valve

When ordering please provide:

Fluid to be controlled - Model Number - Size - Globe or Angle - End Connection - Body Material - Trim Material - Flow Rate Setting or Range - Solenoid Voltage - Special Requirements / Installation Requirements

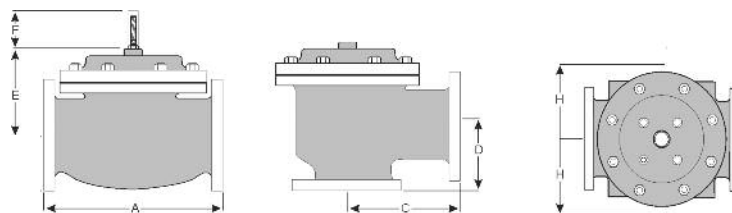

QUALITY SYSTEM
REGISTERED TO
ISO 9001

phone: (918)627.1942 ● fax: (918)622.8916 ● 7400 East 42nd Place, Tulsa, Oklahoma 74145
email: sales@controlvalves.com ● website: www.controlvalves.com