



▲ Model 108FCA

FIRE PUMP RELIEF VALVE

The Model 108FC automatically relieves excess fire pump discharge pressure, to prevent the pressure from exceeding the rating of the fire system components.

SERIES FEATURES

- ▶ Limits maximum pump discharge pressure
- ▶ Opens quickly; maintains pressure within close limits
- ▶ Adjustable: 4.1 - 12.4 bar or 6.9 - 20.7 bar
- ▶ Pilot-operated main valve
- ▶ Pressure setting is adjustable with single screw
- ▶ Factory tested and pre-set to your requirements
- ▶ UL Listed & Factory Mutual Approved for both split-case centrifugal and vertical turbine pumps
- ▶ Sizes 3" (DN80) - 8" (DN200), globe and angle pattern
- ▶ ANSI Flanged Class 150, Class 300, and 300 inlet x 150 outlet
- ▶ Wide range of materials available

OPERATION

The normally closed, spring loaded pilot, sensing pump discharge pressure, opens when pressure exceeds the spring setting, allowing the main valve to open. As the pump pressure increases the pilot controls the main valve to open further. Pressure is maintained at the controlled set point over a wide range of flows regardless of back pressure in the downstream piping. The valve closes gradually as pressures decrease below the set point.

COMPONENTS

The Model 108FC consists of the following components, arranged as shown on the schematic diagram:

- 1.) **Model 65 Basic Control Valve** (angle pattern shown), a hydraulically-operated, diaphragm-actuated, globe or angle valve which closes with an elastomer-on-metal seal.
- 2.) **Model 1330FC Pressure Relief Pilot**, a two-way, normally-closed pilot valve which senses upstream pressure under its diaphragm and balances it against an adjustable spring load. An increase in upstream pressure tends to make the pilot open.
- 3.) **Model 126 Ejector**, a simple "tee" fitting with a fixed orifice in its inlet port. It provides the proper pressure to the diaphragm chamber of the main valve depending on the position of the pressure relief pilot.
- 4.) **Model 141-1 Check Valve**, that prevents the valve from opening under a vacuum condition that may be encountered with a vertical turbine pump.
- 5.) **Model 159 Y-Strainer** The strainer protects the pilot system from solid contaminants in the line fluid.
- 6.) **Pressure Gauge**
- 7.) **Model 155 Visual Indicator** (optional), enables user to determine valves' operating position.

SCHEMATIC

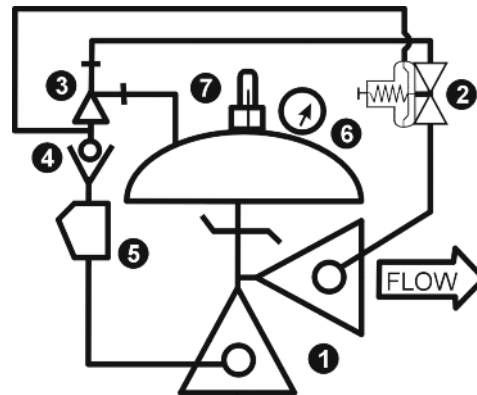

TYPICAL INSTALLATION

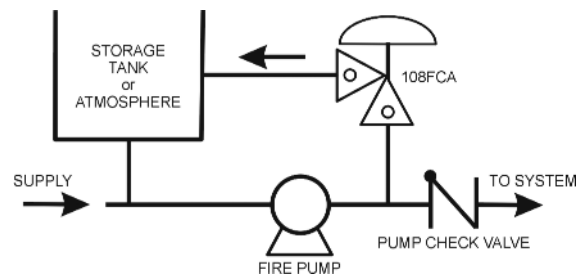

SIZING

Fire pump relief valves are sized per the guidelines in NFPA 20, and are based on the rated flow of the pump.

VALVE SIZE	MAX. PUMP FLOW, M ³ /HR	MAX PRESSURE SETTING, BAR
3" (DN80)	114	20.7 (UL) 12.0 (FM)
4" (DN100)	227	20.7 (UL) 12.0 (FM)
6" (DN150)	568	20.7 (UL) 12.0 (FM)
8" (DN200)	1136	12.0 (UL & FM)

TOLL FREE 1.888.628.8258 • phone: (918)627.1942 • fax: (918)622.8916 • 7400 East 42nd Place, Tulsa, Ok 74145
 email: sales@controlvalves.com • website: www.controlvalves.com

Model 108FC(Globe)/108FCA(Angle) METRIC



SIZES

GLOBE - 3" (DN80), 4" (DN100),
6" (DN150), 8" (DN200)
ANGLE - 3" (DN80), 4" (DN100),
6" (DN150), 8" (DN200)

SPRING RANGES

4.1 - 12.4 bar standard for UL / FM
6.9 - 20.7 bar standard for UL, sizes 3"
(DN80), 4" (DN100), 6" (DN150), Class
300 and 300 x 150

TEMPERATURE RANGE

(Buna-N Elastomers)
0°C - 82°C

MATERIALS

Body/Bonnet:

- Ductile Iron ASTM A536-epoxy coated (standard)
- Cast Steel ASTM A216 WCB - epoxy coated
- Stainless Steel ASTM A743 CF8M
- Nickel-aluminum Bronze ASTM B148 Alloy C95800

Seat Ring:

- Bronze (standard)
- Stainless Steel ASTM A743CF8M (optional)
- Nickel-aluminum Bronze ASTM B148 Alloy C95800 (optional)

Stem:

Stainless Steel (standard), Monel

Spring:

Stainless Steel

Diaphragm:

Nylon Reinforced Buna-N

Seat Disc:

Buna-N

Pilot:

- Cast Bronze (standard)
- Stainless Steel ASTM A743CF8M (optional)
- Nickel-aluminum Bronze ASTM B148 Alloy C95800 (optional)

Tubing/Fittings:

- Copper/brass (standard)
- Stainless Steel (optional)

SPECIFICATIONS

The fire pump relief valve shall function to limit pump discharge pressure.

DESIGN

The valve shall be a single-seated, line pressure operated, diaphragm actuated, pilot controlled globe or angle valve. The valve shall seal by means of a corrosion-resistant seat and resilient, rectangular seat disc. These and other parts shall be replaceable without removing the valve from the line. The stem of the main valve shall be guided top and bottom by integral bushings. Alignment of the body, bonnet and diaphragm assembly shall be by precision dowel pins. The diaphragm shall not be used as a seating surface, nor shall pistons be used as an operating means. The pilot system shall be furnished complete and installed on the main valve, and shall include a Y-strainer and bonnet mounted pressure gauge. The valve shall be operationally and hydrostatically tested prior to shipment.

MATERIALS OF CONSTRUCTION

The main valve body and bonnet shall be ductile iron per ASTM A536, Grade 65-45-12 (or other materials refer to MATERIALS). All internal ferrous surfaces shall be coated with 4 mils of epoxy. External surfaces shall be coated with 4 mils of epoxy followed by a coat of fire red enamel paint. The main valve seat ring shall be bronze (or other materials refer to MATERIALS). Elastomers (diaphragms, resilient seats, and O-rings) shall be Buna-N. Control pilot shall be bronze (or other materials refer to MATERIALS). The control line tubing shall be copper (or other materials refer to MATERIALS).

ACCEPTABLE PRODUCTS

The fire pump relief valve shall be a Model 108FC (globe) or 108FCA (angle), UL Listed and/or Factory Mutual Approved, sized per NFPA 20 and as manufactured by OCV Control Valves, Tulsa, OK, USA.

U.S. DIMENSIONS (INCHES)

DIM	FLANGES	3	4	6	8
A	150#	12	15	17 3/4	25 3/8
	300#	12 3/4	15 5/8	18 5/8	26 3/8
	300#X150#	12 3/4	15 5/8	18 5/8	26 3/8
C	150#	6	7 1/2	10	12 11/16
	300#	6 3/8	7 13/16	10 1/2	13 3/16
	300#X150#	6 3/8	7 13/16	10	12 11/16
D	150#	4	5 1/2	6	8
	300#	4 3/8	5 13/16	6 1/2	8 1/2
	300#X150#	4 3/8	5 13/16	6 1/2	8 1/2
E	ALL	6 1/2	8	10	11 7/8
	ALL	3 7/8	3 7/8	3 7/8	6 3/8
H	ALL	11	12	13	14

METRIC DIMENSIONS (MILLIMETERS)

DIM	FLANGES	DN80	DN100	DN150	DN200
A	150#	305	381	451	645
	300#	324	397	473	670
	300#X150#	324	397	473	670
C	150#	152	191	254	322
	300#	162	198	267	335
	300#X150#	162	198	254	322
D	150#	102	140	152	203
	300#	111	148	165	216
	300#X150#	111	148	165	216
E	ALL	165	203	254	302
	ALL	98	98	98	162
H	ALL	279	305	330	356

For maximum efficiency, the OCV control valve should be mounted in a piping system so that the valve bonnet (cover) is in the top position. Other positions are acceptable but may not allow the valve to function to its fullest and safest potential. In particular, please consult the factory before installing 8" (DN200) and larger valves, or any valves with a limit switch, in positions other than described. Space should be taken into consideration when mounting valves and their pilot systems.

A routine inspection & maintenance program should be established and conducted yearly by a qualified technician. Consult our factory @ **1-888-628-8258** for parts and service.

How to order your valve

When Ordering please provide:
Series Number - Valve size - Globe or Angle - Pressure Class - Flanged - Trim Material - Adjustment Range - Pilot Options - Special needs / or Installation Requirements

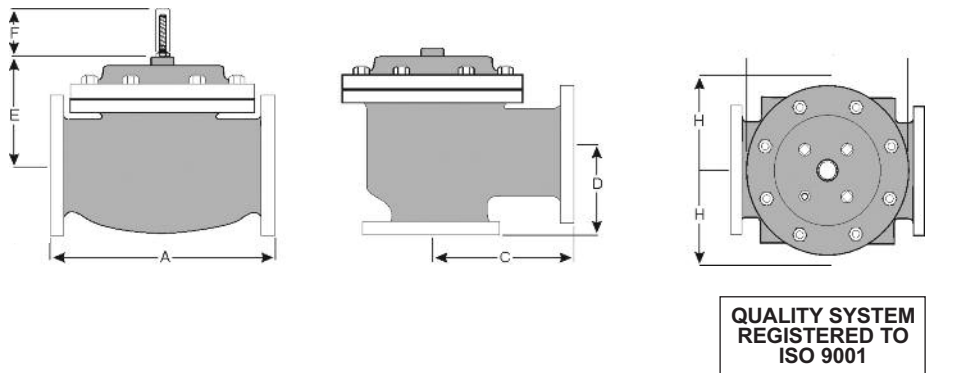

Represented by:

TOLL FREE 1.888.628.8258 • phone: (918)627.1942 • fax: (918)622.8916 • 7400 East 42nd Place, Tulsa, Oklahoma 74145
email: sales@controlvalves.com • website: www.controlvalves.com