

back pressure control valve

installation, operating and maintenance instructions

BPCV-101

model 108-34

GENERAL DESCRIPTION

The OCV Model 108-34 may be generically described as a back pressure control valve, or pressure sustaining valve. It functions to control the incoming pressure at the set point, or more commonly, to prevent the pressure from falling below a predetermined minimum. For example, it may be installed on the discharge of a pump to ensure that the pump remains “on its curve”.

The 108-34 performs the above functions only when its solenoid is energized. With the solenoid deenergized, the valve is tightly closed.

The 108-34 also includes a check feature, enabling it to close tightly in the event of pressure reversal to prevent backflow.

The Model 108-34 consists of the following components, arranged as shown on the schematic diagram:

1. **Model 65 Basic Control Valve**, a hydraulically-operated, diaphragm-actuated, globe or angle valve which closes with an elastomer-on-metal seal.
2. **Model 1330 Pressure Relief Pilot**, a two-way, normally-closed pilot valve which senses upstream pressure under its diaphragm and balances it against an adjustable spring load. An increase in upstream pressure tends to make the pilot open.
3. **Model 451 Solenoid Pilot**, a two-way, normally-closed, electrically-actuated valve. Applying power to the solenoid coil causes the pilot to open.
4. **Model 126 Ejector**, a simple “tee” fitting with a

fixed orifice in its inlet port. It provides the proper pressure to the diaphragm chamber of the main valve depending on the position of the pressure relief pilot.

5. **Model 141-3 Flow Control Valve**, a needle-type valve which provides adjustable, restricted flow in one direction, and free flow in the opposite direction. On the 108-34, the flow control valve is connected as a **closing speed control**.
6. Two **Model 141-1 Check Valves**, which enable the 108-34 to function as a check valve.
7. **Model 123 Inline Strainer**, which protects the

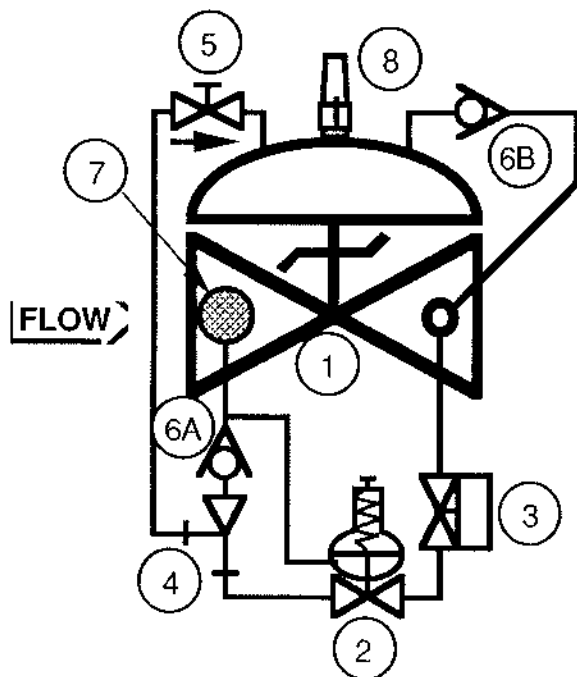

pilot system from solid contaminants in the line fluid.

8. **Model 155L Visual Indicator Assembly**, which enables the user to determine the valve's operating position at a glance.

BACK PRESSURE CONTROL ACTION: To understand how the 108-34 operates, it is best to start with the **Ejector (4)**. Due to the orifice in its upstream port, the ejector creates a pressure drop proportional to the flow through it. The flow through the ejector is in turn controlled by the degree of opening of the **Pressure Relief Pilot (2)**. The **wider** the pilot **opens**, the **greater** the flow through the ejector and the **lower** the pressure downstream of the orifice. Conversely, the **more** the pilot **closes**, the **lower** the flow through the ejector and the **greater** the pressure downstream of the orifice.

Now note that the diaphragm chamber of the **Main Valve (1)** is connected to the branch port of the ejector and is thus downstream of the orifice. Therefore, the pressure in the diaphragm chamber of the main valve is effectively controlled by the pressure relief pilot, in the manner described above. As the pilot **opens**, the diaphragm pressure **decreases** and the main valve **opens**; as the pilot **closes**, the diaphragm pressure **increases** and the main valve **closes**.

If the 108-34 is installed as a **pressure sustaining valve**, the pressure upstream of the main valve is normally above the set point of the relief pilot. Therefore, the pilot is wide open as is the main valve. However, if system demand increases to the point that the upstream pressure tries to fall below the set point, the pilot will start to close and the main valve will follow, throttling as required to keep the pressure from falling any further.

ELECTRICAL ON-OFF ACTION: Notice that the **solenoid pilot (3)** is connected in series with the ejector and the relief pilot, thus its action has much the same effect on the main valve as does the relief pilot. When its coil is energized, the solenoid pilot opens fully. Thus the main valve can open as **directed** by the relief pilot. With its coil deenergized, the solenoid pilot closes fully. Thus full pressure builds up on the diaphragm chamber of the main valve and the valve closes fully, **despite** any further action by the relief pilot.

CHECK FEATURE: In the event downstream pressure becomes higher than upstream pressure, **check**

valve (6B) opens to direct the downstream pressure to the diaphragm chamber, forcing the main valve fully and tightly closed. At the same time, **check valve (6A)** closes to prevent ant backflow through the pilot system. Notice that this action will occur regardless of the position of the solenoid pilot or relief pilot.

INSTALLATION

The 108-34 is furnished fully factory-assembled and ready for installation at the appropriate point in the system. For full installation details, the user is referred to the Model 65 Basic Valve section of this manual.

Once the main valve is installed, the solenoid pilot must be wired into the control circuit. This is a simple two-wire hookup.

Finally, the limit switch is wired into the remote indication system. The interior switch is single-pole, double-throw (SPDT).

STARTUP AND ADJUSTMENTS

The following procedures should be followed in the order presented in order to affect an initial startup of the 108-34.

1. Install a pressure gauge of the proper range upstream of the 108-34. The unused **inlet** side port in the main valve body may be used for this purpose if there is no convenient location in the upstream piping.
2. Remove the plastic cap from the pressure relief pilot (2) and loosen the adjusting screw jam nut. Turn the adjusting screw **counterclockwise** until it is loose enough to be turned with the fingers.
3. Loosen the adjusting screw jam nut on flow control valve (5) (closing speed control). Turn the adjusting screw **clockwise** to a full stop, then **counterclockwise** three full turns.
4. Make sure the solenoid pilot (3) is deenergized.
5. Start the pump or otherwise start the system flowing. The main valve at this time should be fully closed.
6. Carefully loosen a pipe plug in the main valve bonnet until fluid begins to discharge around the threads. When only clear fluid (no air) is discharging, retighten the plug.
7. Energize the solenoid pilot (3). The main valve should open fully.
8. Observing the inlet pressure gauge, open valves

or otherwise increase flow until the pressure falls to a point approximately 5 psi **below** the desired set point.

9. Slowly turn the adjusting screw of the pressure relief pilot (2) **clockwise** until the pressure rises to **the set point**. Tighten the adjusting screw jam nut and replace the plastic cap.
10. Deenergize the solenoid pilot (3) and observe the closing speed of the valve. Ideally, the valve should close just slow enough to avoid inducing any surges in the system. Turn the adjusting screw of the flow control valve (5) **clockwise** to **decrease** closing speed; **counterclockwise** to **increase** closing speed. **CAUTION: Do NOT adjust the flow control valve fully closed. To do so can keep the valve from closing at all.**
11. Shut down the pump.

MAINTENANCE

Because of the simplicity of design of the 108-34, required maintenance is minimal. However, the following checks, periodically performed, can do much to keep the valve operating properly and efficiently.

1. Check for leaks at fittings and around flanges and connections. Tighten as required.
2. Check that electrical wiring and connections are secure.

TROUBLESHOOTING

In the event of malfunction of the 108-34, the following guide should enable the technician to isolate the specific cause of the problem and take the appropriate corrective action.

MAIN VALVE FAILS TO OPEN

1. Valve closed upstream or downstream of the 108-34 — Open as required.
2. Pressure relief pilot (2) adjusted too far clockwise — See Adjustment instructions.
4. Coil of solenoid pilot (3) not energized. — Check control circuit.
4. Diaphragm of pressure relief pilot (2) ruptured. This will be evidenced by a discharge of fluid from the vent hole in the pilot bonnet — Replace diaphragm. See the 1330 Pilot section of this manual.
5. Solenoid pilot (3) stuck closed or coil burned out — See the Solenoid Valve section of this manual.

6. Stem of pressure relief pilot (2) binding — Disassemble pilot and determine cause. See the 1330 Pilot section of this manual.
7. Main valve diaphragm ruptured — Disassemble main valve and replace diaphragm. See the Model 65 Basic Valve section of this manual.
8. Stem of main valve binding — Disassemble valve and determine cause. See the Model 65 Basic Valve section of this manual.

MAIN VALVE FAILS TO CLOSE

1. Closing speed control (5B) adjusted fully closed — Open as required. See Adjustment instructions.
2. Solenoid pilot (3) not deenergized — Check control circuit.
3. Pressure relief pilot (2) adjusted too far counterclockwise — See Adjustment instructions.
4. Solenoid pilot (3) stuck open or seat badly deteriorated — Disassemble pilot and determine cause. See the Solenoid Valve section of this manual.
5. Pressure relief pilot (2) stem binding or seat badly deteriorated — Disassemble pilot and determine cause. See the 1330 Pilot section of this manual.
6. Check valve (6B) leaking — Disassemble check valve and determine cause. Repair or replace as necessary.
7. Check valve (6A) stuck closed — Disassemble check valve and determine cause. Repair or replace as necessary.
8. Strainer (7) clogged — Clean as required.
9. Main valve stem binding or object caught in valve — Disassemble valve and determine cause. See the Model 65 Basic Valve section of this manual.

MAIN VALVE LEAKS WHEN CLOSED

1. Pressure relief pilot (2) adjusted slightly too low — See Adjustment Instructions.
2. Damaged seat in solenoid pilot (3) — Disassemble pilot and determine cause. See the Solenoid Valve section of this manual.
3. Damaged seat in relief pilot (2) — Disassemble pilot and determine cause. See the 1330 pilot section of this manual.
4. Damaged seat in main valve. — Disassemble valve and determine cause. See the Model 65 Basic Valve section of this manual.



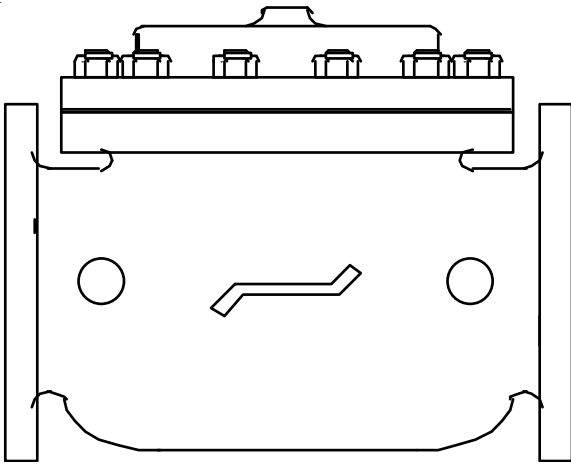

installation, operating, and maintenance instructions

series 65 basic control valve

GENERAL DESCRIPTION

The OCV Series 65 is a hydraulically-operated, diaphragm-actuated valve. It is available in either a globe (Model 65) or angle (Model 65A) configuration. The diaphragm is nylon-fabric bonded with synthetic rubber and forms a sealed chamber in the upper portion of the valve, separating operating pressure from line pressure. An elastomeric seat disc forms a tight seal with the valve seat when pressure is applied above the diaphragm.

FUNCTIONAL DESCRIPTION

Because the Series 65 is a hydraulically operated valve, it requires a minimum line pressure of approximately 5 psig in order to function. The valve functions on a simple principle of pressure differential. The line pressure at the inlet of the valve is bypassed through the pilot control piping to the diaphragm chamber of the valve. This pressure, together with the valve spring, works against the pressure under the valve seat. Because the effective area of the diaphragm is greater than that of the seat, the valve is held tightly closed. As the controlling pilot(s) allow the pressure to bleed off the diaphragm chamber, the two opposing pressures begin to balance and the valve will begin to open. The valve can be used to perform a simple on-off function, or with the proper pilot system, a modulating, or regulating function.

In cases where the line fluid is unusually dirty, or is otherwise unsuitable for operating the valve, an independent operating pressure source may be employed. The pressure available from such a source must be equal to, or greater than, line pressure.

INSTALLATION

In order to insure safe, accurate and efficient operation of the OCV control valve, the following list of checkpoints and procedures should be followed when installing the

valve.

1. Make a careful visual inspection of the valve to insure that there has been no damage to the external piping, fittings or controls. Check that all fittings are tight.
2. Thoroughly flush all interconnecting piping of chips, scale and foreign matter prior to mounting the valve.
3. Install the valve in the line according to the flow arrow on the inlet flange. The arrow should point downstream.
4. Allow sufficient room around the valve for ease of adjustment and maintenance service.

In addition, it is highly recommended that:

1. Isolation valves (eg., gate or butterfly) be installed on the inlet and discharge sides of the valve to facilitate isolating the valve for maintenance.
2. Pressure gauges be installed at the inlet and outlet sides of the valve to provide monitoring of the valve during initial start-up and during operation. The body side ports, if unused by the pilot system, provide a convenient connection for the gauges.
3. All valves larger than 6" be installed horizontally, i.e., with the bonnet pointed up, for ease of adjustment and maintenance servicing.

MAINTENANCE

The OCV control valve requires no lubrication and a minimum of maintenance. However, a periodic inspection should be established to determine how the fluid being handled is affecting the efficiency of the valve. In a water system, for example, the fluid velocity as well as the substances occurring in natural waters, such as dissolved minerals and suspended particles, vary in every installation. The effect of these actions or substances must be determined by inspection. It is recommended that an annual inspection, which includes ex-

amination of the valve interior, be conducted. Particular attention should be paid to the elastomeric parts, i.e., the diaphragm and seat disc. Any obviously worn parts should be replaced.

REPAIR PROCEDURES

In the event of malfunction of the OCV control valve, troubleshooting should be conducted according to the procedures outlined for the specific model of valve. Then, if those steps indicate a problem with the main valve, this section will outline the procedures necessary to correct the problem.

Problems with the main valve can be classed in three basic categories:

1. VALVE FAILS TO OPEN
 - a. Diaphragm damaged* - See Procedure A
 - b. Stem binding - See Procedure B
2. VALVE FAILS TO CLOSE
 - a. Diaphragm damaged* - See Procedure A
 - b. Stem binding - See Procedure B
 - c. Object lodged in valve - See Procedure B
3. VALVE OPENS AND CLOSES BUT LEAKS WHEN CLOSED
 - a. Seat disc damaged - See Procedure C
 - b. Seat ring damaged - See Procedure D

*A diaphragm failure can prevent the valve from either opening or closing, depending on the flow direction. Most water service valves flow "under the seat", in which case a diaphragm failure will keep the valve from closing. On the other hand, most fuel service valves flow "over the seat", in which case a diaphragm failure will keep the valve from opening. To determine which you have, examine the bridge mark cast into the side of the valve body, then compare it with the figures below.

PROCEDURE A : DIAPHRAGM REPLACEMENT

1. Isolate the valve from the system by closing upstream and downstream block valves.
2. Loosen one of the tubing connections on the bonnet. Allow any residual pressure to bleed off.
3. Remove all tubing connected at the bonnet.
4. Remove the bonnet nuts.
5. Remove the bonnet. If the bonnet sticks in place, it may be loosened by rapping sharply around its edge with a rubber-headed mallet. *NOTE: 8" and larger valves are equipped with eye bolts through which a chain can be fastened to aid in*

lifting the bonnet.

6. Remove the spring.
7. Remove the diaphragm plate capscrews and the diaphragm plate.
8. Remove the old diaphragm.
9. Making sure the dowel pin holes are in the proper location, place the new diaphragm over the studs and press down until it is flat against the body and spool.
10. Replace the diaphragm plate and the diaphragm plate capscrews.
11. Tighten all diaphragm plate capscrews snugly.
12. Replace the spring.
13. Replace the bonnet and reinstall the bonnet nuts.
14. Tighten the bonnet nuts snugly using a criss-cross tightening pattern.
15. Reinstall the control tubing.
16. Reopen the upstream and downstream block valves.
17. Before placing the valve back in service, perform the air bleed procedure described in the first section of this manual.

PROCEDURE B: CORRECTION OF BINDING STEM

1. Perform Steps 1 thru 6 of Procedure A, above.
2. Remove the spool assembly from the valve. *NOTE:*

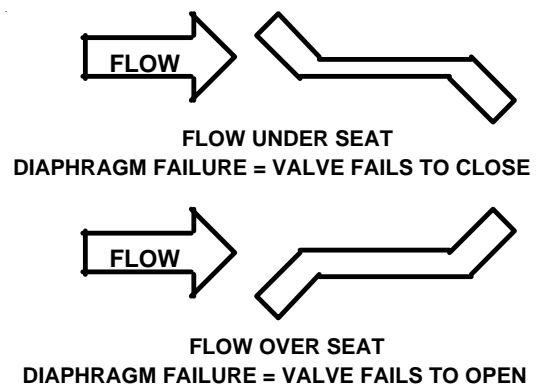

On smaller valves, this can be accomplished simply by grasping the stem and pulling upward. Valves 6" and larger have the top of the stem threaded to accept an eyebolt to aid in lifting the spool out of the body. 6" thru 12" valves are threaded 3/8-16. 14" and 16" valves are threaded 5/8-11.

3. Carefully examine both ends of the stem for deep scratches, scoring or buildup of mineral deposits.

Polish the stem if necessary using a fine grade of emery cloth.

4. Similarly, examine and polish the upper bushing (in the bonnet) and the lower guide (in the seat ring).
5. Reinstall the spool assembly.
6. Reassemble the valve, following Steps 12 thru 17 in Procedure A.

PROCEDURE C: SEAT DISC REPLACEMENT

1. Perform Steps 1 and 2 of Procedure B, above.
2. With the spool assembly removed from the body, remove the seat retainer screws.
3. Slide the seat retainer off the lower end of the stem.
4. Remove the seat disc from its groove in the spool.
NOTE: The seat disc may fit quite tightly in the groove. If necessary, it may be pried out using a thin-bladed screwdriver or similar tool.
5. Install the new seat disc in the groove.
6. Reinstall the seat retainer and tighten the seat retainer screws.
7. Reassemble the valve, following Steps 5 and 6 of Procedure B.

PROCEDURE D: SEAT RING REPLACEMENT

NOTE: It is rare for a seat ring to require replacement. Minor nicks and scratches in the seating surface can usually be smoothed out with emery cloth.

1. Perform Steps 1 and 2 of Procedure B, above.
2. If you are working on a 4" or smaller valve, follow Steps 3 thru 9, below.
3. If you are working on a 6" or larger valve, follow Steps 10 thru 16, below.

4. Seat rings in valves 4" and smaller are threaded into the valve body. To remove, you will need a special seat ring tool. You may fabricate one using standard pipe as shown in the sketch below, or one may be purchased from OCV.
5. Using the seat ring tool, unthread the seat ring from the body.
6. Remove the old o-ring from the counterbore in the body.
7. Install the new o-ring in the counterbore.
8. Using the seat ring tool, install the new seat ring.
9. Reassemble the valve, following Steps 5 & 6 of Procedure B.
10. Seat rings in valves 6" and larger are bolted into the body with socket head capscrews. In addition you will note that the seat ring is equipped with additional threaded holes that may be used for "jacking" the seat ring out of the body.
11. Remove the socket head capscrews.
12. Remove the old seat ring from the body by temporarily installing two or more of the capscrews in the "jacking" holes.
13. Install a new o-ring in the groove of the new seat ring. Lubricate the o-ring and outer seat ring wall with Vaseline® or similar lubricant.
14. Install the new seat ring in the body, making sure that the capscrew holes line up.
15. Replace and tighten all the capscrews.
16. Reassemble the valve, following Steps 5 and 6 of Procedure B.

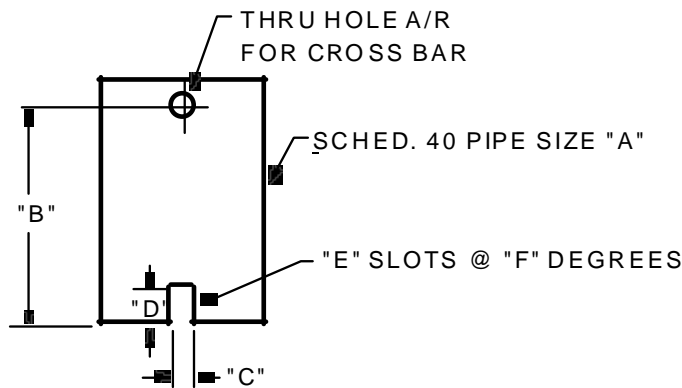

VALVE SIZE	"A" PIPE SIZE	"B" MIN. LENGTH	"C" SLOT WIDTH	"D" SLOT DEPTH	"E" NO. OF SLOTS	"F" SLOT SPACING
1-1/4"	3/4"	6"	3/8"	3/8"	2	180°
1-1/2"	3/4"	6"	3/8"	3/8"	2	180°
2"	1-1/2"	7"	3/8"	3/8"	2	180°
2-1/2"	2"	8"	1/2"	1/2"	3	120°
3"	2-1/2"	9"	5/8"	5/8"	2	180°
4"	3"	10"	5/8"	5/8"	2	180°

REVISED 3-17-97

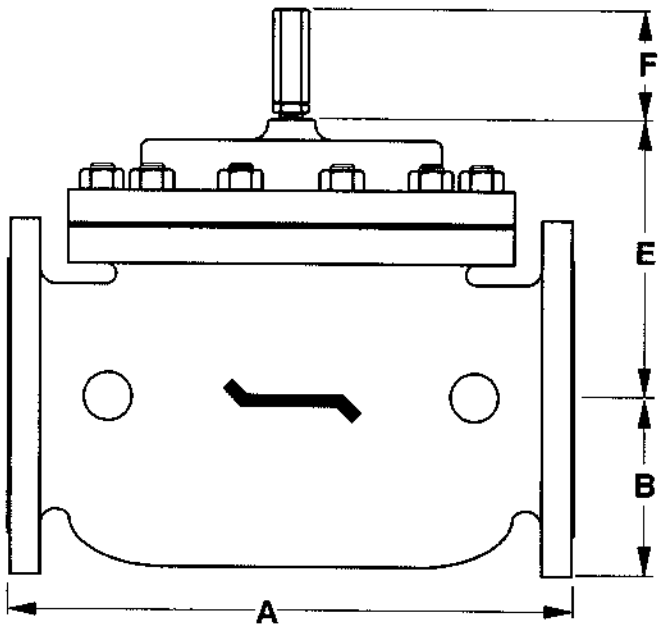
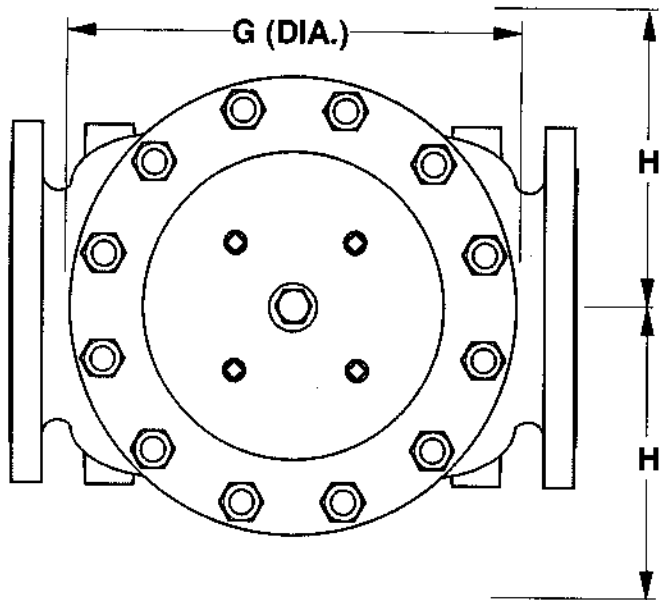

DIM	ANSI CLASS	VALVE SIZE												
		1 1/4	1 1/2	2	2 1/2	3	4	6	8	10	12	14	16	24
A	SE	8.75	8.75	9.88	10.50	13.00	-	-	-	-	-	-	-	-
	150	8.50	8.50	9.38	10.50	12.00	15.00	17.75	25.38	29.75	34.00	39.00	40.38	62.00
	300	8.75	8.75	9.88	11.12	12.75	15.62	18.62	26.38	31.12	35.50	40.50	42.00	63.75
B	SE	1.44	1.44	1.69	1.88	2.25	-	-	-	-	-	-	-	-
	150	2.31	2.50	3.00	3.50	3.75	4.50	5.50	6.75	8.00	9.50	10.62	11.75	16.00
	300	2.62	3.06	3.25	3.75	4.12	5.00	6.25	7.50	8.75	10.25	11.50	12.75	18.00
C	SE	4.38	4.38	4.75	6.00	6.50	-	-	-	-	-	-	-	-
	150	4.25	4.25	4.75	6.00	6.00	7.50	10.00	12.69	14.88	17.00	-	20.81	-
	300	4 3/8	4.38	5.00	6.38	6.38	7.81	10.50	13.19	15.56	17.75	-	21.62	-
D	SE	3.12	3.12	3.88	4.00	4.50	-	-	-	-	-	-	-	-
	150	3.00	3.00	3.88	4.00	4.00	5.50	6.00	8.00	11.38	11.00	-	15.69	-
	300	3.25	3.25	4.12	4.38	4.38	5.81	6.50	8.50	12.06	11.75	-	16.50	-
E	ALL	6.00	6.00	6.00	7.00	6.50	7.92	10.00	11.88	15.38	17.00	18.00	19.00	27.00
F	ALL	3.88	3.88	3.88	3.88	3.88	3.88	3.88	6.38	6.38	6.38	6.38	6.38	8.00
G	ALL	6.00	6.00	6.75	7.69	8.75	11.75	14.00	21.00	24.50	28.00	31.25	34.50	52.00
H	ALL	10.00	10.00	11.00	11.00	11.00	12.00	13.00	14.00	17.00	18.00	20.00	20.00	28.50

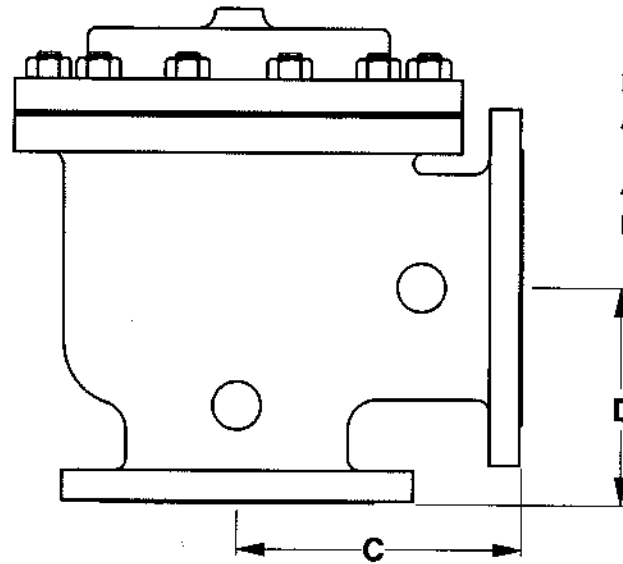

NOTE: 3" VALVE DIMENSIONS ARE FOR NEW MODEL 3100

4" VALVE DIMENSIONS ARE FOR NEW MODEL 4400

REV. A SDJ 6-6-02
REV. B SDJ 2-3-03

TOLERANCES		 OCV Control Valves TULSA, OKLAHOMA U.S.A.		
UNLESS NOTED FRACTIONAL $\pm 1/64$ DECIMAL $\pm .005$ MACH. FINISH 125/ ANGULAR $\pm 1/2^\circ$				
GENERAL VALVE DIMENSIONS				
DRAWN BY SDJ	DATE 10-6-97	SIZE A	DRAWING NUMBER 65D	REV. B
CHKD. BY	DATE			

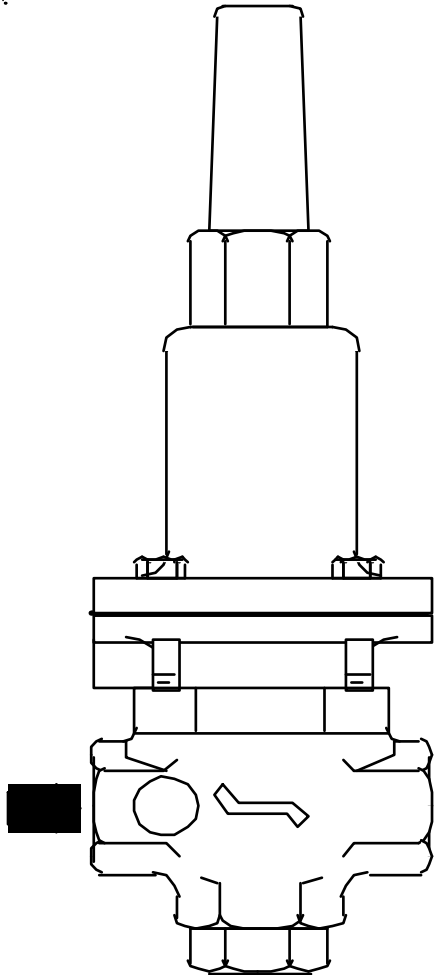

installation, operating, and maintenance instructions

pressure sustaining/ pressure relief pilot

model 1330

GENERAL DESCRIPTION

The Model 1330 Pressure Sustaining/Pressure Relief Pilot is a normally-closed, direct-acting, spring-loaded, diaphragm-type control pilot. As the primary control pilot for the OCV Series 108 control valves, it is designed to maintain a constant preset inlet pressure on the main valve. It is a constant throttling device, maintaining precise, positive control of the main valve.

The 1330 may also be used by itself as a back pressure regulator.

The 1330 is available in bronze or stainless steel construction and with 3/8 NPT or 1/2 NPT end connections.

The 1330 is available with four different adjustment ranges:

5-30 psi	65-180 psi
20-80 psi	100-300 psi

FUNCTIONAL DESCRIPTION

The 1330 controls the pressure in the diaphragm cham-

ber of the main valve, hence the degree of opening or closing of the valve. The upstream pressure is sensed under the diaphragm of the pilot and is balanced against an adjustable spring load. As the upstream pressure increases above the set point, the pilot opens wider, decreasing the pressure in the diaphragm chamber of the main valve, opening the valve a proportionate amount. Conversely, as upstream pressure decreases below the set point, the pilot closes further, increasing the pressure in the diaphragm chamber of the main valve, closing the valve a proportionate amount. The net result is a constant modulating action of the pilot and main valve, keeping the upstream pressure at the set point within very close limits.

INSTALLATION AND ADJUSTMENT

The 1330 is normally installed in the main valve control piping between the ejector and the downstream body tap. Flow must be in the direction indicated. A sensing line, typically 1/4" O.D. tubing, must be installed between the pilot sense port and the upstream

control piping ahead of the ejector.

Pressure adjustment is made by means of the single adjusting screw:

Clockwise adjustment **increases** upstream pressure.

Counterclockwise adjustment **decreases** upstream pressure.

MAINTENANCE

Required maintenance of the 1330 is minimal. Fittings and bolts should be periodically checked, and the body should be inspected for damage or excessive buildup of foreign material.

TROUBLESHOOTING

Other than improper adjustment, there are basically only three malfunctions which can occur with the 1330 pilot. These, and the symptoms they can cause, are as follows:

1. **PILOT DIAPHRAGM RUPTURED:** Results in failure of the main valve to open. A ruptured pilot diaphragm will be evidenced by leakage through the vent hole in the pilot bonnet.
2. **PILOT SEAT DISC DETERIORATED:** Results in failure of the valve to seal off completely (pressure relief service). Can also cause poor pressure control.
3. **PILOT STEM BINDING:** Typically results in poor pressure control, though in extreme cases, it can result in failure of the main valve to open or close.

REPAIR PROCEDURES

Refer to the 1330 assembly drawing for parts identification.

A. DIAPHRAGM REPLACEMENT

1. Prior to disassembling the pilot, turn the adjusting screw (10) fully counterclockwise until it is loose enough to be turned with the fingers.
2. Remove the four bonnet capscrews (17).
3. Remove the bonnet (2). Set the spring (9) and spring retainers (11) aside in a safe place.
4. Pull the adapter (3) out of the pilot body (1).
5. Remove hex nut (16), lockwasher (22), upper diaphragm plate (8) and o'ring (20).
6. Remove old diaphragm (5).
7. Inspect both diaphragm plate o'rings (20). Replace if necessary.
8. Place new diaphragm on stem (7).
9. Replace upper diaphragm plate (8), o'ring (20), lockwasher (22) and hex nut (16). Tighten securely.
10. Insert adapter (2) back into pilot body (1).
11. Hold spring (9) and spring retainers (11) together in the proper orientation and insert them into the bonnet (2).
12. Place the bonnet over the adapter and insert the bonnet capscrews (17). Tighten securely.
13. Place valve back in service, following the startup and adjustment procedures given in the main portion of this manual.

B. SEAT DISC REPLACEMENT

1. Follow Steps 1 through 4 under DIAPHRAGM REPLACEMENT, above.
2. Remove capscrew (12), seal washer (13) and old seat disc (6).
3. Place new seat disc, new seal washer and capscrew (12) on stem. Tighten securely.
4. Reassemble pilot following Steps 10 through 13 under DIAPHRAGM REPLACEMENT, above.

C. STEM REPAIR

1. Follow Steps 1 and 2 under SEAT DISC REPLACEMENT, above.
2. Remove stem (7) from adapter (3).
3. Inspect stem and o'ring (21) carefully.
4. Remove any foreign material or light scratches from the stem with a fine grade of emery cloth. A badly scored stem should be replaced.
5. Replace o'ring (21).
6. Lubricate the o'ring and stem liberally with Vaseline® or similar lubricant.
7. Place stem in adapter (3). Make sure it moves freely.
8. Reassemble pilot following Steps 3 and 4 under SEAT DISC REPLACEMENT, above.

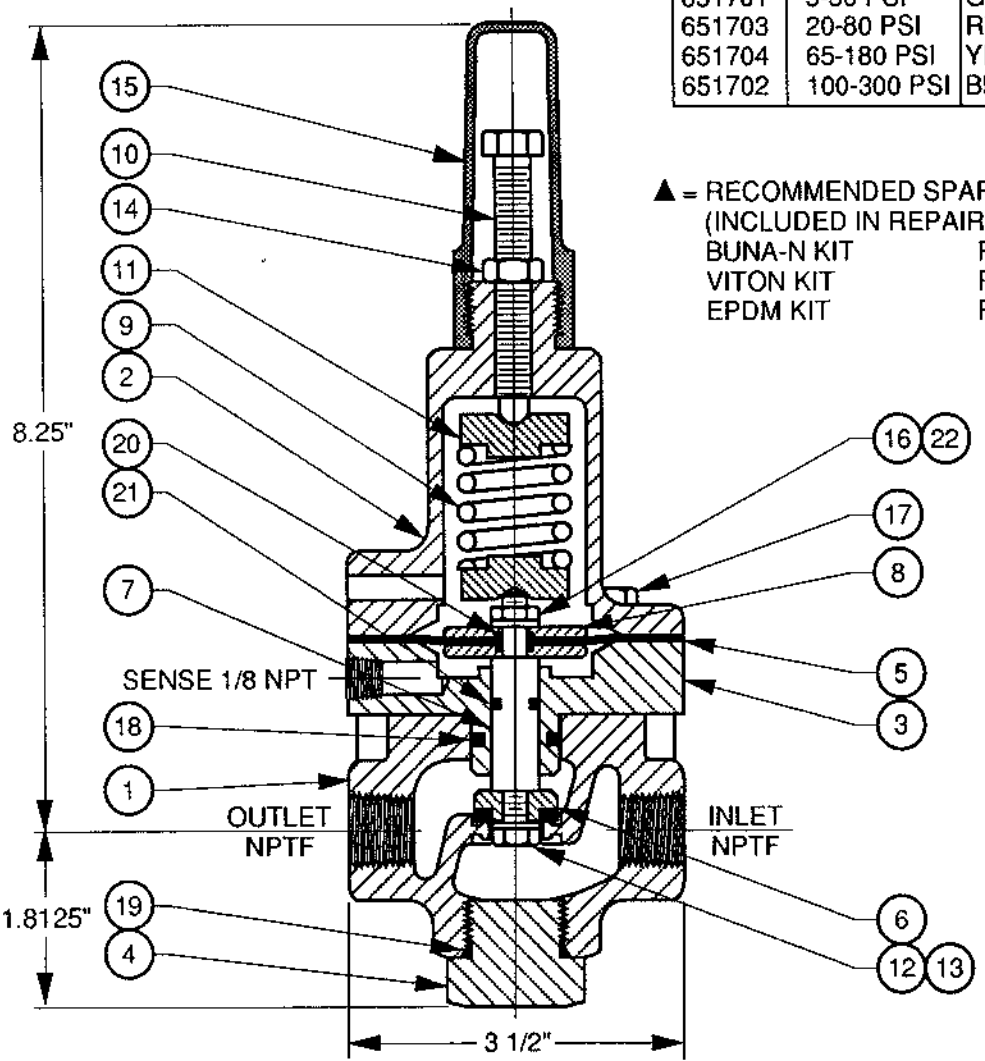

▲ = RECOMMENDED SPARE PARTS
(INCLUDED IN REPAIR KITS)

BUNA-N KIT	PN 930000
VITON KIT	PN 930100
EPDM KIT	PN 930400

ITEM	PART NO	QTY	DESCRIPTION	MATERIAL
1	302102	1	BODY	3/8" NPTF
	302104			1/2" NPTF
	302702			3/8" NPTF
	302704			1/2" NPTF
2	304102	1	BONNET	BRONZE
	304702			STN STEEL
3	300129	1	ADAPTOR	BRONZE
	300719			STN STEEL
4	692502	1	PLUG	ZINC PLTD STL
	310730			STN STEEL
5	694002	1	DIAPHRAGM	BUNA-N / NYLON
	694102			VITON / NYLON
	694016			EPDM / NYLON
6	310703	1	SEAT DISC	BUNA-N / SS
	310709			VITON / SS
	310707			EPDM / SS
7	314702	1	STEM	STN STEEL
	314002			MONEL
8	308102	2	DIAPHRAGM PLATE	BRASS
	308702			STN STEEL
9	CHART	1	SPRING	STN STEEL
10	300700	1	ADJUSTING SCREW	STN STEEL
11	300134	2	SPRING RETAINER	BRASS
	300729			STN STEEL
12	531700	1	HEX HEAD CAPSCREW	STN STEEL
13	685760	1	LOCKWASHER	STN STEEL
14	590717	1	HEX NUT	STN STEEL
15	692002	1	CAP	PVC
16	590712	1	HEX NUT	STN STEEL
17	531701	4	HEX HEAD CAPSCREW	STN STEEL
18	611116	1	O-RING	VITON
	614116			EPDM
19	610912	1	O-RING	BUNA-N
	611912			VITON
	914912			EPDM
20	611010	2	O-RING	VITON
	614010			EPDM
21	611012	1	O-RING	VITON
	614012			EPDM
22	685700	1	LOCKWASHER	STN STEEL

CHG	E.C. NO.	DATE	BY	REVISIONS	REF DWG NO'S

MATERIAL	TOLERANCES
NOTED	UNLESS NOTED FRACTIONAL ±1/64 DECIMAL ±.005 MACH. FINISH 125/ ANGULAR ±1/2°
NO. REQ'D	DRAWN BY RON
SCALE	DATE 2-14-96
1/2	CHKD. BY DATE

Control Valves TULSA, OKLAHOMA U.S.A.

MODEL 1330 PILOT 3/8"-1/2" NPTF
 PRESSURE RELIEF / SUSTAINING / SURGE

SIZE	DRAWING NUMBER	REV.
A	1330	

INSTALLATION & MAINTENANCE INSTRUCTIONS

2-WAY INTERNAL PILOT-OPERATED SOLENOID VALVES
NORMALLY CLOSED OPERATION
1/2" AND 3/4" NPT - 5/8" ORIFICE

ASCO

BULLETINS

8210

8211

Form No. V5827R1

DESCRIPTION

Bulletin 8210's are 2-way normally closed, internal pilot-operated solenoid valves, and are made of stainless steel. Standard valves have a General Purpose Type I Solenoid Enclosure.

Bulletin 8211's are the same as Bulletin 8210's except for the solenoid enclosure. Bulletin 8211's have a combination Watertight and Explosion-Proof Solenoid Enclosure designed to meet Enclosure Type 4-Watertight, Type 7 (C and D) Explosion-Proof Class I, Groups C and D and Type 9 (E, F & G) Dust Ignition-Proof Class II, Groups E, F and G. Installation and maintenance instructions for the watertight and explosion-proof solenoid enclosure are on Form No. V5380.

OPERATION

Normally Closed: Valve is closed when solenoid is de-energized; open when energized.

Manual Operator (Optional)

Valves with suffix "MO" in catalog number are provided with a manual operator which allows manual operation when desired or during an interruption of electrical power. To operate valve manually, rotate stem clockwise 180°. Disengage manual operator by rotating stem counterclockwise 180° before operating electrically.

INSTALLATION

Check nameplate for correct catalog number, pressure, voltage, frequency, and service.

Temperature Limitations

For maximum valve ambient and fluid temperatures, refer to chart below. Check catalog number prefix on nameplate to determine maximum temperatures.

CONSTRUCTION	COIL CLASS	CATALOG NUMBER PREFIX	MAXIMUM AMBIENT TEMP. °F	MAXIMUM FLUID TEMP. °F
AC Construction (Alternating Current)	F	NONE	77	175
DC Construction (Direct Current)	A, F or H	None, FT or HT	77	150

Positioning

This valve is designed to perform properly when mounted in any position. However, for optimum life and performance, the solenoid should be mounted vertically and upright to reduce the possibility of foreign matter accumulating in the solenoid base sub-assembly area.

Mounting

For mounting bracket (optional feature) mounting dimensions, refer to Figure 1.

Piping

Connect piping to valve according to markings on valve body. Apply pipe compound sparingly to male pipe threads only. If applied to valve threads, the compound may enter the valve and cause operational difficulty. Avoid pipe strain by properly supporting and aligning piping. When tightening the pipe, do not use valve or solenoid as a lever. Locate wrenches applied to valve body or piping as close as possible to connection point.

IMPORTANT: To protect the solenoid valve, install a strainer or filter, suitable for the service involved, in the inlet side as close to the valve as possible. Clean periodically depending on service conditions. See ASCO Bulletins 8600, 8601, and 8602 for strainers.

Wiring

Wiring must comply with local codes and the National Electrical Code. The solenoid housing has a 7/8" diameter hole to accommodate 1/2" conduit. On some constructions, a green grounding wire is provided. To facilitate wiring, the solenoid enclosure may be rotated 360° by removing the retaining cap or clip. **WARNING: When metal retaining clip disengages, it will spring upward.** Rotate enclosure to desired position. Then replace retaining cap or clip before operating.

Solenoid Temperature

Standard catalog valves are supplied with coils designed for continuous duty service. When the solenoid is energized for a long period, the solenoid enclosure becomes hot and can be touched by hand only for an instant. This is a safe operating temperature. Any excessive heating will be indicated by the smoke and odor of burning coil insulation.

MAINTENANCE

NOTE: It is not necessary to remove the valve from the pipeline for repairs.

WARNING: Turn off electrical power supply and depressurize valve before making repairs.

Cleaning

All solenoid valves should be cleaned periodically. The time between cleanings will vary depending on the medium and service conditions. In general, if the current to the coil is correct, sluggish valve operation, excessive noise or leakage will indicate that cleaning is required. Clean valve strainer or filter when cleaning the valve.

Preventive Maintenance

1. Keep the medium flowing through the valve as free from dirt and foreign material as possible.
2. While in service, the valve should be operated at least once a month to insure proper opening and closing.
3. Depending on the medium and service conditions, periodic inspection of internal valve parts for damage or excessive wear is recommended. Thoroughly clean all parts. Replace worn or damaged parts. However, for best results, replace all parts as supplied with an ASCO Rebuild Kit.

Causes Of Improper Operation

1. **Faulty Control Circuit:** Check the electrical system by energizing the solenoid. A metallic "click" signifies that the solenoid is operating. Absence of the "click" indicates loss of power supply. Check for loose or blown fuses, open-circuited or grounded coil, broken lead wires or splice connections.
2. **Burned-Out Coil:** Check for open-circuited coil. Replace coil if necessary. Check supply voltage; it must be the same as specified on nameplate.
3. **Low Voltage:** Check voltage across the coil leads. Voltage must be at least 85% of nameplate rating.
4. **Incorrect Pressure:** Check valve pressure. Pressure to valve must be within range specified on nameplate.
5. **Excessive Leakage:** Disassemble valve (see MAINTENANCE) and clean all parts. Replace worn or damaged parts. However, for best results, replace all parts as supplied with an ASCO Rebuild Kit.



Coil Replacement (Refer to Figure 2.)

WARNING: Turn off electrical power supply. Then proceed as follows:

1. Disconnect coil lead wires and green grounding wire if present.
2. Remove retaining cap or clip, nameplate, and housing.
WARNING: When metal retaining clip disengages, it will spring upward.
3. Remove spring washer, insulating washer, grounding wire terminal (if present), and coil from solenoid base sub-assembly. Insulating washers are omitted when a molded coil is used.
4. Reassemble in reverse order of disassembly. Use exploded view provided for identification and placement of parts.

CAUTION: The solenoid must be fully reassembled because the housing and internal parts complete the magnetic circuit. Place an insulating washer at each end of non-molded coil.

Valve Disassembly and Reassembly

NOTE: For valves with a manual operator (Suffix MO in catalog number) refer to Figure 3. For standard valves refer to Figure 2.

WARNING: Depressurize valve and turn off electrical power supply. Proceed in the following manner:

1. Remove retaining cap or clip and pull the entire solenoid enclosure off the solenoid base sub-assembly. **CAUTION:** When metal retaining clip disengages, it will spring upward.
2. Unscrew the solenoid base sub-assembly and remove bonnet gasket. For valves with a manual operator, unscrew manual operator body and remove stem retainer, manual operator stem sub-assembly, stem gasket, and bonnet gasket.
3. Remove bonnet screws (4), valve bonnet, core spring, core/diaphragm sub-assembly, and body gasket. **CAUTION:** Do not damage or distort hanger spring between core/diaphragm sub-assembly.
4. All parts are now accessible for cleaning or replacement. Replace worn or damaged parts. However, for best results, replace all parts as supplied with an ASCO Rebuild Kit.
5. Reassemble in reverse order of disassembly. Use exploded view provided for identification and placement of parts.
6. Replace body gasket and core/diaphragm sub-assembly, locating the bleed hole in the diaphragm assembly approximately 45° from the valve outlet.
7. Replace valve bonnet and bonnet screws (4). Torque bonnet screws (4) in a crisscross manner to 95 ± 10 inch-pounds (10,7 ± 1,1 newton-meters).
8. Insert core spring in core, wide end of core spring in core first, closed end protruding from top of core.
9. Replace bonnet gasket and solenoid base sub-assembly. Torque solenoid base sub-assembly to 175 ± 25 inch-pounds (19,8 ± 2,8 newton-meters).
10. For valves with a manual operator, replace stem gasket and manual operator stem sub-assembly in manual operator body.
11. Replace stem retainer on manual operator body. Be sure that the captive washer on manual operator stem sub-assembly is on the outside of the stem retainer when assembled.
12. Replace bonnet gasket, manual operator body, bonnet gasket, and solenoid base sub-assembly. Torque manual operator body and solenoid base sub-assembly to 175 ± 25 inch-pounds (19,8 ± 2,8 newton-meters).
13. Replace solenoid enclosure and retaining cap or clip.
14. Restore electrical power and line pressure.
15. After maintenance, operate the valve a few times to be sure of proper opening and closing.

ASCO REBUILD KITS

Rebuild Kits and Coils are available for ASCO valves. Parts marked with an asterisk (*) are supplied in Rebuild Kits.

ORDERING INFORMATION FOR ASCO REBUILD KITS

When Ordering Rebuild Kits or Coils, Specify Valve Catalog Number, Serial Number, Voltage, and Frequency.

PARTIAL VIEW OF MOUNTING BRACKET (OPTIONAL)

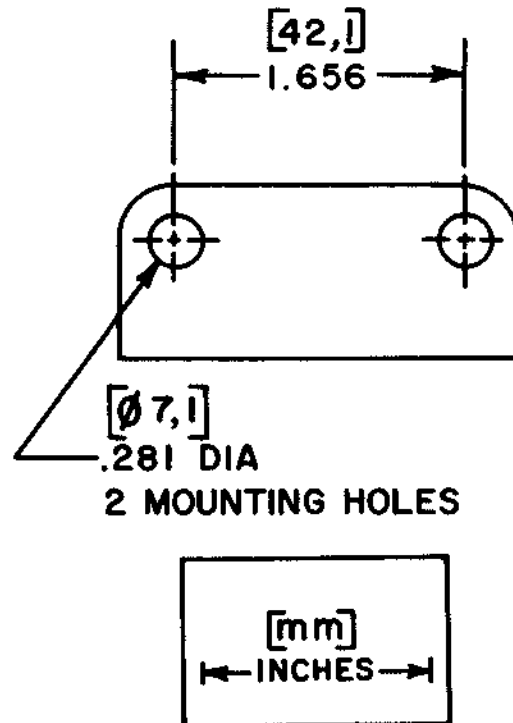

Figure 1.
Dimensions for Mounting Bracket
(Optional Feature)

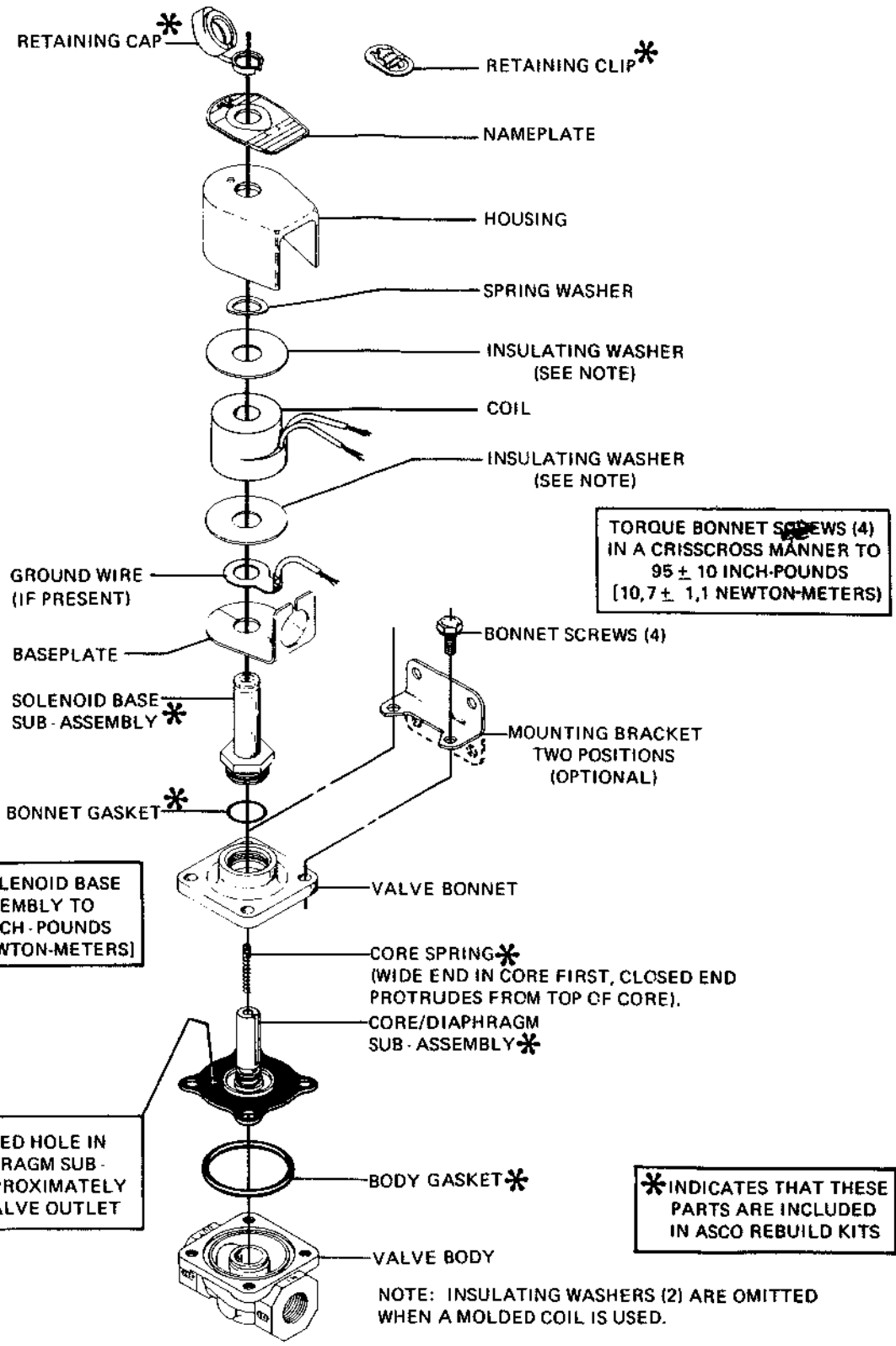

Figure 2. Bulletin 8210 - 1/2" and 3/4" NPT
General purpose solenoid enclosure shown.
For watertight and explosion-proof solenoid enclosure used on
Bulletin 8211, see Form No.V5380.

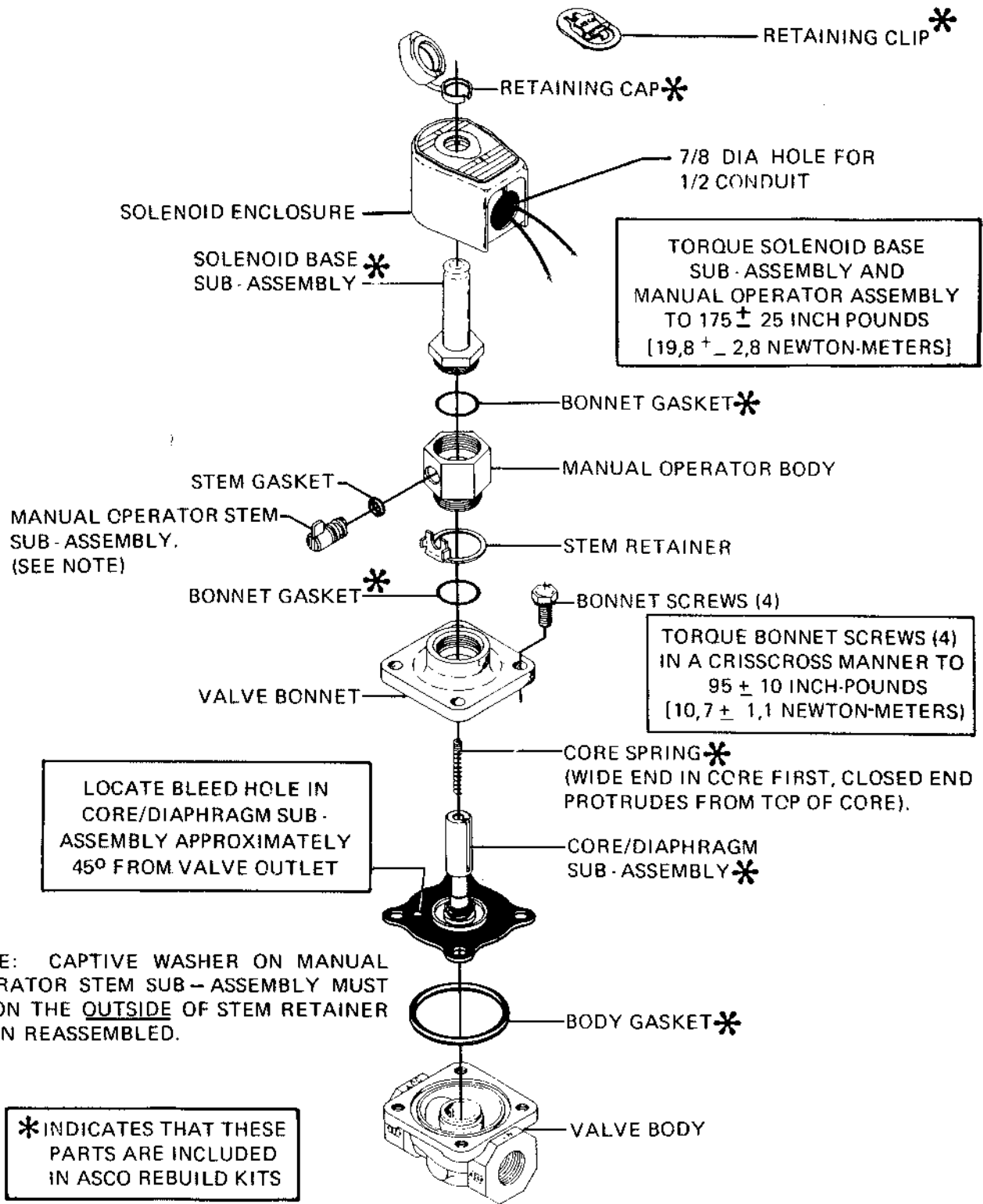

Figure 3. Bulletin 8210 - Manual Operator
 (Catalog No. with Suffix MO) General purpose solenoid enclosure shown.
 For watertight and explosion-proof solenoid enclosure used on
 Bulletin 8211, see Form No.V5380.

DESCRIPTION



MODEL 126 EJECTOR
 The Model 126 ejector is a simple tee fitting with a fixed orifice in its inlet port. It provides the proper supply pressure to the main valve diaphragm chamber, allowing various two-way control pilots to control the valve position.

MODEL 126 EJECTOR DIAGRAM

Brass Construction / Stainless Steel Construction

MATERIAL	PART NUMBER	P (NPT)	T-TUBE O.D.	STD. ORIFICE	USED ON VALVE SIZES
Brass	213100	3/8"	3/8"	.125"	1 1/4"-6"
Brass	214100	1/2"	1/2"	.188"	8"-10"
Brass	215100	3/4"	3/4"	.188"	12"-16"
316 Stn. Steel	213700	1/4"	3/8"	.090"	1 1/4"-6"
316 Stn. Steel	214700	3/8"	1/2"	.125"	8"-10"
316 Stn. Steel	215700	1/2"	3/4"	.188"	12"-16"

Orifice bushings are stainless steel.

STAINLESS

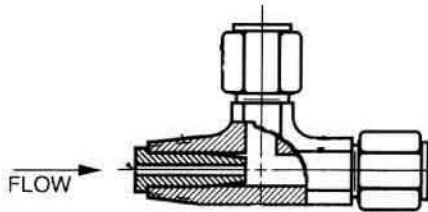

BRASS

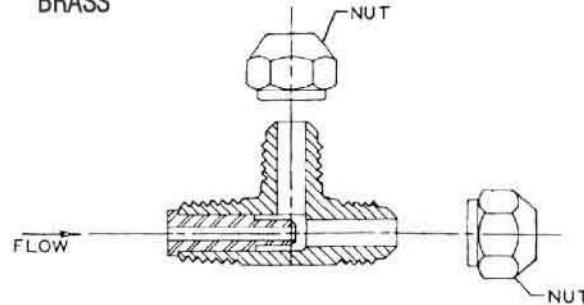

SCHEMATIC SYMBOL

The Model 126 Ejector is shown on OCV Valve Schematics as:

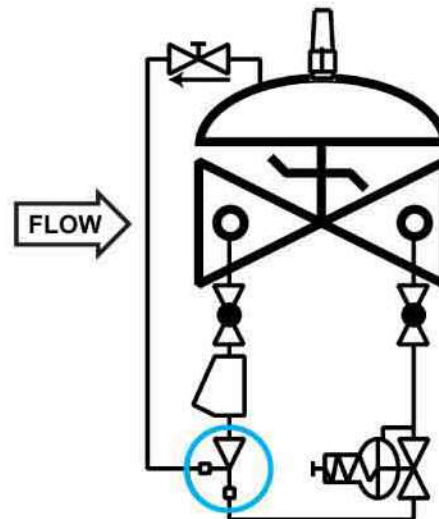
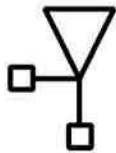

EXAMPLE: Shown here on a MODEL 127-3 Pressure Reducing Valve

DESCRIPTION



The Model 141-3 Flow Control Valve is an adjustable restriction device, installed in the control circuit tubing. The flow control valve differs from a standard needle valve in that it includes an internal check valve. Thus it allows free flow in one direction (through the check) and restricted flow in the other direction (through the needle). The setting of the flow control valve meters the flow into or out of the main valve diaphragm chamber,

thus controlling either the opening or closing speed of the main valve. These can be installed in series for separate opening and closing speed control. Restricted flow is in the direction of the flow arrow on the body.

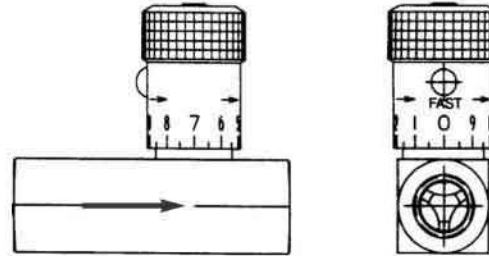

MODEL 141-3 MATRIX

MATERIAL	PART NUMBER	INLET/OUTLET (NPT)	A	USED ON VALVE SIZE*
Brass	682100	1/4	2 3/8	1 1/4"-2"
Brass	682101	3/8	2 3/4	2 1/2"-6"
Brass	682102	1/2	3 1/4	8"-10"
Brass	682103	3/4	3 7/8	12"-16"
Stn. Steel	682700	1/4	2 3/8	1 1/4"-2" Stn.
Stn. Steel	682701	3/8	2 3/4	2 1/2"-6"
Stn. Steel	682702	1/2	3 1/4	8"-10"
Stn. Steel	682703	3/4	3 5/8	12"-16"

Note: Flow control valve use and size may vary on valve application. Consult factory.

SCHEMATIC SYMBOL

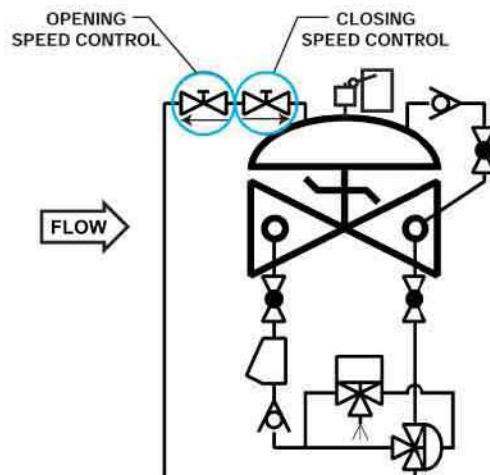

The Model 141-3 Flow Control Valve is shown on OCV Valve Schematics as:

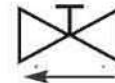

EXAMPLE: Shown here on a MODEL 125 Pump Control Valve as separate opening and closing speeds.

Flow Control Valves 141-3

DESCRIPTION

The Model 141-1 Check Valve uses a spring-loaded poppet that will allow flow in one direction only. It is the primary component used on valves with a reverse flow check function. Flow is in the direction of the arrow on the check valve body.



◀ Check Valves shown
Stainless Steel & Brass

**MODEL
141-1
MATRIX**

MATERIAL	PART NUMBER	INLET/OUTLET (NPT)	LENGTH	USED ON VALVE SIZE
Bronze	681100	3/8	2	1 1/4"-6"
Bronze	681101	1/2	2 1/8	8"-10"
Bronze	681102	3/4	2 1/4	12"-16"
Stn. Steel	681700	3/8	2 5/16	1 1/4"-6"
Stn. Steel	681701	1/2	2 5/16	8"-10"
Stn. Steel	681702	3/4	2 7/8	12"-16"

**SCHEMATIC
SYMBOL**

The Model 141-1 Check Valve is shown on OCV Valve Schematics as:

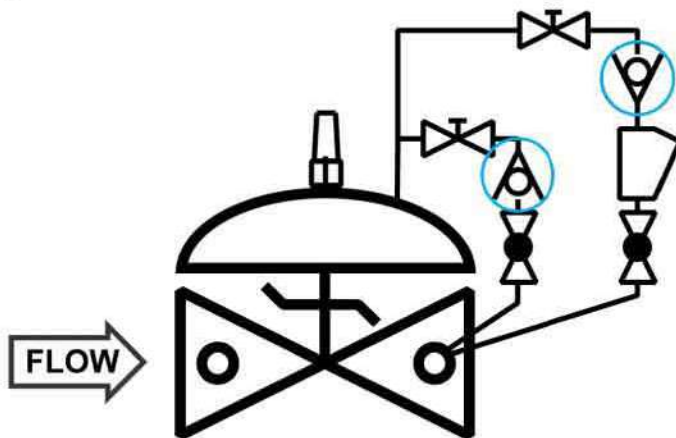
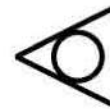

EXAMPLE: Shown here on a
MODEL 94-3 Check Valve.

Check Valve 141-1

DESCRIPTION

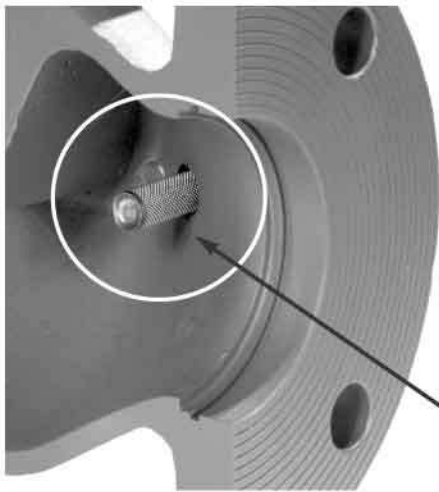

← Strainer Shown Installed

The 123 Inline Strainer installs in the inlet side port of the main valve, and protects the pilot system from solid contaminants in the line fluid. The screen prevents the entrance of particles into the pilot system piping while flow through the main valve washes the screen clean. Recommended use on petroleum valve applications where flushing or removal of the screen for cleaning is not practical or may be considered hazardous.

DIMENSIONS

PART NUMBER	A	B	C	D	E	USED ON VALVE SIZE
660704	3/8	1/4	11/16	2 3/16	1 1/2	1 1/4"-6"
660705	1/2	3/8	7/8	2 1/4	1 1/2	8"-10"
660706	3/4	1/2	1 1/8	2 3/8	1 1/2	12"-16"

MATERIALS

Inline strainers are all-stainless steel construction.

SCREEN SIZE

Standard screen is 40 mesh. Other mesh sizes are available.

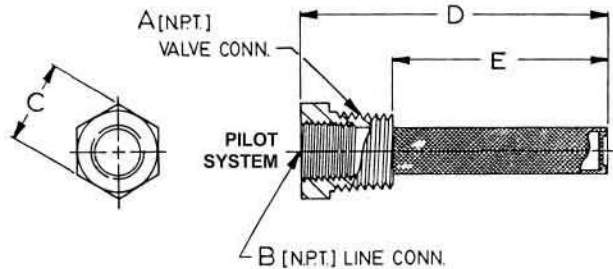

SCHEMATIC SYMBOL

The Model 123 Inline Strainer is shown on OCV Valve Schematics as:

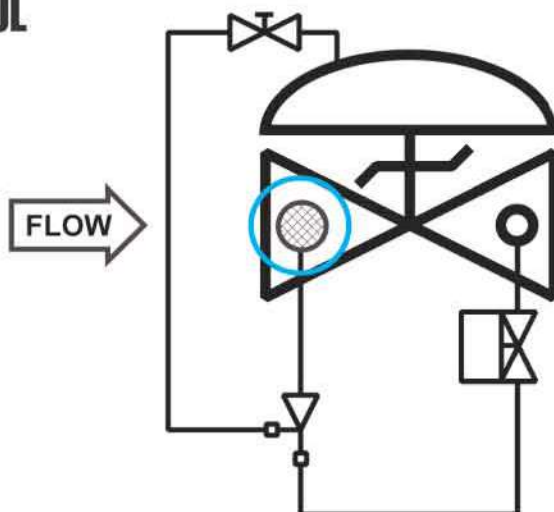

EXAMPLE: Shown here on a MODEL 115-2 Solenoid Valve.