

# installation, operating and maintenance instructions

## fire pump relief valve

# model 108FC

Rev. 3-12-03

### GENERAL DESCRIPTION

The OCV Model 108FC is specifically designed for use on the discharge of a fire pump. It will relieve any pressure higher than its set point and thereby can ensure a constant pressure in the system as demand changes.

The 108FC is **UL Listed and FM Approved** for this service as follows:

- A. UL-Listed for both horizontal split case centrifugal and vertical turbine fire pumps, at up to 300 psi in sizes 3"-6", and up to 175 psi in size 8".
- B. FM Approved for both horizontal split case centrifugal and vertical turbine fire pumps, at up to 175 psi in sizes 3"-8".

The 108FC consists of the following components, arranged as shown on the schematic diagram:

1. **Model 65 Basic Control Valve**, a hydraulically-operated, diaphragm-actuated, globe or angle valve which closes with an elastomer-on-metal seal.
2. **Model 1330FC Pressure Relief Pilot**, a two-way, normally-closed pilot valve which senses upstream pressure under its diaphragm and balances it against an adjustable spring load. An increase in upstream pressure tends to make the pilot open.
3. **Model 126 Ejector**, a simple "tee" fitting with a fixed orifice in its inlet port. It provides the proper pressure to the diaphragm chamber of the main valve depending on the position of the pressure relief pilot.
4. **Model 141-1 Check Valve**, which prevents the 108FC from inadvertently opening when used

on vertical turbine pumps.

5. **Model 159 Y-Strainer**, which protects the pilot system from solid contaminants in the line fluid.
6. A bonnet-mounted **Pressure Gauge**, useful for monitoring valve operation.

At user option, the 108FC may also be equipped with the following:

1. Model 155 Visual Indicator (Item 7).
2. Model 141-3 Closing Speed Control (UL-listed valves only).
3. Model 141-1 Isolation Ball Valves (UL-listed valves only).

### THEORY OF OPERATION

To understand how the 108FC operates, it is best to start with the **Ejector (3)**. Due to the orifice in its upstream port, the ejector creates a pressure drop proportional to the flow through it. The flow through the ejector is in turn controlled by the degree of opening of the **Pressure Relief Pilot (2)**. The **wider the pilot opens, the greater the flow** through the ejector and the **lower the pressure** downstream of the orifice. Conversely, the **more the pilot closes, the lower the flow** through the ejector and the **greater the pressure** downstream of the orifice.

Now note that the diaphragm chamber of the Main Valve (1) is connected to the branch port of the ejector and is thus downstream of the orifice. Therefore, the pressure in the diaphragm chamber of the main valve is effectively controlled by the pressure relief pilot, in the manner described above. As the pilot **opens**, the diaphragm pressure **decreases** and the main valve **opens**; as the pilot **closes**, the diaphragm

pressure **increases** and the main valve **closes**.

Since the 108FC is used as a **pressure relief valve**, the pressure upstream of the main valve is normally below the set point of the relief pilot. Therefore, the pilot is fully closed and so is the main valve. However, if for any reason, the pressure rises above the set point, the pilot will open and the main valve will follow in turn. The net effect is that the main valve will open and control the pressure at the set point, not allowing it to rise any further. Once pressure returns to normal, the pilot and main valve will return to the closed position.

## INSTALLATION

Figure 1 shows a typical installation of an angle pattern 108FC (Model 108FCA) in pressure service. This illustration is intended only as a rough guide for valve installation, as any fire pump installation is subject to approval by the local fire marshal or other approving agency.

Notice the use of an isolation valve immediately upstream 108FC. While this does not affect the operation of the valve, it can be extremely useful if the valve needs to be isolated from the line for maintenance or repair.

For full installation details, the user is referred to the Model 65 Basic Valve section of this manual.

## START-UP AND ADJUSTMENTS

The following procedures should be followed in the order presented in order to affect an initial startup of the 108FC.

**NOTE: UL Listed Model 108FC valves 3" thru 6" have an adjustment range of 60-175 psi when supplied with a 150# inlet flange. When supplied with a 300# inlet flange, the adjustment range is 100-300 psi. All UL Listed 8" valves have an adjustment range of 60-175 psi regardless of inlet flange rating. All FM Approved valves have an adjustment range of 60-180 psi regardless of size or flange rating.**

1. Install a pressure gauge of the proper range upstream of the 108FC. The unused inlet side port in the main valve body may be used for this purpose if there is no convenient location in the upstream piping.
2. Remove the plastic cap from the pressure relief pilot (2) and loosen the adjusting screw jam nut.

Turn the adjusting screw **clockwise** to a full stop.

3. Start the pump or otherwise start the system flowing. The main valve at this time should be fully closed.
4. Carefully loosen a pipe plug in the main valve bonnet until fluid begins to discharge around the threads. When only clear fluid (no air) is discharging, retighten the plug.
5. While observing the inlet pressure gauge, retard flow in the system by closing valves or otherwise reducing demand until the pressure increases to approximately 5 psi **above** the desired set point.
6. Slowly turn the adjusting screw of the pressure relief pilot (2) **counterclockwise** until the valve opens and the pressure falls **to the set point**. Tighten the adjusting screw jam nut and replace the plastic cap.
7. Increase flow in the system or otherwise increase demand until pressure returns to normal. The valve should close.
8. Repeat step 5 for set point verification. The valve should reopen. Repeat step 7.
9. Shut down the pump.

## MAINTENANCE

Because of the simplicity of design of the 108FC, required maintenance is minimal. However, the following checks, periodically performed, can do much to keep the valve operating properly and efficiently.

1. Check for chipped or peeling paint. Touch up as required.
2. Check for leaks at fittings and around flanges and connections. Tighten as required.
3. Check the screen of the Y-strainer for buildup of solid material. Clean as required. This point is most important, as a clogged strainer can keep the valve from closing. On new installations, it is recommended that the strainer be checked every day or two until experience dictates a greater or lesser interval. Strainer maintenance is covered in detail on a special page later in this manual.

## TROUBLESHOOTING

In the event of malfunction of the 108FC, the following guide should enable the technician to isolate the specific cause of the problem and take the appropriate

ate corrective action.

**A. MAIN VALVE FAILS TO OPEN:**

1. Valve closed upstream or downstream of the 108FC. Open as required.
2. Pressure relief pilot (2) adjusted too far clockwise. See Adjustment instructions.
3. Diaphragm of pressure relief pilot (2) ruptured. This will be evidenced by a discharge of fluid from the vent hole in the pilot bonnet. Replace diaphragm. See the 1330FC Pilot section of this manual.
4. Stem of pressure relief pilot (2) binding. Disassemble pilot and determine cause. See the 1330FC Pilot section of this manual.
5. Stem of main valve binding. Disassemble valve and determine cause. See the Model 65 Basic Valve section of this manual.

**B. MAIN VALVE FAILS TO CLOSE:**

1. Strainer (5) clogged. Clean as required.
2. Pressure relief pilot (2) adjusted too far counterclockwise. See Adjustment instructions.
3. Pressure relief pilot (2) stem binding or seat badly deteriorated. Disassemble pilot and determine cause. See the 1330FC Pilot section of this manual.
4. Main valve diaphragm ruptured. Replace diaphragm. See the Model 65 Basic Valve section of this manual.
5. Main valve stem binding or object caught in valve. Disassemble valve and determine cause. See the Model 65 Basic Valve section of this manual.

**C. MAIN VALVE OPENS AND CLOSES, BUT LEAKS WHEN CLOSED.**

1. Pressure relief pilot (2) adjusted slightly too low. See Adjustment instructions.
2. Damaged seat in the pressure relief pilot (2). Replace seat. See the 1330FC pilot section of this manual.
3. Damaged seat in the main valve. Replace seat. See the Model 65 Basic Valve section of this manual.

# MODEL 108FCA

## FIRE PUMP RELIEF VALVE

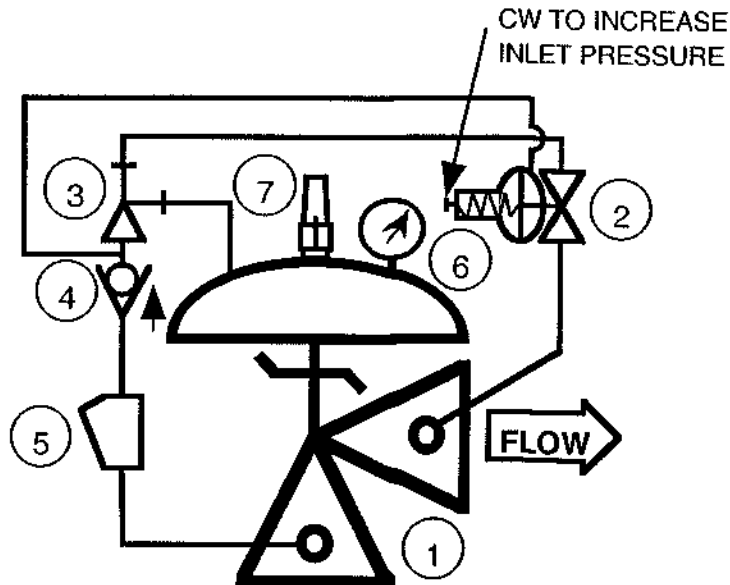

60-175 PSI ADJUSTMENT RANGE - UL & FM (3" THRU 8")

60-300 PSI ADJUSTMENT RANGE - UL (3" THRU 6")

ITEM	PART NO.	QTY	DESCRIPTION
1	65A	1	BASIC ANGLE VALVE ASSEMBLY
2	1330FC	1	PRESSURE RELIEF PILOT
3	126	1	EJECTOR
4	141-1	1	CHECK VALVE
5	159	1	Y-STRAINER
6	589004	1	PRESSURE GAUGE
7	155	1	VISUAL INDICATOR (Optional)

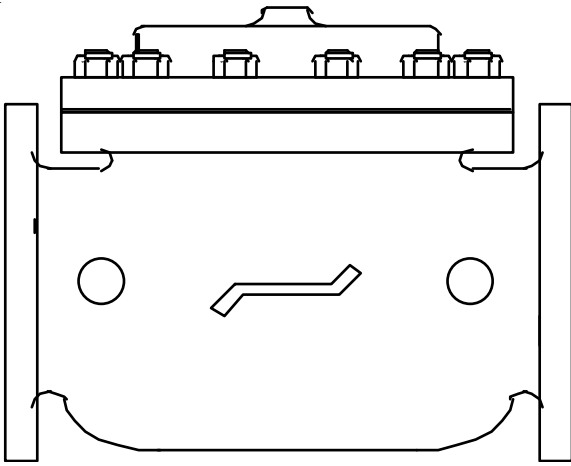

# installation, operating, and maintenance instructions

## series 65 basic control valve

### GENERAL DESCRIPTION

The OCV Series 65 is a hydraulically-operated, diaphragm-actuated valve. It is available in either a globe (Model 65) or angle (Model 65A) configuration. The diaphragm is nylon-fabric bonded with synthetic rubber and forms a sealed chamber in the upper portion of the valve, separating operating pressure from line pressure. An elastomeric seat disc forms a tight seal with the valve seat when pressure is applied above the diaphragm.

### FUNCTIONAL DESCRIPTION

Because the Series 65 is a hydraulically operated valve, it requires a minimum line pressure of approximately 5 psig in order to function. The valve functions on a simple principle of pressure differential. The line pressure at the inlet of the valve is bypassed through the pilot control piping to the diaphragm chamber of the valve. This pressure, together with the valve spring, works against the pressure under the valve seat. Because the effective area of the diaphragm is greater than that of the seat, the valve is held tightly closed. As the controlling pilot(s) allow the pressure to bleed off the diaphragm chamber, the two opposing pressures begin to balance and the valve will begin to open. The valve can be used to perform a simple on-off function, or with the proper pilot system, a modulating, or regulating function.

In cases where the line fluid is unusually dirty, or is otherwise unsuitable for operating the valve, an independent operating pressure source may be employed. The pressure available from such a source must be equal to, or greater than, line pressure.

### INSTALLATION

In order to insure safe, accurate and efficient operation of the OCV control valve, the following list of checkpoints and procedures should be followed when installing the

valve.

1. Make a careful visual inspection of the valve to insure that there has been no damage to the external piping, fittings or controls. Check that all fittings are tight.
2. Thoroughly flush all interconnecting piping of chips, scale and foreign matter prior to mounting the valve.
3. Install the valve in the line according to the flow arrow on the inlet flange. The arrow should point downstream.
4. Allow sufficient room around the valve for ease of adjustment and maintenance service.

In addition, it is highly recommended that:

1. Isolation valves (eg., gate or butterfly) be installed on the inlet and discharge sides of the valve to facilitate isolating the valve for maintenance.
2. Pressure gauges be installed at the inlet and outlet sides of the valve to provide monitoring of the valve during initial start-up and during operation. The body side ports, if unused by the pilot system, provide a convenient connection for the gauges.
3. All valves larger than 6" be installed horizontally, i.e., with the bonnet pointed up, for ease of adjustment and maintenance servicing.

### MAINTENANCE

The OCV control valve requires no lubrication and a minimum of maintenance. However, a periodic inspection should be established to determine how the fluid being handled is affecting the efficiency of the valve. In a water system, for example, the fluid velocity as well as the substances occurring in natural waters, such as dissolved minerals and suspended particles, vary in every installation. The effect of these actions or substances must be determined by inspection. It is recommended that an annual inspection, which includes ex-

amination of the valve interior, be conducted. Particular attention should be paid to the elastomeric parts, i.e., the diaphragm and seat disc. Any obviously worn parts should be replaced.

### REPAIR PROCEDURES

In the event of malfunction of the OCV control valve, troubleshooting should be conducted according to the procedures outlined for the specific model of valve. Then, if those steps indicate a problem with the main valve, this section will outline the procedures necessary to correct the problem.

Problems with the main valve can be classed in three basic categories:

1. VALVE FAILS TO OPEN
  - a. Diaphragm damaged\* - See Procedure A
  - b. Stem binding - See Procedure B
2. VALVE FAILS TO CLOSE
  - a. Diaphragm damaged\* - See Procedure A
  - b. Stem binding - See Procedure B
  - c. Object lodged in valve - See Procedure B
3. VALVE OPENS AND CLOSES BUT LEAKS WHEN CLOSED
  - a. Seat disc damaged - See Procedure C
  - b. Seat ring damaged - See Procedure D

\*A diaphragm failure can prevent the valve from either opening or closing, depending on the flow direction. Most water service valves flow "under the seat", in which case a diaphragm failure will keep the valve from closing. On the other hand, most fuel service valves flow "over the seat", in which case a diaphragm failure will keep the valve from opening. To determine which you have, examine the bridge mark cast into the side of the valve body, then compare it with the figures below.

#### PROCEDURE A : DIAPHRAGM REPLACEMENT

1. Isolate the valve from the system by closing upstream and downstream block valves.
2. Loosen one of the tubing connections on the bonnet. Allow any residual pressure to bleed off.
3. Remove all tubing connected at the bonnet.
4. Remove the bonnet nuts.
5. Remove the bonnet. If the bonnet sticks in place, it may be loosened by rapping sharply around its edge with a rubber-headed mallet. *NOTE: 8" and larger valves are equipped with eye bolts through which a chain can be fastened to aid in*

*lifting the bonnet.*

6. Remove the spring.
7. Remove the diaphragm plate capscrews and the diaphragm plate.
8. Remove the old diaphragm.
9. Making sure the dowel pin holes are in the proper location, place the new diaphragm over the studs and press down until it is flat against the body and spool.
10. Replace the diaphragm plate and the diaphragm plate capscrews.
11. Tighten all diaphragm plate capscrews snugly.
12. Replace the spring.
13. Replace the bonnet and reinstall the bonnet nuts.
14. Tighten the bonnet nuts snugly using a criss-cross tightening pattern.
15. Reinstall the control tubing.
16. Reopen the upstream and downstream block valves.
17. Before placing the valve back in service, perform the air bleed procedure described in the first section of this manual.

#### PROCEDURE B: CORRECTION OF BINDING STEM

1. Perform Steps 1 thru 6 of Procedure A, above.
2. Remove the spool assembly from the valve. *NOTE:*

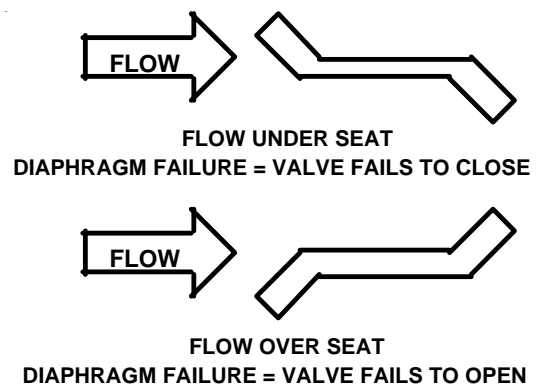

*On smaller valves, this can be accomplished simply by grasping the stem and pulling upward. Valves 6" and larger have the top of the stem threaded to accept an eyebolt to aid in lifting the spool out of the body. 6" thru 12" valves are threaded 3/8-16. 14" and 16" valves are threaded 5/8-11.*

3. Carefully examine both ends of the stem for deep scratches, scoring or buildup of mineral deposits.

Polish the stem if necessary using a fine grade of emery cloth.

4. Similarly, examine and polish the upper bushing (in the bonnet) and the lower guide (in the seat ring).
5. Reinstall the spool assembly.
6. Reassemble the valve, following Steps 12 thru 17 in Procedure A.

**PROCEDURE C: SEAT DISC REPLACEMENT**

1. Perform Steps 1 and 2 of Procedure B, above.
2. With the spool assembly removed from the body, remove the seat retainer screws.
3. Slide the seat retainer off the lower end of the stem.
4. Remove the seat disc from its groove in the spool.  
*NOTE: The seat disc may fit quite tightly in the groove. If necessary, it may be pried out using a thin-bladed screwdriver or similar tool.*
5. Install the new seat disc in the groove.
6. Reinstall the seat retainer and tighten the seat retainer screws.
7. Reassemble the valve, following Steps 5 and 6 of Procedure B.

**PROCEDURE D: SEAT RING REPLACEMENT**

*NOTE: It is rare for a seat ring to require replacement. Minor nicks and scratches in the seating surface can usually be smoothed out with emery cloth.*

1. Perform Steps 1 and 2 of Procedure B, above.
2. If you are working on a 4" or smaller valve, follow Steps 3 thru 9, below.
3. If you are working on a 6" or larger valve, follow Steps 10 thru 16, below.

4. Seat rings in valves 4" and smaller are threaded into the valve body. To remove, you will need a special seat ring tool. You may fabricate one using standard pipe as shown in the sketch below, or one may be purchased from OCV.
5. Using the seat ring tool, unthread the seat ring from the body.
6. Remove the old o-ring from the counterbore in the body.
7. Install the new o-ring in the counterbore.
8. Using the seat ring tool, install the new seat ring.
9. Reassemble the valve, following Steps 5 & 6 of Procedure B.
10. Seat rings in valves 6" and larger are bolted into the body with socket head capscrews. In addition you will note that the seat ring is equipped with additional threaded holes that may be used for "jacking" the seat ring out of the body.
11. Remove the socket head capscrews.
12. Remove the old seat ring from the body by temporarily installing two or more of the capscrews in the "jacking" holes.
13. Install a new o-ring in the groove of the new seat ring. Lubricate the o-ring and outer seat ring wall with Vaseline® or similar lubricant.
14. Install the new seat ring in the body, making sure that the capscrew holes line up.
15. Replace and tighten all the capscrews.
16. Reassemble the valve, following Steps 5 and 6 of Procedure B.

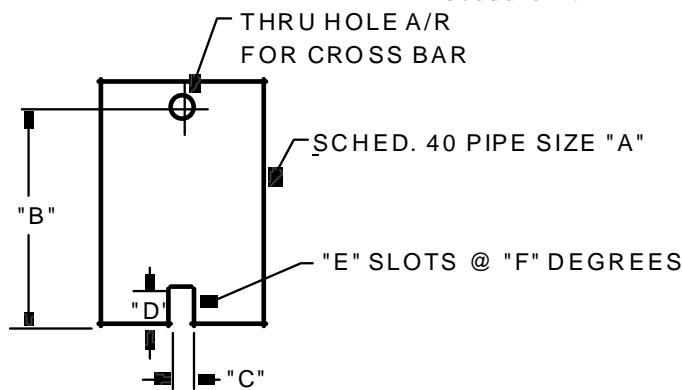

VALVE SIZE	"A" PIPE SIZE	"B" MIN. LENGTH	"C" SLOT WIDTH	"D" SLOT DEPTH	"E" NO. OF SLOTS	"F" SLOT SPACING
1-1/4"	3/4"	6"	3/8"	3/8"	2	180°
1-1/2"	3/4"	6"	3/8"	3/8"	2	180°
2"	1-1/2"	7"	3/8"	3/8"	2	180°
2-1/2"	2"	8"	1/2"	1/2"	3	120°
3"	2-1/2"	9"	5/8"	5/8"	2	180°
4"	3"	10"	5/8"	5/8"	2	180°

REVISED 3-17-97



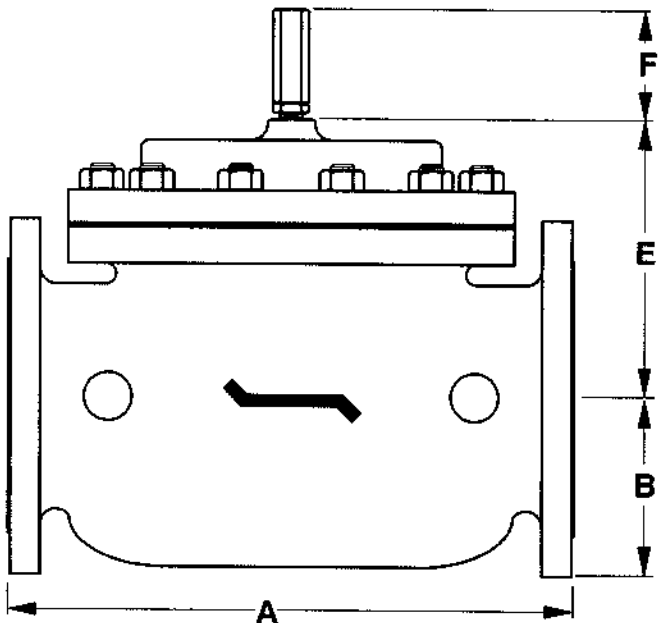
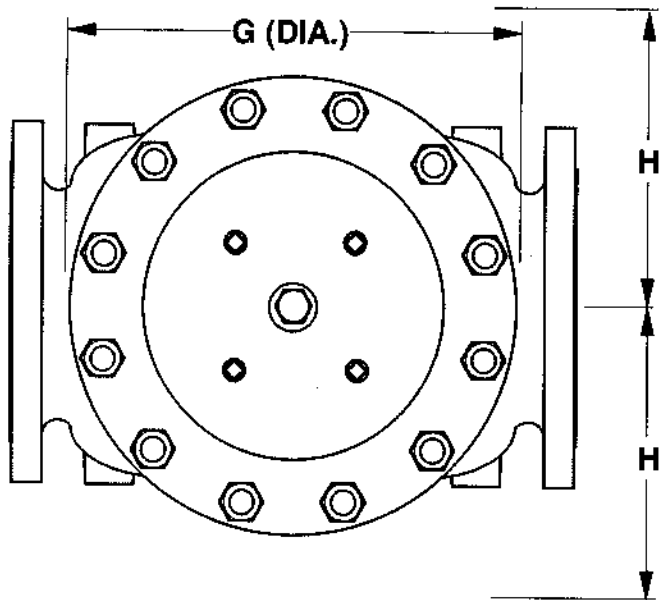

REV. A SDJ 6-6-02  
REV. B SDJ 2-3-03

DIM	ANSI CLASS	VALVE SIZE												
		1 1/4	1 1/2	2	2 1/2	3	4	6	8	10	12	14	16	24
A	SE	8.75	8.75	9.88	10.50	13.00	-	-	-	-	-	-	-	-
	150	8.50	8.50	9.38	10.50	12.00	15.00	17.75	25.38	29.75	34.00	39.00	40.38	62.00
	300	8.75	8.75	9.88	11.12	12.75	15.62	18.62	26.38	31.12	35.50	40.50	42.00	63.75
B	SE	1.44	1.44	1.69	1.88	2.25	-	-	-	-	-	-	-	-
	150	2.31	2.50	3.00	3.50	3.75	4.50	5.50	6.75	8.00	9.50	10.62	11.75	16.00
	300	2.62	3.06	3.25	3.75	4.12	5.00	6.25	7.50	8.75	10.25	11.50	12.75	18.00
C	SE	4.38	4.38	4.75	6.00	6.50	-	-	-	-	-	-	-	-
	150	4.25	4.25	4.75	6.00	6.00	7.50	10.00	12.69	14.88	17.00	-	20.81	-
	300	4 3/8	4.38	5.00	6.38	6.38	7.81	10.50	13.19	15.56	17.75	-	21.62	-
D	SE	3.12	3.12	3.88	4.00	4.50	-	-	-	-	-	-	-	-
	150	3.00	3.00	3.88	4.00	4.00	5.50	6.00	8.00	11.38	11.00	-	15.69	-
	300	3.25	3.25	4.12	4.38	4.38	5.81	6.50	8.50	12.06	11.75	-	16.50	-
E	ALL	6.00	6.00	6.00	7.00	6.50	7.92	10.00	11.88	15.38	17.00	18.00	19.00	27.00
F	ALL	3.88	3.88	3.88	3.88	3.88	3.88	3.88	6.38	6.38	6.38	6.38	6.38	8.00
G	ALL	6.00	6.00	6.75	7.69	8.75	11.75	14.00	21.00	24.50	28.00	31.25	34.50	52.00
H	ALL	10.00	10.00	11.00	11.00	11.00	12.00	13.00	14.00	17.00	18.00	20.00	20.00	28.50

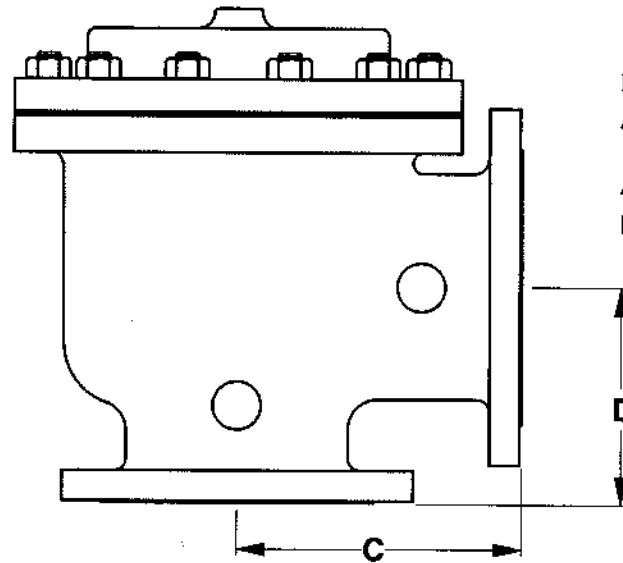

NOTE: 3" VALVE DIMENSIONS ARE FOR NEW MODEL 3100

4" VALVE DIMENSIONS ARE FOR NEW MODEL 4400

<b>TOLERANCES</b>		 <b>OCV Control Valves</b> TULSA, OKLAHOMA U.S.A.		
UNLESS NOTED FRACTIONAL $\pm 1/64$ DECIMAL $\pm .005$ MACH. FINISH 125/ ANGULAR $\pm 1/2^\circ$				
<b>GENERAL VALVE DIMENSIONS</b>				
DRAWN BY SDJ	DATE 10-6-97	SIZE <b>A</b>	DRAWING NUMBER <b>65D</b>	REV. <b>B</b>
CHKD. BY	DATE			



# installation, operating, and maintenance instructions

## pressure sustaining/ pressure relief pilot

### model 1330FC

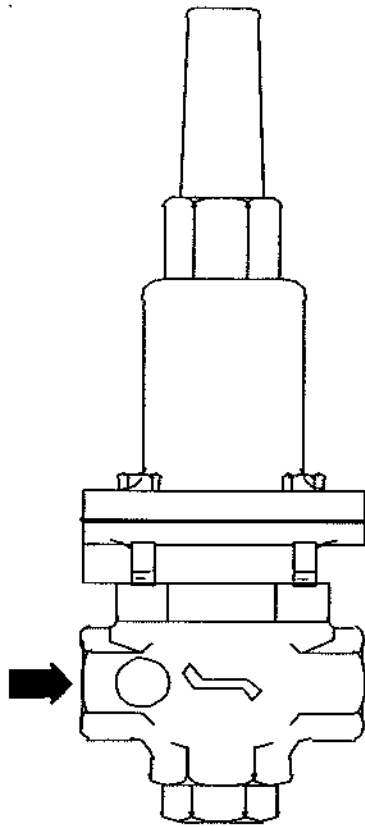

#### GENERAL DESCRIPTION

The Model 1330FC Pressure Sustaining Pilot is a normally-closed, direct-acting, spring-loaded, diaphragm-type control pilot. It is designed to maintain a constant preset inlet pressure on the Main valve. It is manually adjustable by means of an adjustment screw located under the cap on top of the pilot. It is a constant throttling device, maintaining precise, positive control of the Main valve. It may also be used for open and close pressure relief service.

#### FUNCTIONAL DESCRIPTION

Basically, the Model 1330FC Pressure Sustaining Pilot controls the amount of pressure in the upper chamber of the Main valve(s). (Hence, the degree of opening or closing of the Main valve). The upstream pressure increases, the pilot begins to open, decreasing the amount of pressure in the upper chamber of the main valve allowing it to open a proportionate amount, in order to maintain a constant inlet pressure. As the upstream pressure decreases, the pilot begins to close, allowing the pressure in the upper chamber of the main valve to increase causing it to close. This is a constant modulating action compensating for any change in upstream pressure.

#### INSTALLATION AND ADJUSTMENT

The model 1330FC Pressure Sustaining Pilot should be installed in the Main Valve Control Piping between the

ejector and the downstream body tap. Flow should be in the direction indicated on the pilot body. A sensing line (1/4" O.D. Tubing) should be installed from the pilot sensing port and point upstream of the valve. Pilot adjustment is achieved with the adjustment located on top of the bonnet. Increase upstream pressure by turning the screw clockwise; decrease upstream pressure by turning screw counterclockwise.

#### MAINTENANCE

Because of the simplicity of design of the 1330FC Pilot, required maintenance is minimal. Fittings and bolts should be periodically checked, and the body should be inspected for damage or excessive buildup of foreign material.

#### TROUBLESHOOTING

Troubleshooting the 1330FC Pilot is equally simple. Major troubleshooting points are as follows:

1. A ruptured pilot diaphragm is readily evident by the discharge of fluid at the vent hole in the pilot bonnet.
2. An indication of the pilot stem binding may be checked by removing the pilot bonnet and moving the stem by hand. If excessive drag is evident, disassemble the pilot and determine the cause.
3. A suspected leak in the pilot seat area can be checked by disassembling the pilot and inspecting the seat's disc and the seat in the pilot's body.

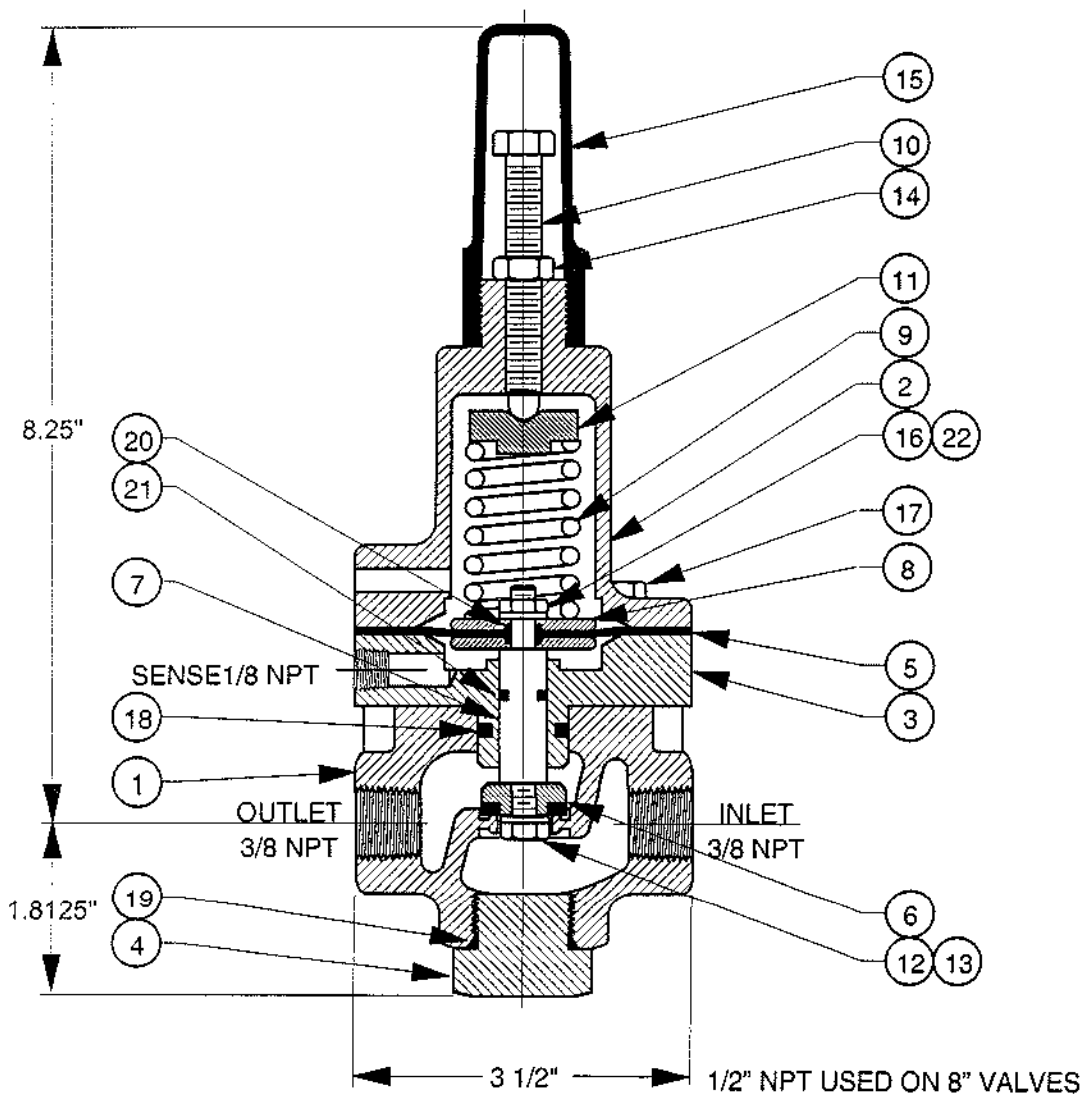

▲ = RECOMMENDED SPARE PARTS  
 (INCLUDED IN REPAIR KIT PN 930000)  
 1/2" NPT AVAILABLE  
 STN STL CONSTRUCTION AVAILABLE

NOTE:  
 100-300 PSI SPRING PN 651702 TO BE USED WITH (2) PN 300134  
 SPRING RETAINERS IN LIEU OF (1) PN 300134 SPRING RETAINER.

ITEM	PART NO.	QTY	DESCRIPTION	MATERIAL
▲ 22	685700	1	LOCKWASHER	STN. STEEL
▲ 21	611012	1	O-RING	VITON
▲ 20	611010	2	O-RING	VITON
▲ 19	610912	1	O-RING	BUNA-N
▲ 18	611116	1	O-RING	VITON
17	531701	4	HEX HD CAPSCREW	STN. STEEL
16	590712	1	HEX NUT	STN. STEEL
15	692002	1	CAP	PVC
14	590717	1	HEX NUT	STN. STEEL
▲ 13	685760	1	LOCKWASHER	STN. STEEL
12	531700	1	HEX HD CAPSCREW	STN. STEEL
11	300140	1	SPRING RETAINER	BRASS
10	300700	1	ADJUSTING SCREW	STN. STEEL
9	651000	1	SPRING (60-180 PSI)	STEEL
8	308102	2	DIAPHRAGM PLATE	BRASS
7	314702	1	STEM	STN. STEEL
▲ 6	310703	1	SEAT DISC	BUNA-N/SS
▲ 5	694002	1	DIAPHRAGM	BUNA-N/NYLON
4	692502	1	PLUG	ZINC PLTD STL
3	300129	1	ADAPTER	BRONZE
2	304102	1	BONNET	BRONZE
1	302102	1	BODY	BRONZE

CHG	E.C. NO.	DATE	BY	REVISIONS	REF DWG NO'S

MATERIAL	TOLERANCES
BRONZE / BUNA-N	N/A
NO. REQ'D	DRAWN BY RON
SCALE 1/2	DATE 11-6-95
	CHKD. BY 
	DATE 

**Control Valves** TULSA, OKLAHOMA U.S.A.

**PILOT, 1330FC 3/8 NPT BRONZE / BUNA-N  
 PRESSURE RELIEF**

SIZE	DRAWING NUMBER	REV.
<b>A</b>	<b>230111</b>	

**DESCRIPTION**



**MODEL 126 EJECTOR**  
 The Model 126 ejector is a simple tee fitting with a fixed orifice in its inlet port. It provides the proper supply pressure to the main valve diaphragm chamber, allowing various two-way control pilots to control the valve position.

**MODEL 126 EJECTOR DIAGRAM**

Brass Construction / Stainless Steel Construction

MATERIAL	PART NUMBER	P (NPT)	T-TUBE O.D.	STD. ORIFICE	USED ON VALVE SIZES
Brass	213100	3/8"	3/8"	.125"	1 1/4"-6"
Brass	214100	1/2"	1/2"	.188"	8"-10"
Brass	215100	3/4"	3/4"	.188"	12"-16"
316 Stn. Steel	213700	1/4"	3/8"	.090"	1 1/4"-6"
316 Stn. Steel	214700	3/8"	1/2"	.125"	8"-10"
316 Stn. Steel	215700	1/2"	3/4"	.188"	12"-16"

Orifice bushings are stainless steel.

STAINLESS

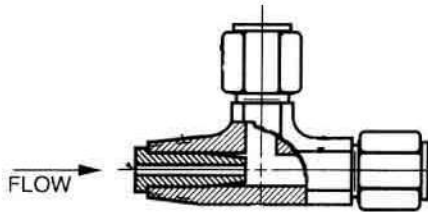

BRASS

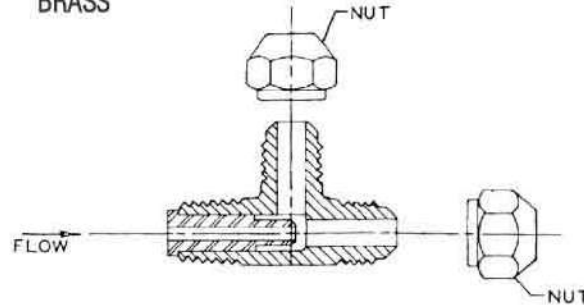

**SCHEMATIC SYMBOL**

The Model 126 Ejector is shown on OCV Valve Schematics as:

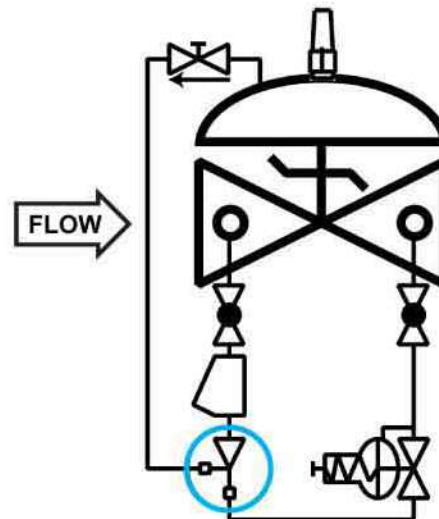
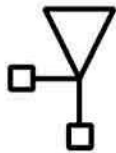

EXAMPLE: Shown here on a MODEL 127-3 Pressure Reducing Valve

**DESCRIPTION**

The Model 141-1 Check Valve uses a spring-loaded poppet that will allow flow in one direction only. It is the primary component used on valves with a reverse flow check function. Flow is in the direction of the arrow on the check valve body.



◀ Check Valves shown  
Stainless Steel & Brass

**MODEL  
141-1  
MATRIX**

MATERIAL	PART NUMBER	INLET/OUTLET (NPT)	LENGTH	USED ON VALVE SIZE
Bronze	681100	3/8	2	1 1/4"-6"
Bronze	681101	1/2	2 1/8	8"-10"
Bronze	681102	3/4	2 1/4	12"-16"
Stn. Steel	681700	3/8	2 5/16	1 1/4"-6"
Stn. Steel	681701	1/2	2 5/16	8"-10"
Stn. Steel	681702	3/4	2 7/8	12"-16"

**SCHEMATIC  
SYMBOL**

The Model 141-1 Check Valve is shown on OCV Valve Schematics as:

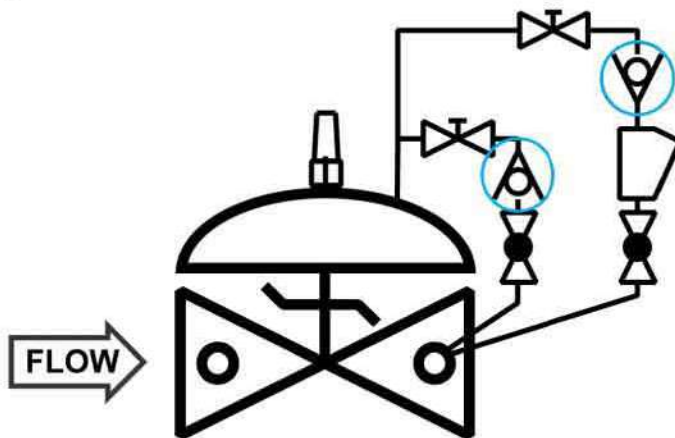
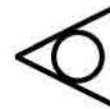

EXAMPLE: Shown here on a  
MODEL 94-3 Check Valve.

**Check Valve 141-1**





**DESCRIPTION**

**MODEL 159 Y-STRAINER**  
 The 159 Y-Strainer installs in the inlet piping of the pilot system and protects the pilot system from solid contaminants in the line fluid. It is the standard strainer for water service valves.

**MODEL 159 Y-STRAINER MATRIX**

MATERIAL	PART NUMBER	INLET/OUTLET (NPT)	BLOW OFF PORT (NP)	A	STD. MESH	USED ON VALVE SIZE
Bronze	660100	3/8	3/8	2 11/16	24	1 1/4"-6"
Bronze	660101	1/2	3/8	2 5/8	24	8"-10"
Bronze	660102	3/4	3/8	3 5/16	24	12"-16"
Stn. Steel	660700	3/8	1/4	2 1/2	20	1 1/4"-6"
Stn. Steel	660701	1/2	1/4	2 1/2	20	8"-10"
Stn. Steel	660702	3/4	1/4	3 1/8	20	12"-16"

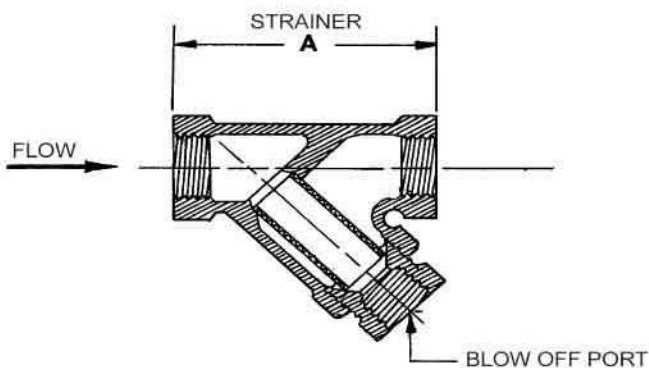

**MATERIALS**

Bronze, ASTM B62  
 Optional mesh sizes: 50, 100  
 Stainless Steel, CF8-M (316)  
 Optional mesh sizes: 60, 80, 100  
 Screens are stainless steel

**SCHEMATIC SYMBOL**

The Model 159 Y-Strainer is shown on OCV Valve Schematics as:

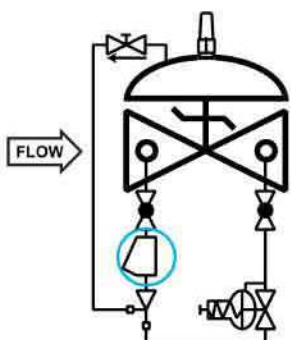

EXAMPLE: Shown here on a MODEL 127-3 Pressure Reducing Valve

**MAINTENANCE**

Routine cleaning and checking of the Y-Strainer will aid in keeping the control valve functioning properly. Pilot system isolation ball valves are supplied on valves equipped with the Model 159 Y-Strainer. These allow flushing of the screen through the blow off port, or removal of the screen itself for manual cleaning.

**DESCRIPTION**

The Model 155 Visual Indicator is a device that enables the user to determine the extent of opening of a control valve. It consists of an adaptor threaded into the center port of the valve bonnet, a rod threaded into the main valve stem, a sealing O-ring, and a protective clear plastic housing. The indicator rod moves as the valve opens and closes. It may be installed on virtually any OCV control valve, and can be done so without any disassembly of the valve itself.

**WHERE USED** - Standard on Series 94 Check Valves, Series 3330 Altitude Valves, and Series 22 Digital Control Valves. Optional on any other valve not employing a limit switch or position transmitter.



**MODEL 155 MATRIX**

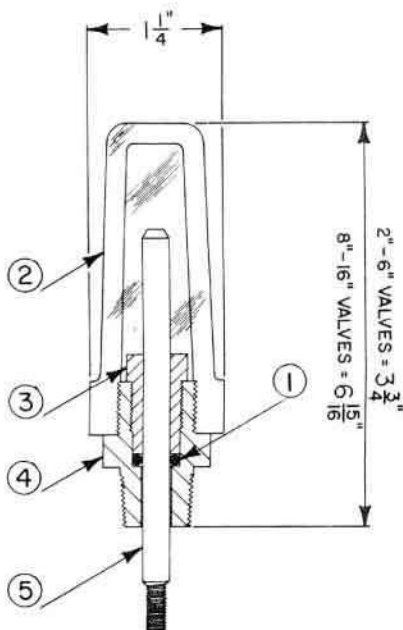

MATERIAL	PART NO. (BRASS ADAPTOR)	PART NO. (STAINLESS ADAPTOR)	VALVE TRAVEL (FULL STROKE)
1 1/4" - 1 1/2"	255100	255700	3/8"
2"	255100	255700	1/2"
2 1/2"	255100	255700	3/4"
3"	255100	255700	1"
4"	255101	255701	1 3/8"
6"	255102	255702	1 1/2"
8" - 10"	255103	255703	2 1/2"
12"	255104	255704	3"
14" - 16"	255105	255705	3 1/2", 4"
24"	255109	255709	6"

ITEM	DESCRIPTION
1	O-Ring
2	Housing
3	Bushing
4	Adaptor
5	Stem

**SCHEMATIC SYMBOL**

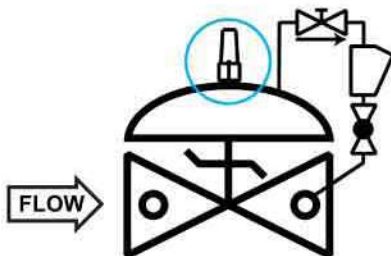

The Model 155 is shown on OCV Valve Schematic as:



EXAMPLE: Shown here on a Model 94-1 Check Valve

**MATERIALS**

- Indicator Rod: Monel
- Adapter: Brass (std.), Stainless Steel (optional)
- Housing: Butyrate (1 1/4" - 6") Acrylic (8" and larger)
- O-Ring: Viton® (std.) Buna-N, EPDM (optional)

**Valve Position Indicator 155**

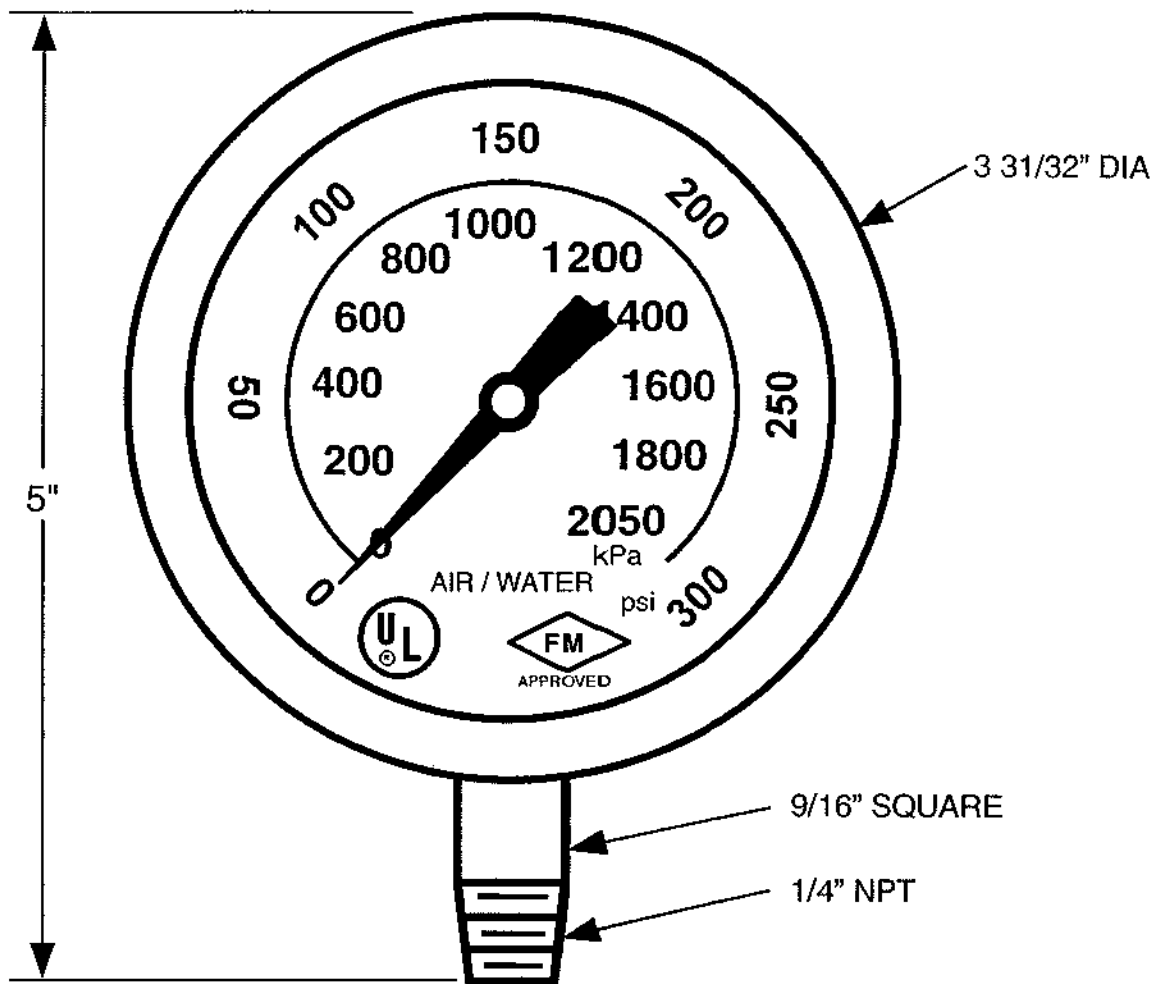

**PRESSURE GAUGE FOR FIRE PROTECTION SERVICE**

APPROVALS: UL / FM  
 RANGE: 0-300 PSI, 0-2050 kPa  
 SIZE: 3.5"  
 CASE: STAINLESS STEEL  
 RING: STAINLESS STEEL, POLISHED  
 WINDOW: GLASS, DOUBLE STRENGTH  
 DIAL: BRASS, WHITE COATED  
 POINTER: BRASS  
 MOVEMENT: BRASS WITH SS PINION, UNDERLOAD AND OVERLOAD STOPS  
 SYSTEM: BRASS SOCKET, TUBE AND TIP  
 ACCURACY: 3-2-3%

				<b>MATERIAL</b>	<b>TOLERANCES</b>	 <b>Control Valves</b> TULSA, OKLAHOMA U.S.A. <b>UL / FM PRESSURE GAUGE</b> <b>0-300 PSI</b>			
				NOTED	GENERAL ENVELOPE				
				NO. REQ'D	DRAWN BY RON	DATE 8-24-00	SIZE	DRAWING NUMBER	REV.
CHG	E.C. NO.	DATE	BY	SCALE NONE	CHKD. BY	DATE	<b>A</b>	<b>589004</b>	
<b>REVISIONS</b>									



## ANGLE VALVE FLOW CHART

BASED ON WATER AT 60°F

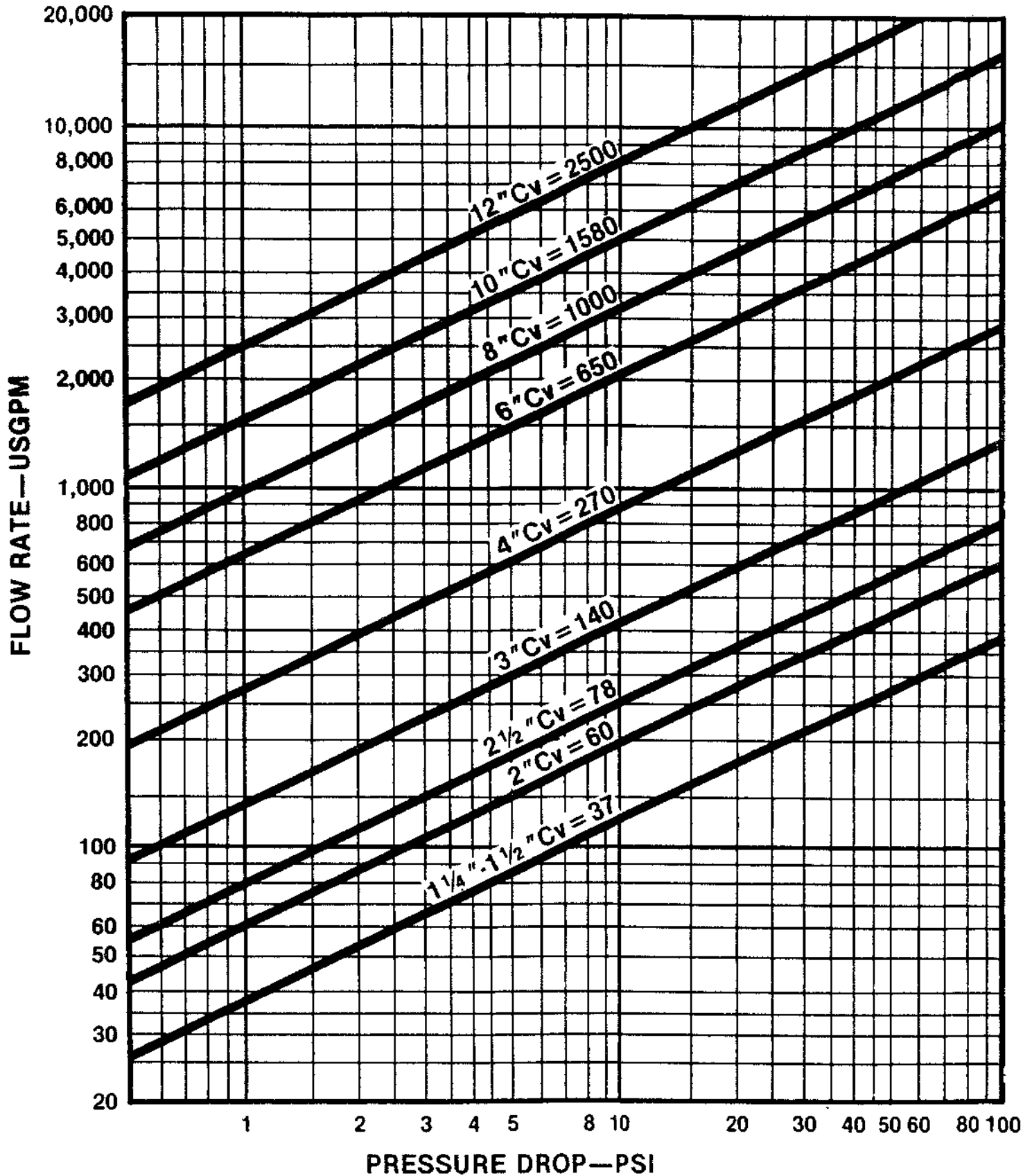

Cv = Number of Gallons (water) that will flow at ONE psi pressure differential

# GLOBE VALVE FLOW CHART

BASED ON WATER AT 60°F

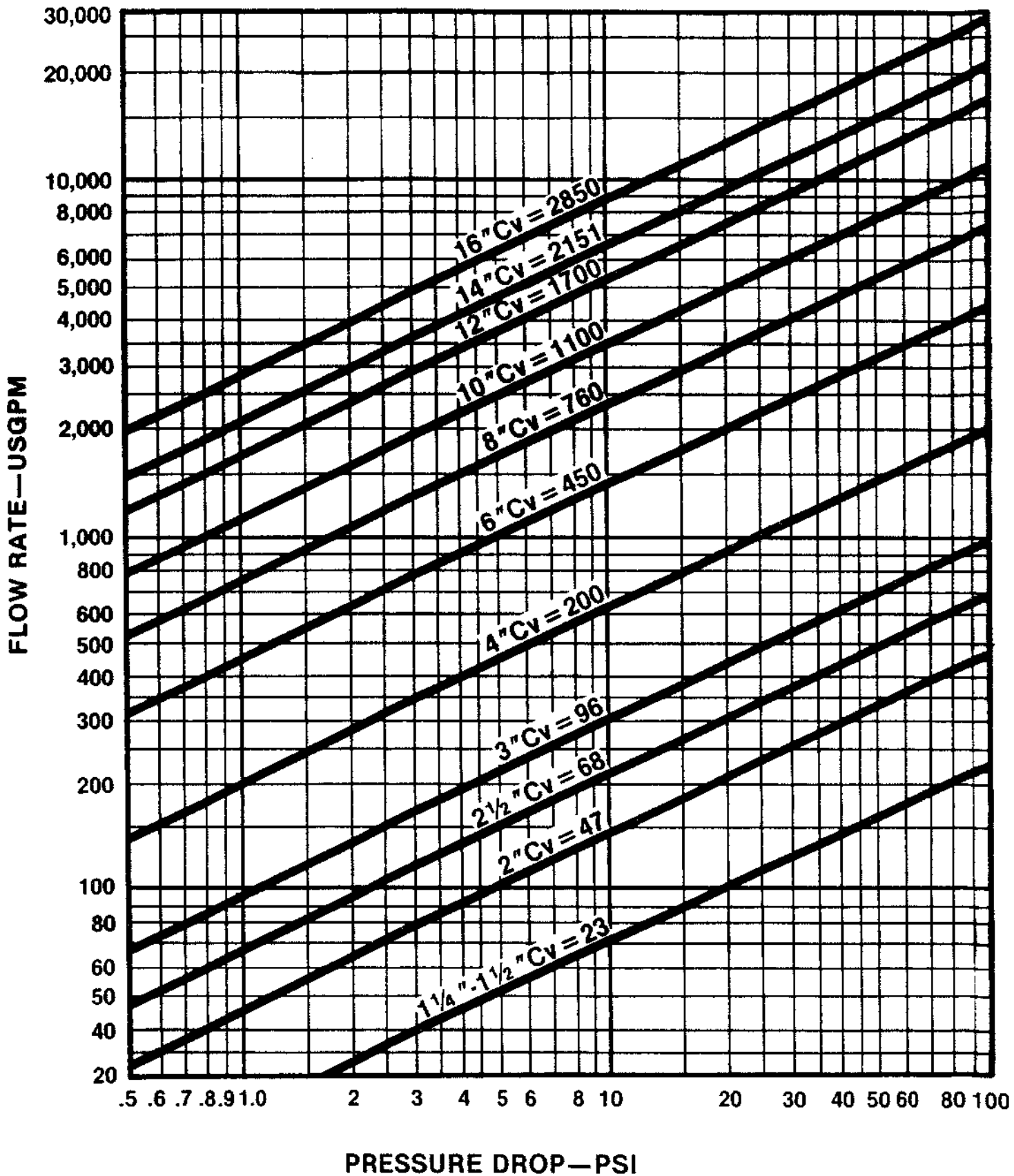

Cv = Number of Gallons (water) that will flow at ONE psi pressure difference