

installation, operating, and maintenance instructions

digital preset valve

model 115-3

revised 6-12-00

GENERAL DESCRIPTION

The OCV Model 115-3 is designed to open, close and control flow rate based on electrical signals received from the preset controller (Smith Accu-load or similar device.)

The 115-3 consists of the following components:

1. **Model 65 Basic Control Valve**, a hydraulically-operated, diaphragm-actuated, globe valve which closes with an elastomer-on-metal seal.
2. **Model 450 Two-Way, Normally-Open Solenoid Pilot**, which acts to close the valve.
3. **Model 451 Two-Way, Normally-Closed Solenoid Pilot**, which acts to open the valve.
4. **Two Model 141-2 Needle Valves**. Installed in series with both solenoid pilots. Acts as opening and closing speed controls.
5. **Model 123 Inline Strainer**, which serves to protect the pilot system from solid contaminants in the line fluid.

At user option, the Model 115-3 may also be equipped with:

1. **Two Model 141-4 Ball Valves**. Serve to isolate all or various parts of the pilot system for maintenance or troubleshooting.
2. **Model 155 Visual Indicator**.
3. **Model 150 Limit Switch Assembly**. For remote indication of valve position.

THEORY OF OPERATION

First, it is important to understand the basic principles of operation of the diaphragm-actuated control valve. The main valve contains two "chambers", separated and sealed from each other by the flexible diaphragm. The lower chamber contains the flow passages of the valve. The forces that exist in this chamber are (1) valve inlet pressure, acting under the diaphragm, and (2) the difference between valve inlet and outlet pressures, acting across the valve seat. The upper chamber, hereinafter called the diaphragm chamber, is connected to the pilot system, which can pressurize the chamber to the inlet pressure, to outlet pressure or anywhere in between. It is the balance of forces between the two chambers which determines what the valve does.

If the pilot system applies full inlet pressure to the diaphragm chamber, there is no force acting across the diaphragm, leaving only the differential across the seat, which fully closes the valve.

If the pilot system reduces the pressure on the diaphragm chamber to outlet pressure, the same differential will exist across the diaphragm as exists across the seat. However, because the effective diaphragm area is greater than the seat area, the valve will be driven open.

Finally, if the pilot system applies an intermediate pressure (between inlet and outlet) to the diaphragm chamber, the valve will hold a position between full open and full closed. With this in mind, refer to the schematic diagram, and let's see how the valve works to control pressure.

Assume that it is desired to open the valve or increase the flow rate. The preset controller energizes both solenoids, releasing pressure from the diaphragm chamber to the outlet side. As described above, the main valve opens further, increasing the flow. Once the controller is "satisfied", it deenergizes solenoid (3) only. This pilot closes, the diaphragm chamber is hydraulically "locked", and the valve maintains its new position.

Conversely, assume that it is desired to close the valve or decrease the flow rate. The controller deenergizes solenoid pilot (2), opening this pilot. This increases pressure on the diaphragm chamber from the inlet side. As described above, the main valve closes further, decreasing the flow rate. Once the controller is "satisfied", it again energizes and closes solenoid pilot (2). The diaphragm chamber is again hydraulically "locked", and the valve maintains its new position.

INSTALLATION

The 115-3 is furnished fully factory assembled and ready for installation at the appropriate point in the system. The user is referred to the Series 65 Basic Valve section of this manual for full installation details.

Following mechanical installation, the two solenoid pilots are wired to the controller.

STARTUP

1. Prior to starting the pump, make sure any isolation valves in the main line are open, i.e., that flow can be allowed.
2. Start pump. The main valve should close.
3. Carefully loosen a pipe plug in the main valve bonnet until fluid appears around the threads. When only clear fluid (no air) is discharging, retighten the plug.
4. Energize solenoid 2 and 3. The valve should open. With the valve partially open, deenergize solenoid 3. The valve should hold its position.
5. Deenergize solenoid 2. The valve should close. With the valve partially open, energize solenoid 2. The valve should hold its position.
6. Again, deenergize solenoid 2. The valve should close fully.
7. The valve may now be placed in normal operation.

MAINTENANCE

Due to the simplicity of the 115-3 and its pilot system, required maintenance is minimal.

1. Periodically check for leaks at fittings and around flanges and connections. Tighten as required.
2. Periodically check that all electrical connections are secure.
3. It is recommended that the main valve and pilot diaphragms and seats be checked for signs of wear or deterioration after the first year of operation. Unless service conditions are unusually severe, a diaphragm/seat life of 3-5 years can be expected.

TROUBLESHOOTING

In the event of malfunction of the 115-3, the following guide should enable the technician to isolate the cause of the problem.

A. MAIN VALVE FAILS TO OPEN

1. Make sure main line isolation valves are open.
2. Check for voltage at coil of solenoid 3.
 - (a) If no voltage is present, the problem is in the controller.
 - (b) If proper voltage is present, proceed to Step 3.
3. Check for voltage at coil of solenoid 2.
 - (a) If no voltage is present, problem is in the controller.
 - (b) If voltage is present, proceed to Step 4.
4. Coil of solenoid 3 burned out or stuck closed. See SOLENOID VALVE section of this manual.
5. Coil of solenoid 2 burned out, or seat is damaged. See SOLENOID VALVE section of this manual.
6. Main valve stem binding or diaphragm ruptured. See SERIES 65 of this manual.

B. MAIN VALVE FAILS TO CLOSE

1. Check for voltage at coil of solenoid 3.
 - (a) If voltage is present, problem is in the controller.
 - (b) If no voltage is present, proceed to Step 2.
2. Check for voltage at coil of solenoid 2.
 - (a) If voltage is present, problem is in the controller.
 - (b) If no voltage is present, proceed to Step 3.

3. Solenoid Pilot 3: Stuck open or seat damaged. See SOLENOID VALVE section of this manual.
4. Solenoid Pilot 2: Stuck closed. See SOLENOID VALVE section of this manual.
5. Clogged strainer. Clean as required.
6. Main valve stem binding or object in valve. See SERIES 65 section of this manual.

C. MAIN VALVE OPENS AND CLOSES BUT WILL NOT MAINTAIN "HOLD" POSITION.

1. If valve drifts closed, refer to Steps 3 and 5 under MAIN VALVE FAILS TO OPEN.
2. If valve drifts open, refer to Step 3 under MAIN VALVE FAILS TO CLOSE.

MODEL 115-3

SOLENOID CONTROL VALVE DIGITAL THROTTLING TYPE (Fuel Service)

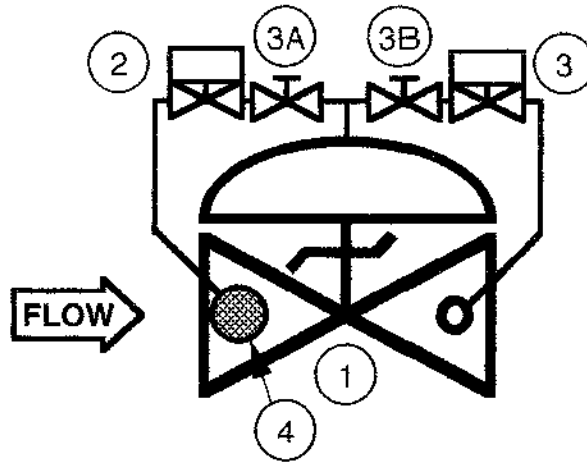

OPERATION

SOLENOID 2	SOLENOID 3	MAIN VALVE 1
ENERGIZED	ENERGIZED	OPENS
ENERGIZED	DE-ENERGIZED	HOLDS
DE-ENERGIZED	DE-ENERGIZED	CLOSES

ITEM	PART NO.	QTY	DESCRIPTION
1	65	1	BASIC VALVE ASSEMBLY (Fail Closed)
2	450	1	TWO-WAY SOLENOID PILOT, N.O.
3	451	1	TWO-WAY SOLENOID PILOT, N.C.
4	123	1	INLINE STRAINER
5	--	1	J-BOX (Optional - Not Shown)

MODEL 115-3

RON
3-8-00

SOLENOID CONTROL VALVE DIGITAL THROTTLING TYPE WITH LIMIT SWITCH (Fuel Service)

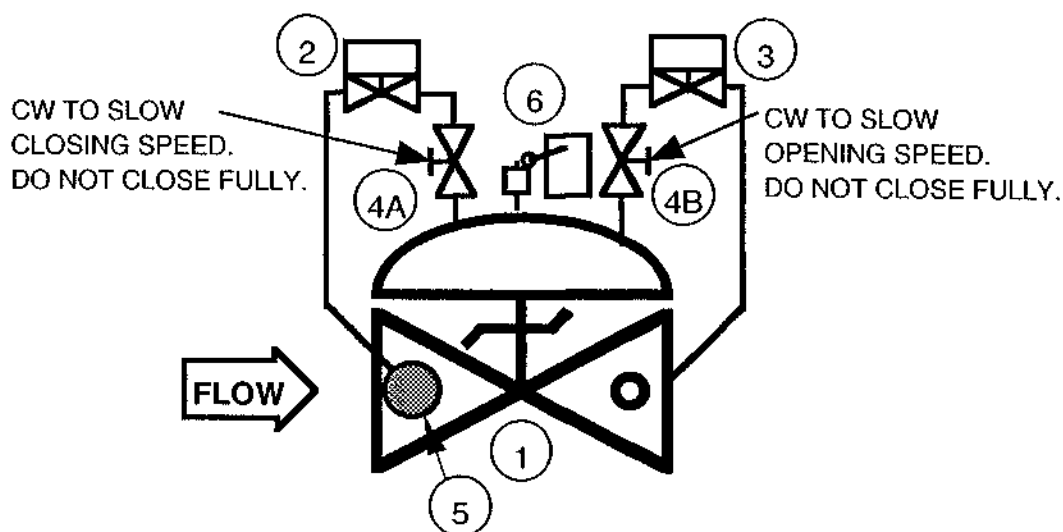

OPERATION:

SOL. 2	SOL. 3	VALVE
ENERGIZED	ENERGIZED	OPENS
DEENERGIZED	DEENERGIZED	CLOSES
ENERGIZED	DEENERGIZED	HOLDS POS.

ITEM	PART NO.	QTY	DESCRIPTION
1	65	1	BASIC VALVE ASSEMBLY (Fail Closed)
2	450	1	TWO-WAY SOLENOID PILOT, N.O.
3	451	1	TWO-WAY SOLENOID PILOT, N.C.
4	141-2	2	NEEDLE VALVE
5	123	1	INLINE STRAINER
6	150	1	LIMIT SWITCH ASSEMBLY (OPTIONAL)

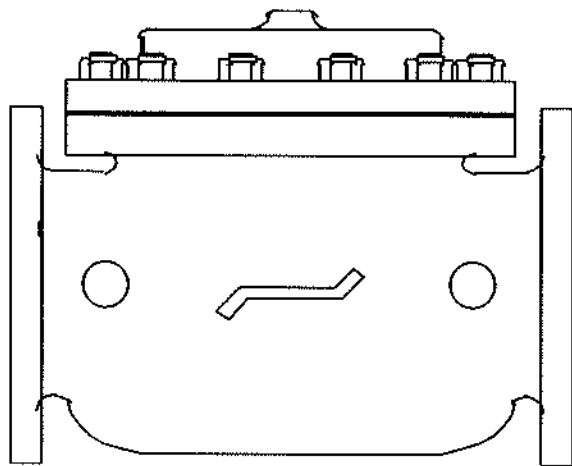

installation, operating, and maintenance instructions

series 65

basic control valve

GENERAL DESCRIPTION

The OCV Series 65 is a hydraulically-operated, diaphragm-actuated valve. It is available in either a globe (Model 65) or angle (Model 65A) configuration. The diaphragm is nylon-fabric bonded with synthetic rubber and forms a sealed chamber in the upper portion of the valve, separating operating pressure from line pressure. An elastomeric seat disc forms a tight seal with the valve seat when pressure is applied above the diaphragm.

FUNCTIONAL DESCRIPTION

Because the Series 65 is a hydraulically operated valve, it requires a minimum line pressure of approximately 5 psig in order to function. The valve functions on a simple principle of pressure differential. The line pressure at the inlet of the valve is bypassed through the pilot control piping to the diaphragm chamber of the valve. This pressure, together with the valve spring, works against the pressure under the valve seat. Because the effective area of the diaphragm is greater than that of the seat, the valve is held tightly closed. As the controlling pilot(s) allow the pressure to bleed off the diaphragm chamber, the two opposing pressures begin to balance and the valve will begin to open. The valve can be used to perform a simple on-off function, or with the proper pilot system, a modulating, or regulating function.

In cases where the line fluid is unusually dirty, or is otherwise unsuitable for operating the valve, an independent operating pressure source may be employed. The pressure available from such a source must be equal to, or greater than, line pressure.

INSTALLATION

In order to insure safe, accurate and efficient operation of the OCV control valve, the following list of checkpoints and procedures should be followed when installing the

valve.

1. Make a careful visual inspection of the valve to insure that there has been no damage to the external piping, fittings or controls. Check that all fittings are tight.
2. Thoroughly flush all interconnecting piping of chips, scale and foreign matter prior to mounting the valve.
3. Install the valve in the line according to the flow arrow on the inlet flange. The arrow should point downstream.
4. Allow sufficient room around the valve for ease of adjustment and maintenance service.

In addition, it is highly recommended that:

1. Isolation valves (eg., gate or butterfly) be installed on the inlet and discharge sides of the valve to facilitate isolating the valve for maintenance.
2. Pressure gauges be installed at the inlet and outlet sides of the valve to provide monitoring of the valve during initial start-up and during operation. The body side ports, if unused by the pilot system, provide a convenient connection for the gauges.
3. All valves larger than 6" be installed horizontally, i.e., with the bonnet pointed up, for ease of adjustment and maintenance servicing.

MAINTENANCE

The OCV control valve requires no lubrication and a minimum of maintenance. However, a periodic inspection should be established to determine how the fluid being handled is affecting the efficiency of the valve. In a water system, for example, the fluid velocity as well as the substances occurring in natural waters, such as dissolved minerals and suspended particles, vary in every installation. The effect of these actions or substances must be determined by inspection. It is recommended that an annual inspection, which includes ex-

amination of the valve interior, be conducted. Particular attention should be paid to the elastomeric parts, i.e., the diaphragm and seat disc. Any obviously worn parts should be replaced.

REPAIR PROCEDURES

In the event of malfunction of the OCV control valve, troubleshooting should be conducted according to the procedures outlined for the specific model of valve. Then, if those steps indicate a problem with the main valve, this section will outline the procedures necessary to correct the problem.

Problems with the main valve can be classed in three basic categories:

1. VALVE FAILS TO OPEN
 - a. Diaphragm damaged* - See Procedure A
 - b. Stem binding - See Procedure B
2. VALVE FAILS TO CLOSE
 - a. Diaphragm damaged* - See Procedure A
 - b. Stem binding - See Procedure B
 - c. Object lodged in valve - See Procedure B
3. VALVE OPENS AND CLOSES BUT LEAKS WHEN CLOSED
 - a. Seat disc damaged - See Procedure C
 - b. Seat ring damaged - See Procedure D

*A diaphragm failure can prevent the valve from either opening or closing, depending on the flow direction. Most water service valves flow "under the seat", in which case a diaphragm failure will keep the valve from closing. On the other hand, most fuel service valves flow "over the seat", in which case a diaphragm failure will keep the valve from opening. To determine which you have, examine the bridge mark cast into the side of the valve body, then compare it with the figures below.

PROCEDURE A : DIAPHRAGM REPLACEMENT

1. Isolate the valve from the system by closing upstream and downstream block valves.
2. Loosen one of the tubing connections on the bonnet. Allow any residual pressure to bleed off.
3. Remove all tubing connected at the bonnet.
4. Remove the bonnet nuts.
5. Remove the bonnet. If the bonnet sticks in place, it may be loosened by rapping sharply around its edge with a rubber-headed mallet. *NOTE: 8" and larger valves are equipped with eye bolts through which a chain can be fastened to aid in*

lifting the bonnet.

6. Remove the spring.
7. Remove the diaphragm plate capscrews and the diaphragm plate.
8. Remove the old diaphragm.
9. Making sure the dowel pin holes are in the proper location, place the new diaphragm over the studs and press down until it is flat against the body and spool.
10. Replace the diaphragm plate and the diaphragm plate capscrews.
11. Tighten all diaphragm plate capscrews snugly.
12. Replace the spring.
13. Replace the bonnet and reinstall the bonnet nuts.
14. Tighten the bonnet nuts snugly using a criss-cross tightening pattern.
15. Reinstall the control tubing.
16. Reopen the upstream and downstream block valves.
17. Before placing the valve back in service, perform the air bleed procedure described in the first section of this manual.

PROCEDURE B: CORRECTION OF BINDING STEM

1. Perform Steps 1 thru 6 of Procedure A, above.
2. Remove the spool assembly from the valve. *NOTE:*

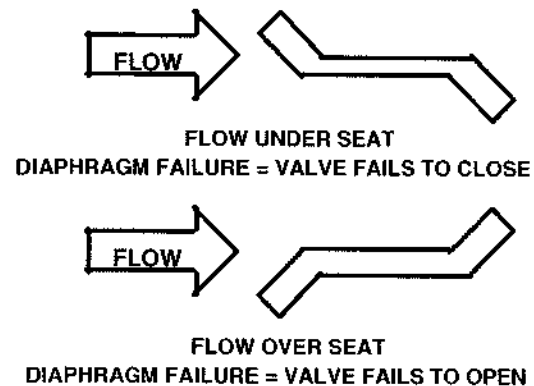

On smaller valves, this can be accomplished simply by grasping the stem and pulling upward. Valves 6" and larger have the top of the stem threaded to accept an eyebolt to aid in lifting the spool out of the body. 6" thru 12" valves are threaded 3/8-16. 14" and 16" valves are threaded 5/8-11.

3. Carefully examine both ends of the stem for deep scratches, scoring or buildup of mineral deposits.

Polish the stem if necessary using a fine grade of emery cloth.

4. Similarly, examine and polish the upper bushing (in the bonnet) and the lower guide (in the seat ring).
5. Reinstall the spool assembly.
6. Reassemble the valve, following Steps 12 thru 17 in Procedure A.

PROCEDURE C: SEAT DISC REPLACEMENT

1. Perform Steps 1 and 2 of Procedure B, above.
2. With the spool assembly removed from the body, remove the seat retainer screws.
3. Slide the seat retainer off the lower end of the stem.
4. Remove the seat disc from its groove in the spool.

NOTE: The seat disc may fit quite tightly in the groove. If necessary, it may be pried out using a thin-bladed screwdriver or similar tool.

5. Install the new seat disc in the groove.
6. Reinstall the seat retainer and tighten the seat retainer screws.
7. Reassemble the valve, following Steps 5 and 6 of Procedure B.

PROCEDURE D: SEAT RING REPLACEMENT

NOTE: It is rare for a seat ring to require replacement. Minor nicks and scratches in the seating surface can usually be smoothed out with emery cloth.

1. Perform Steps 1 and 2 of Procedure B, above.
2. If you are working on a 4" or smaller valve, follow Steps 3 thru 9, below.
3. If you are working on a 6" or larger valve, follow Steps 10 thru 16, below.

4. Seat rings in valves 4" and smaller are threaded into the valve body. To remove, you will need a special seat ring tool. You may fabricate one using standard pipe as shown in the sketch below, or one may be purchased from OCV.

5. Using the seat ring tool, unthread the seat ring from the body.
6. Remove the old o-ring from the counterbore in the body.
7. Install the new o-ring in the counterbore.
8. Using the seat ring tool, install the new seat ring.
9. Reassemble the valve, following Steps 5 & 6 of Procedure B.
10. Seat rings in valves 6" and larger are bolted into the body with socket head capscrews. In addition you will note that the seat ring is equipped with additional threaded holes that may be used for "jacking" the seat ring out of the body.
11. Remove the socket head capscrews.
12. Remove the old seat ring from the body by temporarily installing two or more of the capscrews in the "jacking" holes.
13. Install a new o-ring in the groove of the new seat ring. Lubricate the o-ring and outer seat ring wall with Vaseline® or similar lubricant.
14. Install the new seat ring in the body, making sure that the capscrew holes line up.
15. Replace and tighten all the capscrews.
16. Reassemble the valve, following Steps 5 and 6 of Procedure B.

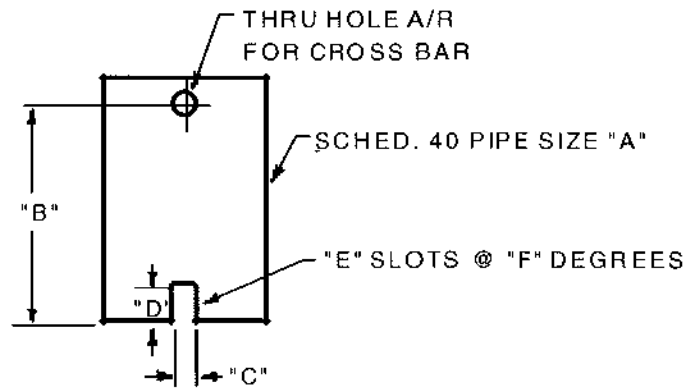

VALVE SIZE	"A" PIPE SIZE	"B" MIN. LENGTH	"C" SLOT WIDTH	"D" SLOT DEPTH	"E" NO. OF SLOTS	"F" SLOT SPACING
1-1/4"	3/4"	6"	3/8"	3/8"	2	180°
1-1/2"	3/4"	6"	3/8"	3/8"	2	180°
2"	1-1/2"	7"	3/8"	3/8"	2	180°
2-1/2"	2"	8"	1/2"	1/2"	3	120°
3"	2-1/2"	9"	5/8"	5/8"	2	180°
4"	3"	10"	5/8"	5/8"	2	180°

REVISED 3-17-97

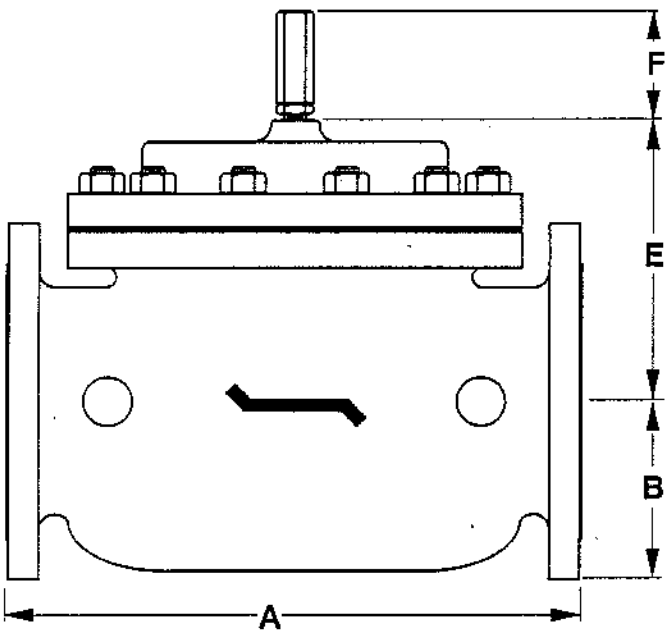
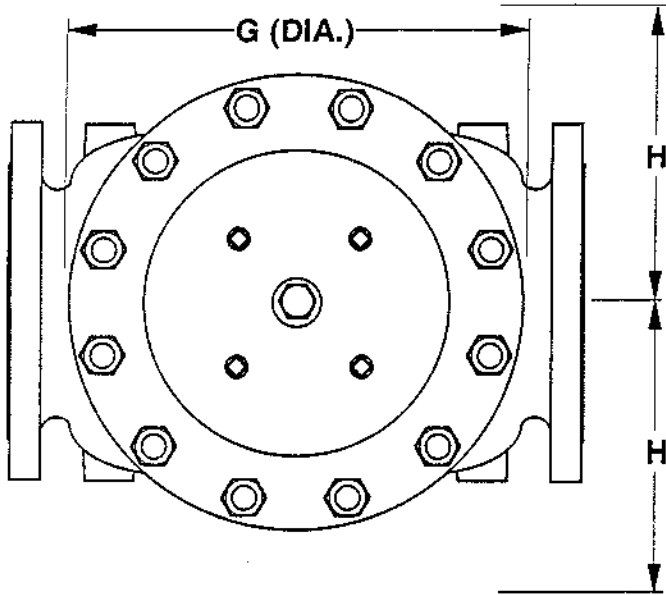

DIM	ANSI CLASS	VALVE SIZE												
		1 1/4	1 1/2	2	2 1/2	3	4	6	8	10	12	14	16	24
A	SE	8.75	8.75	9.88	10.50	13.00	-	-	-	-	-	-	-	-
	150	8.50	8.50	9.38	10.50	12.00	15.00	17.75	25.38	29.75	34.00	39.00	40.38	62.00
	300	8.75	8.75	9.88	11.12	12.75	15.62	18.62	26.38	31.12	35.50	40.50	42.00	63.75
B	SE	1.44	1.44	1.69	1.88	2.25	-	-	-	-	-	-	-	-
	150	2.31	2.50	3.00	3.50	3.75	4.50	5.50	6.75	8.00	9.50	10.62	11.75	16.00
	300	2.62	3.06	3.25	3.75	4.12	5.00	6.25	7.50	8.75	10.25	11.50	12.75	18.00
C	SE	4.38	4.38	4.75	6.00	6.50	-	-	-	-	-	-	-	-
	150	4.25	4.25	4.75	6.00	6.00	7.50	10.00	12.69	14.88	17.00	-	20.81	-
	300	4 3/8	4.38	5.00	6.38	6.38	7.81	10.50	13.19	15.56	17.75	-	21.62	-
D	SE	3.12	3.12	3.88	4.00	4.50	-	-	-	-	-	-	-	-
	150	3.00	3.00	3.88	4.00	4.00	5.50	6.00	8.00	11.38	11.00	-	15.69	-
	300	3.25	3.25	4.12	4.38	4.38	5.81	6.50	8.50	12.06	11.75	-	16.50	-
E	ALL	6.00	6.00	6.00	7.00	6.50	7.92	10.00	11.88	15.38	17.00	18.00	19.00	27.00
F	ALL	3.88	3.88	3.88	3.88	3.88	3.88	3.88	6.38	6.38	6.38	6.38	6.38	8.00
G	ALL	6.00	6.00	6.75	7.69	8.75	11.75	14.00	21.00	24.50	28.00	31.25	34.50	52.00
H	ALL	10.00	10.00	11.00	11.00	11.00	12.00	13.00	14.00	17.00	18.00	20.00	20.00	28.50

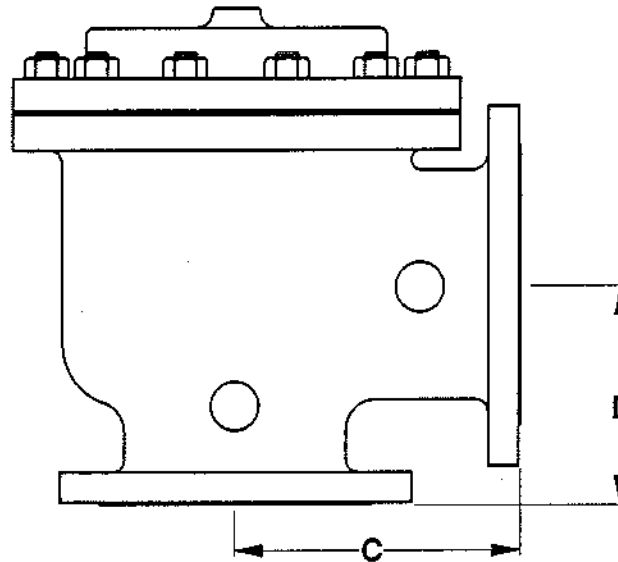

NOTE: 3" VALVE DIMENSIONS ARE FOR NEW MODEL 3100

4" VALVE DIMENSIONS ARE FOR NEW MODEL 4400

REV. A SDJ 6-6-02
REV. B SDJ 2-3-02

TOLERANCES		 OCV Control Valves TULSA, OKLAHOMA U.S.A.	
UNLESS NOTED FRACTIONAL $\pm 1/64$ DECIMAL $\pm .005$ MACH. FINISH 125/ $\sqrt{\quad}$ ANGULAR $\pm 1/2^\circ$			
GENERAL VALVE DIMENSIONS			
DRAWN BY SDJ	DATE 10-6-97	SIZE A	DRAWING NUMBER 65D
CHKD. BY	DATE		REV. B

Installation & Maintenance Instructions

2-WAY DIRECT-ACTING SOLENOID VALVES
 NORMALLY OPEN OR NORMALLY CLOSED OPERATION
 BRASS OR STAINLESS STEEL CONSTRUCTION - 1/8", 1/4", OR 3/8" NPT

SERIES

8262
8263

Form No. V6256R7

IMPORTANT: See separate solenoid installation and maintenance instructions for information on: Wiring, Solenoid Temperature, Causes of Improper Operation, and Coil or Solenoid Replacement.

DESCRIPTION

Series 8262 and 8263 valves are 2-way direct-acting general service solenoid valves. Valve bodies are of rugged brass or stainless steel. Series 8262 or 8263 valves may be provided with a general purpose or explosionproof solenoid enclosure.

Series 8262 and 8263 valves with suffix "P" in the catalog number are designed for dry inert gas and non-lubricated air service.

OPERATION

Normally Open: Valve is open when solenoid is de-energized; closed when energized.

Normally Closed: Valve is closed when solenoid is de-energized; open when energized.

IMPORTANT: No Minimum operating pressure required.

Manual Operator (Optional)

Manual operator allows manual operation when desired or during an electrical power outage. Two types of manual operators are available - push type (Suffix MO) and screw type (Suffix MS). To operate valve manually with push type operator, push stem at base of valve body as far upward as possible. Valve will now be in the same position as when the solenoid is energized. Removing pressure from stem will release manual operator to original position. To operate valve with a screw type manual operator, rotate manual operator stem at base of valve body clockwise until it hits a stop. Valve will now be in the same position as when the solenoid is energized. Rotate manual operator stem fully counterclockwise before operating valve electrically.

Flow Metering Devices

Valves with suffix "M" in catalog number are provided with a metering device for flow control. Turn stem to right to reduce flow; left to increase flow.

INSTALLATION

Check nameplate for correct catalog number, pressure, voltage, frequency, and service. Never apply incompatible fluids or exceed pressure rating of the valve. Installation and valve maintenance to be performed by qualified personnel.

Note: Inlet port will either be marked "1" or "IN". Outlet port will be marked "2".

Future Service Considerations.

Provision should be made for performing seat leakage, external leakage, and operational tests on the valve with a nonhazardous, noncombustible fluid after disassembly and reassembly.

Temperature Limitations

For maximum valve ambient and fluid temperatures, refer to charts below. Check catalog number, coil prefix, suffix, and watt rating on nameplate to determine the maximum temperatures.

Wattage	Catalog Number Coil Prefix	Coil Class	Max. Ambient Temp. °F	Max. Fluid Temp. °F
6, 10.5, 12.4	none, DA or S	A	77	180
6, 10.5 12.4	DF, FT or SF	F	125	180
6, 10.5, 12.4	HT	H	140	180
9, 10.7	none, DP or SP	F	77	180
9.7	none, FT or HT	A, F or H	77	120
11.2	none, FT or HT	A, F or H	77	150
16.7	none, DP or SP	F	77	200
17.1	none, KP SP or SD	F	125	180
17.1	HB, KB SS or SV	H	140	180

Catalog Nos. 8262B200 and 8262 C200 AC construction only and Catalog Nos. 8262B214 and 8262 D200 AC and DC construction are limited to 140°F fluid temperature.

Valves with Suffix V or W that are designed for AC service and normally closed operation are for use with No. 2 and 4 fuel oil service. These valves have the same maximum temperatures per the above table except Suffix V valves are limited to a maximum fluid temperature of 140°F.

Listed below are valves with Suffix V in the catalog number that are acceptable for higher temperatures.

Catalog Number Coil Prefix	Max. Ambi- ent Temp. °F	Max. Fluid Temp. °F
FT8262, HB8262 FT8263, HB8263 8262G, 8263G	125	250*
HT or HB 8262G HT or HB 8263G	140	250

*The only exception is the 8262G and 8263G series (Class F coil) at 50 Hertz rated 11.1 and 17.1 watts are limited to 210°F fluid temperature.

Positioning

This valve is designed to perform properly when mounted in any position. However, for optimum life and performance, the solenoid should be mounted vertically and upright to reduce the possibility of foreign matter accumulating in the solenoid base sub-assembly area. Valves with suffix "P" in the catalog number must be mounted with the solenoid vertical and upright.

Mounting

Refer to Figure 2 for mounting dimensions.

Piping

Connect piping or tubing to valve according to markings on valve body. Inlet port will either be marked "1" or "IN". Outlet port will be marked "2". Wipe the pipe threads clean of cutting oils. Apply pipe compound sparingly to male pipe threads only. If applied to valve threads, the compound may enter the valve and cause operational difficulty. Avoid pipe strain by properly supporting and aligning piping. When tightening the pipe, do not use valve or solenoid as a lever. Locate wrenches applied to valve body or piping as close as possible to connection point.

IMPORTANT: To protect the solenoid valve, install a strainer or filter suitable for the service involved, in the inlet side as close to the valve as possible. Clean periodically depending on service conditions. See ASCO Series 8600, 8601 and 8602 for strainers.

MAINTENANCE

▲ WARNING: To prevent the possibility of personal injury or property damage, turn off electrical power, depressurize valve, and vent fluid to a safe area before servicing the valve.

NOTE: It is not necessary to remove the valve from the pipeline for repairs.

Cleaning

All solenoid valves should be cleaned periodically. The time between cleanings will vary depending on the medium and service conditions. In general, if the voltage to the coil is correct, sluggish valve operation, excessive noise or leakage will indicate that cleaning is required. In the extreme case, faulty valve operation will occur and the valve may fail to open or close. Clean valve strainer or filter when cleaning the valve.

Preventive Maintenance

1. Keep the medium flowing through the valve as free from dirt and foreign material as possible.
2. While in service, the valve should be operated at least once a month to insure proper opening and closing.
3. Depending on the medium and service conditions, periodic inspection of internal valve parts for damage or excessive wear is recommended. Thoroughly clean all parts. If parts are worn or damaged, install a complete ASCO Rebuild Kit.

Causes of Improper Operation

1. **Incorrect Pressure:** Check valve pressure. Pressure to valve must be within range specified on nameplate.
2. **Excessive Leakage:** Disassemble valve (see Maintenance) and clean all parts. If parts are worn or damaged, install a complete ASCO Rebuild Kit.

Valve Disassembly

▲ WARNING: To prevent the possibility of personal injury or property damage, turn off electrical power, depressurize valve, and vent fluid to a safe area before servicing the valve.

1. Disassemble valve using exploded views for identification of parts.
2. Remove solenoid, see separate instructions.
3. Unscrew solenoid base sub-assembly or valve bonnet with special wrench adapter supplied in ASCO Rebuild Kit. For wrench adapter only, order No. K218-948. Remove core assembly, core spring, and solenoid base gasket from valve body. For normal maintenance on Series 8263 valves it is not necessary to remove valve seat. See Figure 1. for metering or manual operator constructions.
4. For normally open construction (Figure 3) remove end cap, or manual operator, (not shown) end cap gasket, disc holder spring, and disc holder assembly.
5. All parts are now accessible to clean or replace. If parts are worn or damaged, install a complete ASCO Rebuild Kit.

Valve Reassembly

1. Use exploded views for identification, orientation and placement of parts.
2. Lubricate all gaskets with DOW CORNING ● 111 Compound lubricant or an equivalent high-grade silicone grease.
3. For normally open construction (Figure 3), install disc holder assembly, disc holder spring, end cap gasket and end cap or manual operator. For valves with 1/8" NPT, torque end cap or manual operator to 90 ± 10 in-lbs (10.2 ± 1.1 Nm). For all other valves torque end cap or manual operator to 175 ± 25 in-lbs (19.8 ± 2.8 Nm).
4. For Series 8263 apply a small amount of LOCTITE ● PST ● pipe sealant to threads of valve seat (if removed). Follow manufacturer instructions for application of pipe sealant. Then install valve seat and torque to 75 ± 10 in-lbs (8.5 ± 1.1 Nm).
5. Replace solenoid base gasket, core assembly with core spring and solenoid base sub-assembly or plugnut/core tube sub-assembly and valve bonnet. Note: For core assemblies with internal type core springs, install wide end of core spring in core assembly first, closed end of core spring protrudes from top of core assembly.
6. For 1/8" NPT valve constructions, torque valve bonnet to 90 ± 10 in-lbs (10.2 ± 1.1 Nm). Torque solenoid base sub-assembly to 175 ± 25 in-lbs (19.8 ± 2.8 Nm).
7. Install solenoid, see separate solenoid instructions. Then make electrical hookup to solenoid.

▲ WARNING: To prevent the possibility of personal injury or property damage, check valve for proper operation before returning to service. Also perform internal seat and external leakage tests with a nonhazardous, noncombustible fluid.

8. Restore line pressure and electrical power supply to valve.
9. After maintenance is completed, operate the valve a few times to be sure of proper operation. A metallic "click" signifies the solenoid is operating.

ORDERING INFORMATION FOR ASCO REBUILD KITS

Parts marked with an asterisk (*) in the exploded view are supplied in Rebuild Kits.

* When Ordering Rebuild Kits for ASCO valves, order the Rebuild Kit number stamped on the valve nameplate. +

+ If the number of the kit is not visible, order by indicating the number of kits required, and the Catalog Number and Serial Number of the valve(s) for which they are intended.

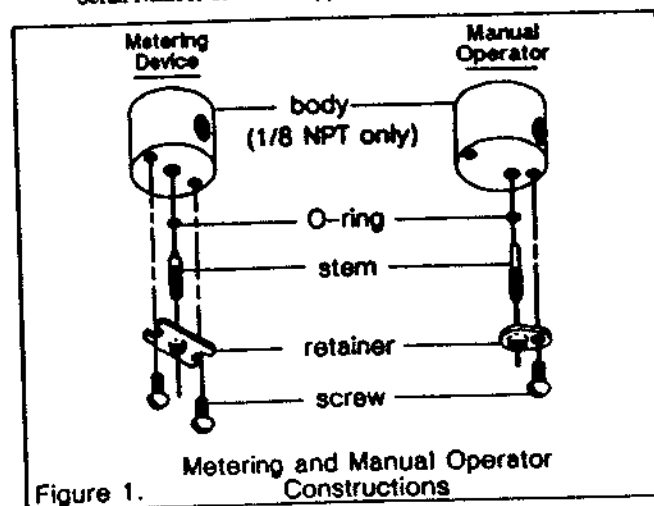
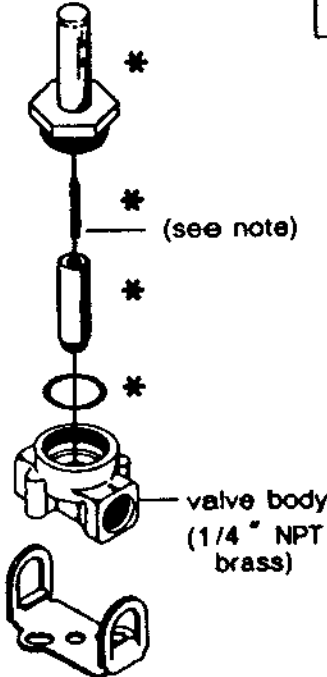
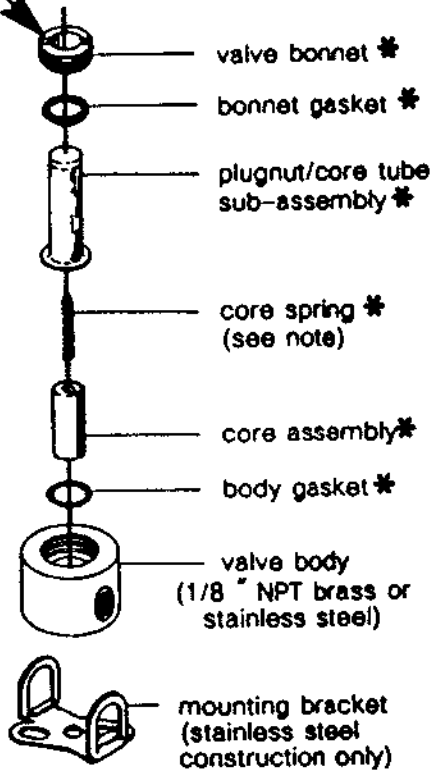

Figure 1.

Metering and Manual Operator
Constructions

*Bonnet wrench supplied in ASCO Rebuild Kits.
For bonnet wrench only order No. K218-948.



Torque Chart		
Part Name	Torque value Inch-Pounds	Torque value Newton-Meters
solenoid base sub-assembly	175 ± 25	19.8 ± 2.8
valve bonnet	90 ± 10	10.2 ± 1.1
valve seat	75 ± 10	8.5 ± 1.1

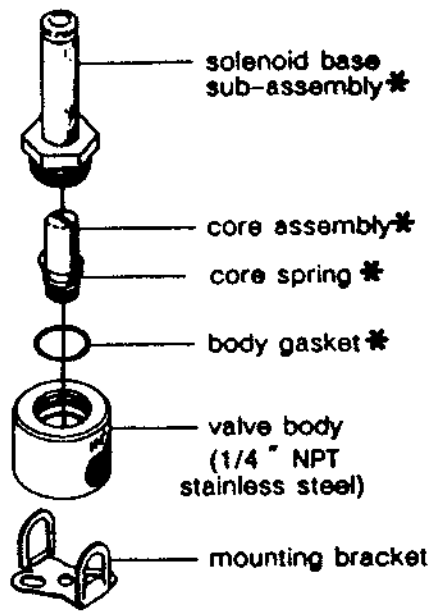

Series 8262

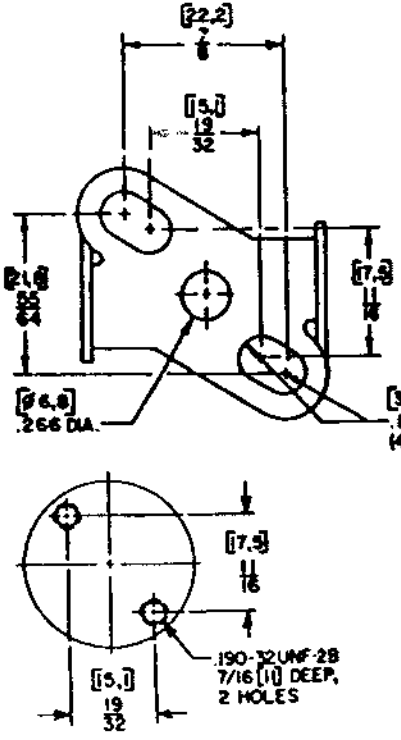

* Indicates Parts Supplied in ASCO Rebuild Kits.

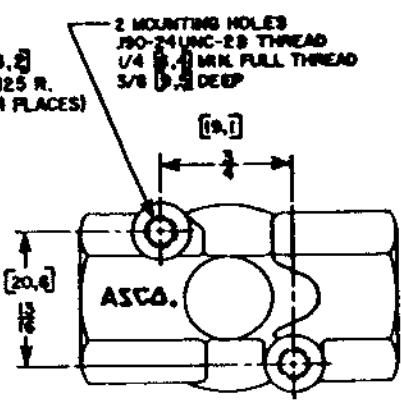
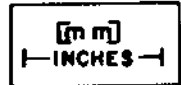

(1/8" NPT brass)

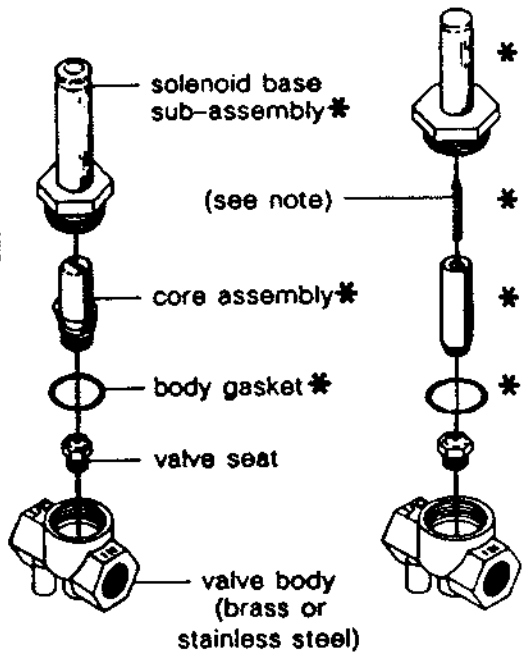

Series 8263

Note:
Wide end of core spring in core first,
closed end protrudes from top of core.

Figure 2. Series 8262 and 8263, Normally Closed Construction

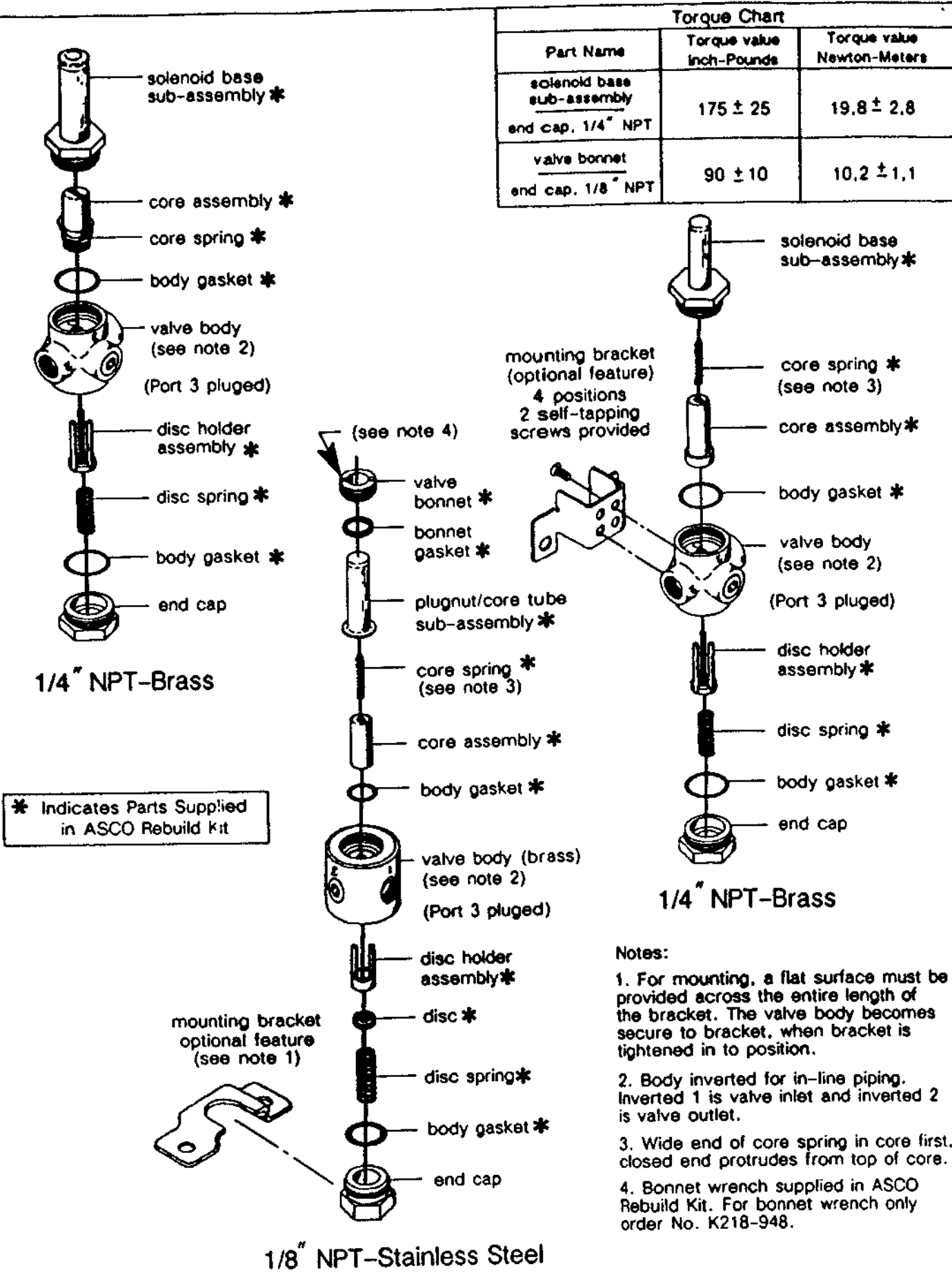

Figure 3. Series 8262, Normally Open Construction

DESCRIPTION

The Model 141-2 Needle Valve is an adjustable restriction device installed in the control circuit tubing. The setting of the needle valve meters the flow into and out of the main valve diaphragm chamber, thus controlling the response speed of the main valve. Depending on the application, the needle valve may be used as a closing speed control, opening speed control, or both simultaneously.



◀ Needle Valves shown
Sizes: 3/4" & 1/4"

MODEL 141-2 MATRIX

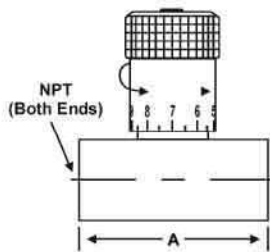

MATERIAL	PART NUMBER	INLET/OUTLET (NPT)	A	USED ON VALVE SIZE*
Brass	683100	1/4	2	1 1/4"-2"
Brass	683101	3/8	2 1/4	2 1/2"-6"
Brass	683102	1/2	2 5/8	8"-10"
Brass	683103	3/4	3 1/4	12"-16"
Stn. Steel	683700	1/4	2	1 1/4"-2"
Stn. Steel	683702	3/8	2 1/4	2 1/2"-6"
Stn. Steel	682704	1/2	2 5/8	8"-10"
Stn. Steel	683703	3/4	3 5/8	12"-16"

Note: Needle valve size may vary on valve application. Consult factory.

SCHEMATIC SYMBOL

The Model 141-2 Needle Valve is shown on OCV Valve Schematics as:

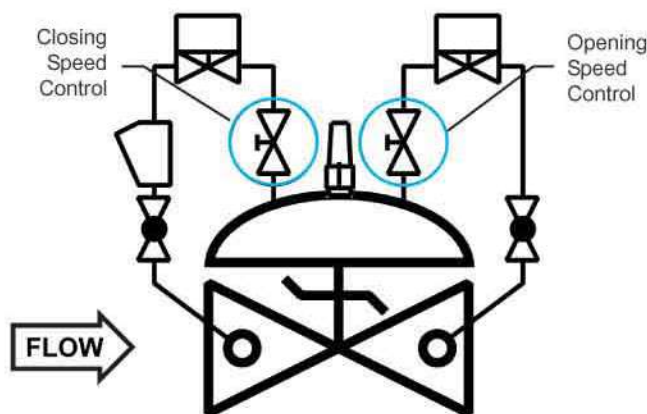
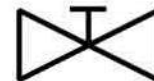

EXAMPLE: Shown here on a MODEL 115-3 DIGITAL VALVE as separate opening and closing speed controls.

DESCRIPTION

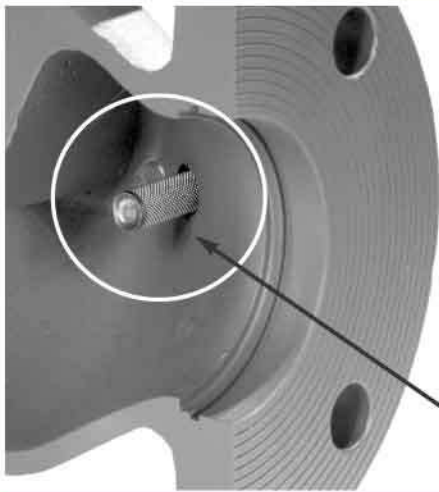

← Strainer Shown Installed

The 123 Inline Strainer installs in the inlet side port of the main valve, and protects the pilot system from solid contaminants in the line fluid. The screen prevents the entrance of particles into the pilot system piping while flow through the main valve washes the screen clean. Recommended use on petroleum valve applications where flushing or removal of the screen for cleaning is not practical or may be considered hazardous.

DIMENSIONS

PART NUMBER	A	B	C	D	E	USED ON VALVE SIZE
660704	3/8	1/4	11/16	2 3/16	1 1/2	1 1/4"-6"
660705	1/2	3/8	7/8	2 1/4	1 1/2	8"-10"
660706	3/4	1/2	1 1/8	2 3/8	1 1/2	12"-16"

MATERIALS

Inline strainers are all-stainless steel construction.

SCREEN SIZE

Standard screen is 40 mesh. Other mesh sizes are available.

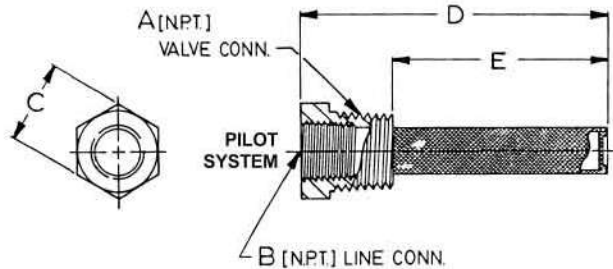

SCHEMATIC SYMBOL

The Model 123 Inline Strainer is shown on OCV Valve Schematics as:

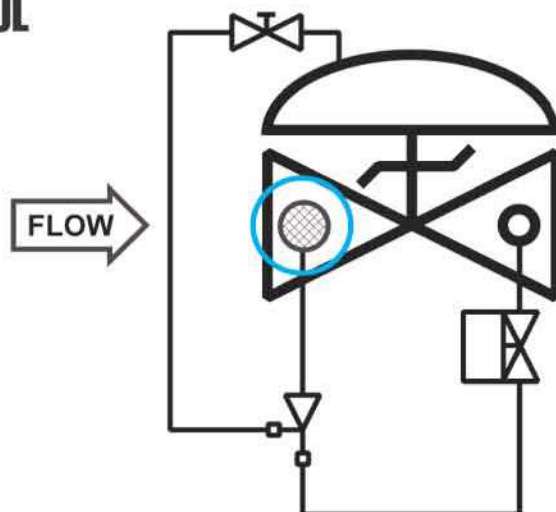

EXAMPLE: Shown here on a MODEL 115-2 Solenoid Valve.

DESCRIPTION

The Model 141-4 Ball Valve is a 1/4-turn shutoff device used for isolating the pilot system from the main valve. They are extremely useful for performing routine maintenance and troubleshooting.

Ball valves are standard on water service valves; optional on fuel service valves.

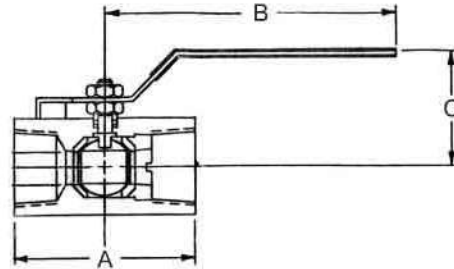

MODEL 141-4 MATRIX

MATERIAL	PART NUMBER	INLET/OUTLET (NPT)	A	B	C	USED ON VALVE SIZE*
Bronze	680100	3/8	1 3/4	3 1/2	1 7/8	1 1/4"-6"
Bronze	680101	1/2	2	3 1/2	2 1/4	8"-10"
Bronze	680102	3/4	3	4 3/4	2 1/4	12"-16"
Stn. Steel	680700	3/8	2	3 3/4	2 1/8	1 1/4"-6"
Stn. Steel	680701	1/2	2 1/4	3 3/4	2 1/2	8"-10"
Stn. Steel	680702	3/4	3	4 3/4	2 1/4	12"-16"

SCHEMATIC SYMBOL

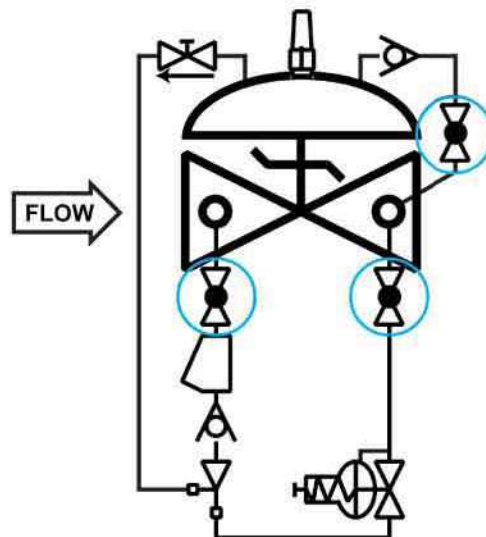

The Model 141-4 Ball Valve is shown on OCV Valve Schematics as:

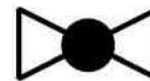

EXAMPLE: Shown here on a MODEL 127-4 Pressure Reducing / Check Valve.

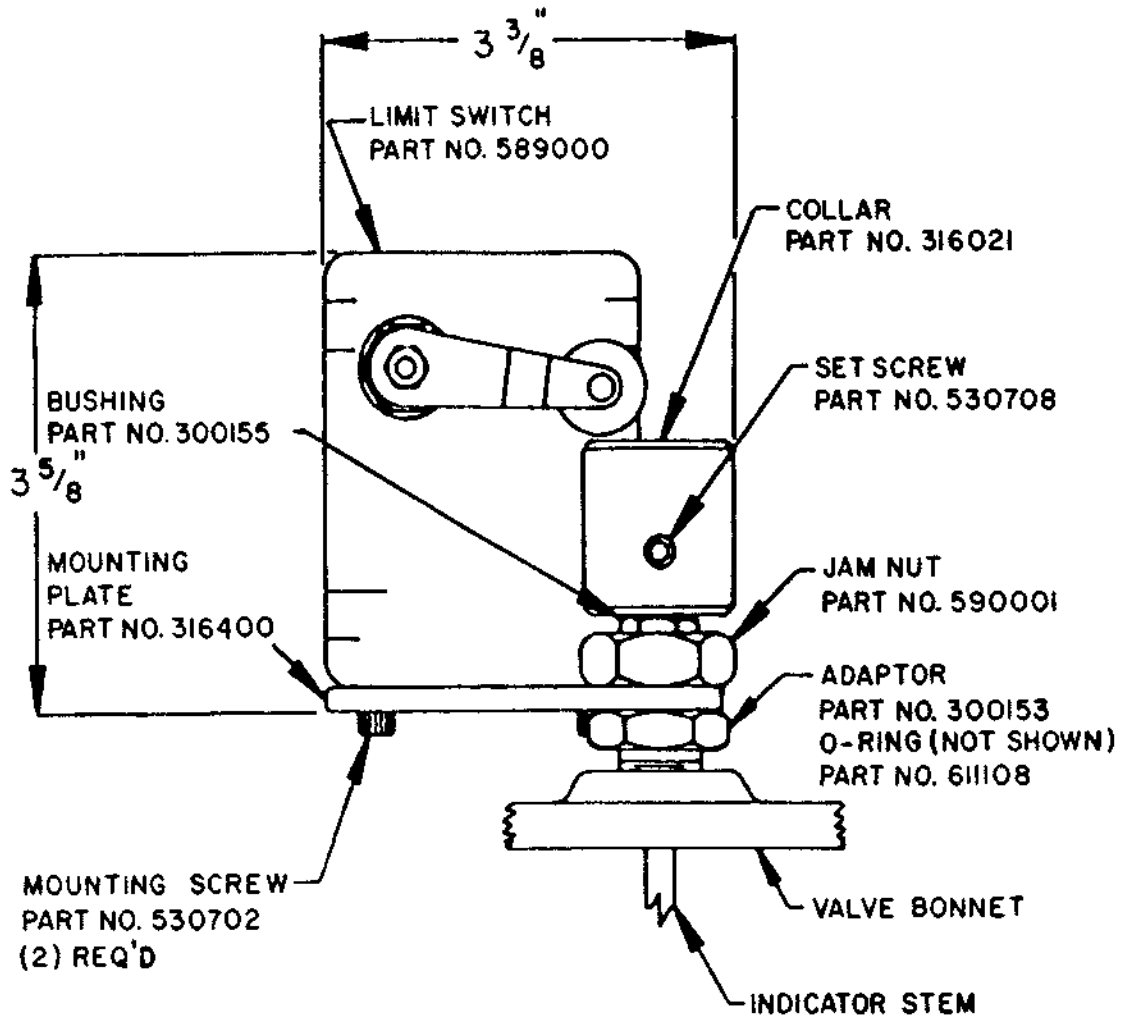

**MODEL 150
LIMIT SWITCH ASSEMBLY**