



▲ Model 125-7

The Model 125-7, primarily designed for use with centrifugal booster pumps, can also be used on well pumps with relatively shallow lifts where the pump design permits starting against a closed valve.

Because of its lift check feature, the 125-7 is ideally suited to those pumping applications where little or no back flow can be tolerated.

SERIES FEATURES

- ▶ Eliminates surges associated with starting and stopping the pump
- ▶ Pump starts against a closed valve that then gradually opens at a controlled rate
- ▶ Valve gradually closes at a controlled rate while pump continues to run
- ▶ Pump stops when valve is fully closed
- ▶ Integral lift check feature closes valve immediately on power failure
- ▶ Separate adjustable opening and closing speeds
- ▶ Can be maintained without removal from the line
- ▶ Factory tested

OPERATION

The 125-7 is controlled by an electrical 3-way solenoid which is energized at pump start. This causes the valve to open at an adjustable controlled rate, smoothly transitioning flow into the system. At shut-down the solenoid is de-energized, causing the valve to close at an adjustable controlled rate while the pump (held on by the valve limit switch) continues to run. When the valve is fully closed, the pump is finally shut off.

In the event of power failure while the pump is running, the internal lift check feature will close immediately, thereby minimizing any back flow.

COMPONENTS

The Model 125-7 consists of the following components, arranged as shown on the schematic diagram:

- 1.) Model 65SC Basic Valve Assembly with Lift Check
- 2.) Model 452 Three-Way Solenoid Pilot
- 3.) Model 3600 Three-Way Auxiliary Pilot
- 4.) Model 141-3 Flow Control Valve
- 5.) Model 141-1 Check Valve
- 6.) Model 159 Y-Strainer
- 7.) Model 141-4 Isolation Ball Valves
- 8.) Model 31 Limit Switch Assembly

SCHEMATIC

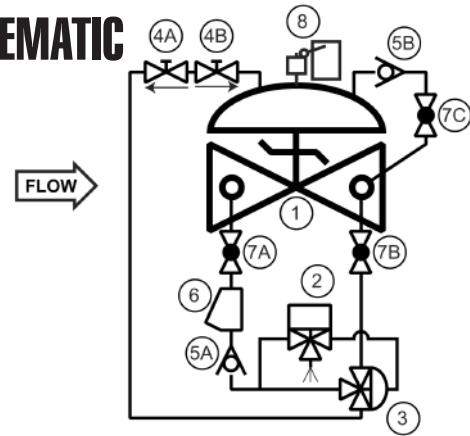

RECOMMENDED INSTALLATION

OCV recommends that all Model 125-7 valves be installed horizontally, bonnet "up."

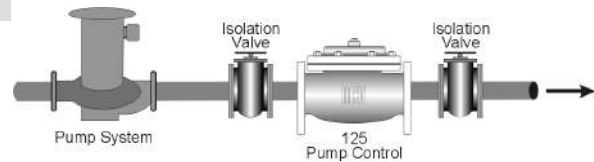

TYPICAL WIRE DIAGRAM

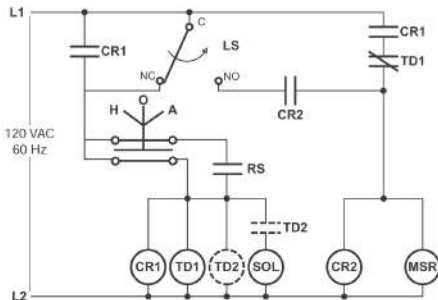

MAX. PRESSURE

The pressures listed below are maximum pressures at 100°F.

END CONNECTIONS	DUCTILE IRON	STEEL/STN STL	LOW-LEAD BRONZE
Threaded	400 psi	400 psi	400 psi
Grooved	300 psi	300 psi	300 psi
150# Flanged	250 psi	285 psi	225 psi
300# Flanged	400 psi	400 psi	400 psi

SIZING

Booster pump control valves are typically the same size as the pump discharge; however, flow rate should not exceed a velocity of 20 ft/sec, as shown below. For a more definitive sizing procedure, refer to our ValveMaster software program or the Performance Charts in the OCV Catalog Engineering Section.

SIZE	1 1/4"-1 1/2"	2"	2 1/2"	3"	4"	6"	8"	10"	12"	14"	16"	24"
FLOW @ 20FT/SEC GPM	85 - 120	210	300	460	800	1800	3100	4900	7000	8450	11000	25000

TOLL FREE 1.888.628.8258 • phone: (918)627.1942 • fax: (918)622.8916 • 7400 East 42nd Place, Tulsa, Ok 74145
 email: sales@controlvalves.com • website: www.controlvalves.com

Model 125-7



SIZES GLOBE/ANGLE
 Screwed Ends - 1 1/4" - 3"
 Grooved Ends - 1 1/2" - 6" (globe);
 1-1/2"-4" (angle)
 Flanged Ends - 1 1/4" - 24" (globe);
 1 1/4" - 16" (angle)

FLUID OPERATING TEMPERATURE RANGE
 (Valve Elastomers)
 EPDM 32° F - 230°F*

MATERIALS - Consult factory for others.
Body/Bonnet: Ductile Iron (epoxy coated),
 Carbon Steel (epoxy coated), Stainless
 Steel, low-lead Bronze, Others available
 (consult factory)

Seat Ring: low-lead Bronze, Stainless Steel

Stem: Stainless Steel, Monel

Spring: Stainless Steel

Diaphragm: EPDM*

Seat Disc: EPDM*

Pilot: low-lead Bronze, Stainless Steel

Other pilot system components:

low-lead Bronze/Brass, All Stainless Steel

Tubing & Fittings: Copper/Brass, Stainless
 Steel

Solenoid: 3-way type**

Enclosure: *Weatherproof NEMA 4X;*

Explosion Proof NEMA 4X, 6P, 7, 9

Body: Brass, Stainless Steel

Voltagess: 24, 120, 240, 480 VAC; 12, 24

VDC

Note: working pressures of solenoids vary
 greatly, consult factory on application of
 OCV Model 125-7 valves.

Limit Switch:

Enclosure: *Weatherproof NEMA 4;*

Explosion Proof NEMA 7.9

Contacts: SPDT (std) / DPDT (opt)

*Others available upon request.

**Consult factory for NSF 372 listed
 Model 125-7 valves.

SPECIFICATIONS (Typical Water Application)

The pump control valve shall function to eliminate the surges from starting and stopping the pump. The valve shall be closed when the pump is started. It shall open slowly, gradually introducing flow into the line. When the pump is signaled to stop, the pump control valve shall close slowly while the pump continues to run. As the valve approaches the full closed position, the valve stem shall trip a limit switch mounted on the valve. The limit switch shall then shut down the pump. Opening and closing speeds shall be independently adjustable. In the event of a power failure while the pump is running, the valve shall close quickly by means of its lift check feature to prevent back flow.

DESIGN

The valve shall be a single-seated, line pressure operated, diaphragm actuated, pilot controlled globe valve, and shall contain an internal lift check feature. The valve shall seal by means of a corrosion-resistant seat and a resilient, rectangular seat disc. These, and other parts, shall be replaceable without removing the valve from the line. The stem of the main valve shall be guided top and bottom by integral bushings. Alignment of the body, bonnet and diaphragm assembly shall be by precision dowel pins. The diaphragm shall not be used as a seating surface, nor shall the pistons be used as an operating means. The pilot system shall be furnished complete and installed on the main valve. It shall include separate opening and closing speed controls, a Y-strainer and isolation ball valves. The valve shall be operationally and hydrostatically tested prior to shipment.

MATERIALS OF CONSTRUCTION

The main valve body and bonnet shall be ductile iron per ASTM A536, Grade 65-45-12. All ferrous surfaces shall be coated with 4 mils of epoxy. The main valve seat ring shall be low-lead Bronze. Elastomers (diaphragms, resilient seats and O-rings) shall be EPDM. Control pilots shall be low-lead Bronze. The speed controls and isolation ball valves shall be brass, and control line tubing shall be copper. The solenoid coil shall be suitable for operation on 110-120 volts AC, 50-60 Hz. The limit switch shall be equipped with SPDT contacts rated at 15 amps at 125-480 VAC. Limit switch and solenoid enclosures shall be weatherproof per NEMA 4.

OPERATING CONDITIONS

The pump control valve shall be suitable for a flow of <X> gpm and a maximum pump shutdown pressure of <X> psig.

ACCEPTABLE PRODUCTS

The pump control valve shall be a <size> Model 125-7, <globe pattern, angle pattern>, with <150# flanged, 300# flanged, threaded, grooved> end connections, as manufactured by OCV Control Valves, Tulsa, Oklahoma, USA.

U.S. DIMENSIONS - INCHES

DIM	END CONN.	1 1/4-1 1/2	2	2 1/2	3	4	6	8	10	12	14	16	24
A	SCREWED	8 3/4	9 7/8	10 1/2	13	--	--	--	--	--	--	--	--
	GROOVED	8 3/4	9 7/8	10 1/2	13	15 1/4	20	--	--	--	--	--	--
	150# FLGD	8 1/2	9 3/8	10 1/2	12	15	17 3/4	25 3/8	29 3/4	34	39	40 3/8	62
C	SCREWED	4 3/8	4 3/4	6	6 1/2	--	--	--	--	--	--	--	--
	GROOVED	4 3/8*	4 3/4	6	6 1/2	7 5/8	--	--	--	--	--	--	--
	150# FLGD	4 1/4	4 3/4	6	6	7 1/2	10	12 11/16	14 7/8	17	--	20 13/16	--
D	SCREWED	3 1/8	3 7/8	4	4 1/2	--	--	--	--	--	--	--	--
	GROOVED	3 1/8*	3 7/8	4	4 1/2	5 5/8	--	--	--	--	--	--	--
	150# FLGD	3	3 7/8	4	4	5 1/2	6	8	11 3/8	11	--	15 11/16	--
E	ALL	6	6	7	6 1/2	8	10	11 7/8	15 3/8	17	18	19	27
	ALL	3 7/8	3 7/8	3 7/8	3 7/8	3 7/8	3 7/8	6 3/8	6 3/8	6 3/8	6 3/8	6 3/8	8
	ALL	10	11	11	11	12	13	14	17	18	20	20	28 1/2

*GROOVED END NOT AVAILABLE IN 1 1/4"

For maximum efficiency, the OCV control valve should be mounted in a piping system so that the valve bonnet (cover) is in the top position. Other positions are acceptable but may not allow the valve to function to its fullest and safest potential. In particular, please consult the factory before installing 8" and larger valves, or any valves with a limit switch, in positions other than described. Space should be taken into consideration when mounting valves and their pilot systems.

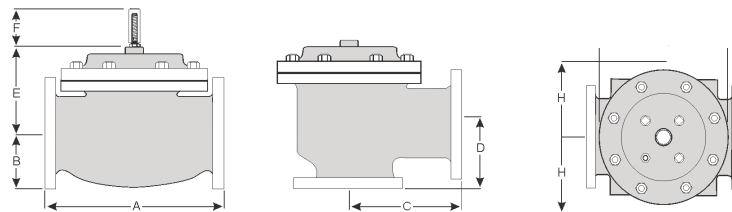

A routine inspection & maintenance program should be established and conducted yearly by a qualified technician. Consult our factory @ **1-888-628-8258** for parts and service.

How to order your Model 125-7 valve

When Ordering please provide:

Fluid to be controlled -Model Number -Size

Globe or Angle -End Connection -Body Material

Trim Material -Solenoid Voltage -Solenoid Enclosure

Weatherproof or Explosion Proof -Special

Requirements / Installation Requirements

Represented by:

TOLL FREE 1.888.628.8258 • phone: (918)627.1942 • fax: (918)622.8916 • 7400 East 42nd Place, Tulsa, Oklahoma 74145
 email: sales@controlvalves.com • website: www.controlvalves.com