

# booster pump control valve

## installation, operating, and maintenance instructions

# model 125

### GENERAL DESCRIPTION

The OCV Model 125 is designed to effectively eliminate the surges associated with the starting and stopping of booster-type pumps, as well as act as the pump discharge check valve. Electrically interfaced with the pump, the 125 performs these functions by:

1. Slowly opening after pump start.
2. Slowly closing prior to pump shutdown.
3. Closing rapidly as a check valve in the event of power failure.

Intended primarily for horizontal, split-case centrifugals, the 125 can also be used on vertical turbine pumps with relatively shallow suction lifts.

The 125 consists of the following components, arranged as shown on the schematic diagram:

1. **Model 65 Basic Valve**, a hydraulically-operated, diaphragm-actuated, globe or angle valve with an elastomer-on-metal seal.
2. **Model 452 Three-Way Solenoid Pilot**, which "converts" the electrical control signals into hydraulic signals to open and close the valve. Applying power to the solenoid causes the valve to open.
3. **Model A224 or 3600 Accelerator Pilot**, a hydraulically-operated, diaphragm-actuated control pilot. This pilot physically amplifies the small-scale hydraulic signals from the three-way solenoid pilot into the large-scale signals necessary for operating the main valve.
4. Two **Model 141-3 Flow Control Valves**, needle-type valves which provide adjustable, restricted flow in one direction and free flow in the opposite

direction. Connected in series but in opposite directions, one acts as the opening speed control, the other as the closing speed control.

5. Two **Model 141-1 Check Valves**, which enable the 125 to close as a check valve under power failure conditions.
6. **Model 159 Y-Strainer** which protects the pilot system from solid contaminants in the line fluid.
7. Three **Model 141-4 Ball Valves**, useful for isolating the pilot system for maintenance or troubleshooting.
8. **Model 150 Limit Switch Assembly**, which electrically interfaces the valve and the pump.

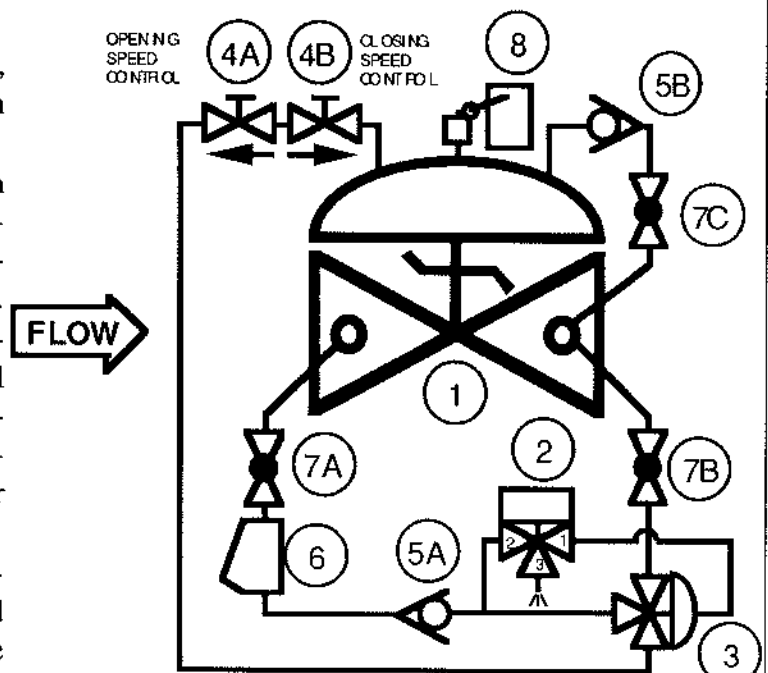

## **THEORY OF OPERATION** (refer to schematic diagram):

Before we begin the explanation of how the 125 operates, take a few moments to familiarize yourself with the schematic diagram. In particular, note the arrows on the flow control valves 4A and 4B. These arrows match the arrows actually stamped into the bodies of these controls and point in the direction of **adjustable, restricted** flow. Thus 4A is the Opening Speed Control and 4B is the Closing Speed Control.

Also note that a certain amount of electrical components and circuitry are required to interface the valve and pump. Drawing SK1134 is included in this manual as an example of such a circuit. Its operation will be described in detail later.

In the meantime, let's look at how the valve itself operates:

### **A. NORMAL STARTING CYCLE**

Starting the pump simultaneously applies power to the solenoid pilot (2). The pilot shifts to connect Port 2 to Port 1 and block Port 3. This applies full valve inlet pressure to the diaphragm chamber of the accelerator pilot (3). This pilot shifts to connect Port B to Port C and block Port A. Thus, the pressure in the diaphragm chamber of the main valve (1) is routed to the downstream side of the valve. This causes the valve to open, but at the rate set on Opening Speed Control 4A. What we have succeeded in doing is to start the pump against a **closed** valve, then open the valve **smoothly and slowly** so as to eliminate any startup surge on the line. As the valve started open, it actuated the limit switch (8), which, as we shall see later, holds the pump "on."

### **B. NORMAL SHUTDOWN CYCLE**

Pump shutdown is initiated by first removing power from the solenoid pilot (2). The pilot shifts to connect Port 1 to Port 3 and block Port 2. This vents the diaphragm chamber of the accelerator pilot (3), causing it to shift, connecting Port A to Port B and blocking Port C. Full valve inlet pressure can now build up on the diaphragm chamber of the main valve. Thus, the valve goes full closed, but at the rate set on the Closing Speed Control (4B). As the valve reaches the full closed position, the limit switch (8) is reset, which finally stops the pump. We have virtually eliminated any shutdown surge by:

1. Closing the valve slowly, and

2. Precluding any possibility of reverse flow by keeping the pump running until the valve is closed.

### **C. EMERGENCY SHUTDOWN CYCLE**

Assume the pump is running and the valve is open when we suddenly lose electrical power. Obviously, we can't go through a normal shutdown cycle, as the pump will stop immediately upon loss of power. However, the 125 is equipped with the means to close and prevent excessive backflow. A few moments after the pump stops, the pressure reverses itself and downstream (system side) pressure will become the highest. Check valve 5B opens and applies downstream pressure to the main valve diaphragm chamber, readily closing the valve. In this way, we have ensured a quick, positive closure, holding backflow to a minimum and any shutdown surge to within tolerable limits. Meanwhile check valve (5A) closes, preventing any backflow through the pilot system.

To complete the picture, let's go through the same three sequences again, this time focusing on the wiring diagram, SK1134. For the time being, ignore TD2: it is an optional item as will be explained later.

### **A. NORMAL STARTING CYCLE**

The pump is started either by placing the HOA switch in "hand," or by placing it in "AUTO" and also closing the Remote Start Switch (RS). Either way, power is applied through the NC contact of the Limit Switch (LS) to TD1, CR1 and the Solenoid Pilot (SOL). Both sets of CR1 contacts immediately close. The first set acts as a latch to keep power on the starting circuit. The second set applies power through the still-closed contacts of TD1 to CR2 and the Motor Starter Relay (MSR). The latter starts the pump.

With SOL energized, the valve starts open. After a small degree of opening, the LS switches from "NC" to "NO." This supplies a second "leg" of power to CR2 and MSR, so that when TD1 times out and its contacts open, the pump continues running.

### **B. NORMAL SHUTDOWN CYCLE**

Shutdown is initiated by turning the HOA switch to "OFF" (or, if in "AUTO," by opening RS). This deenergizes TD1, CR1 and SOL. The latter causes the valve to start closed. However, the pump remains running because power is still available to MSR through the N.O. contacts of LS and the closed contacts of CR2.

Finally, as the valve reaches the full closed position, LS switches back to N.C., power is removed from CR2 and MSR, and the pump stops. The valve and pump are ready for the next cycle.

### C. EMERGENCY SHUTDOWN CYCLE

There's not much to explain here, as there isn't any electricity flowing through the circuit! However, it is worthwhile to note that even if the power failure is momentary, the pump will not restart until after the valve reaches the closed position. This way we are assured of always starting the pump against a closed valve.

As mentioned previously, time delay relay TD2 is an optional item which can have utility in certain applications. With its normally-open contact wired in series with the coil of the solenoid pilot, TD2 will delay the opening of the valve for a predetermined length of time after the pump starts. This can be particularly useful when the 125 is installed on the discharge of a vertical turbine or submersible pump. In these cases, it is common to employ an air release valve to exhaust the air in the pump column when the pump starts. TD2 can then be used to keep the valve closed until all the air is exhausted.

## INSTALLATION

Refer to the Model 65 Basic Valve section of this manual contains the details of valve installation in general.

Following the mechanical installation of the valve, wiring must be completed to properly interface the valve and pump. This can be accomplished one of three ways:

1. With an OCV Pump Commander, a factory-wired control panel that includes all the components necessary for proper interfacing. If a Pump Commander was purchased with the valve, its installation and operation is covered later in this manual.
2. As shown in diagram SK1134, which was explained above.
3. With any other wiring diagram designed so that the pump starts and stops against a closed valve. If in doubt, consult OCV Engineering.

## STARTUP AND ADJUSTMENTS

The following procedures should be followed in the

order presented in order to effect an initial startup of the 125.

1. Loosen the adjusting screw jam nuts on speed controls 4A and 4B. Turn the adjusting screws on **both** controls **fully clockwise**, then **counterclockwise one full turn**.
2. Check the limit switch setting. With the valve closed, the top of the collar on the indicator stem should be approximately 1/32" **below** the roller on the limit switch arm. If necessary, loosen the set screw in the side of the collar, reposition the collar and re-tighten the set screw.
3. Close ball valve (7B).
4. Set TD1 to its maximum delay setting.
5. Start the pump. The valve should remain closed, or else open only a small amount.
6. Carefully loosen a pipe plug in the bonnet of the main valve until water begins to discharge around the threads. When only clear water (no air) is discharging, re-tighten the plug.
7. Open ball valve (7B). The main valve should now open.
8. Allow the pump to run long enough for TD1 to time out. The pump should continue to run. If the downstream lines had not been previously filled, allow them to do so at this time.
9. Initiate a pump shutdown. The valve should close at a relatively slow rate while the pump continues running. When the valve completes its closure, the pump should stop.
10. If necessary, run the pump through several startup/shutdown cycles to properly adjust the speed controls. The best settings are those that result in the **smoothest** operation with a minimum of surges. Adjustment for both controls is **clockwise to decrease** speed; **counterclockwise to increase** speed. **CAUTION: Do not adjust either of these controls to the full closed position. To do so can prevent the valve from opening and/or closing.**
11. Reset TD1 to the desired setting.

## MAINTENANCE

Required maintenance of the 125 is minimal. However, the following checks, periodically performed, will do much to keep the valve operating properly and efficiently.

1. Check for chipped or peeling paint. Touch up as required.
2. Check for leaks at fittings and around flanges and connections. Tighten as required.
3. Check that all electrical wiring is secure.
4. If the valve is equipped with a Y-strainer, check the screen for buildup of solid material. Clean as required. This point is most important, as a clogged strainer can keep the valve from closing. On new installations, it is recommended that the strainer be checked every day or two until experience dictates a greater or lesser interval. Strainer maintenance is covered in detail on a special page later in this manual.

### **TROUBLESHOOTING**

In the event of malfunction of the 125, the following guide should enable the technician to isolate the specific cause of the problem and take the appropriate corrective action.

#### **MAIN VALVE FAILS TO OPEN**

1. Determine if the Solenoid Pilot (2) is exhausting water continuously. If so, it is stuck in an intermediate position or its seats are bad. Disassemble and determine cause. See the 8320 Solenoid Valve section of this manual.
2. Ball valve (7B) closed. Open as required.
3. Opening Speed Control (4A) adjusted full closed. Open as required. See Adjustment Instructions.
4. Carefully loosen the connection between the Solenoid pilot (2) and the Accelerator pilot (3).
  - a. If the line is not pressurized at all, proceed to Step 5.
  - b. If the line is pressurized from the solenoid pilot only, proceed to Step 8.
  - c. If pressure is coming from the bonnet of the accelerator pilot, proceed to Step 7.
5. Solenoid pilot (2) is not being energized. Check control circuitry.
6. Solenoid pilot is stuck in closed position or coil is burned out. See the 8320 Solenoid Valve section of this manual.
7. Diaphragm of Accelerator pilot ruptured. Disassemble pilot and replace diaphragm. See the A224 or 3600 Pilot section of this manual.
8. Stem binding or seat deteriorated in Accelerator

pilot (3). Disassemble pilot and determine cause. See the A224 or 3600 Pilot section of this manual.

9. Main valve stem binding. Disassemble valve and determine cause. See Model 65 Basic Valve section of this manual.

#### **MAIN VALVE OPENS, BUT PUMP SHUTS DOWN WHEN TDI TIMES OUT**

1. Defective component or wiring in control circuit. Check control circuitry.
2. Limit switch misadjusted. See Adjustment Instructions.
3. Limit switch faulty. Replace.

#### **MAIN VALVE FAILS TO CLOSE (NORMAL SHUTDOWN - PUMP RUNNING)**

1. Determine if the Solenoid pilot (2) is exhausting water continuously. If so, it is stuck in an intermediate position or its seats are bad. Disassemble and determine cause. See the 8320 Solenoid Pilot section of this manual.
2. Ball Valve (7A) closed. Open as required.
3. Strainer (6) clogged. Clean as required.
4. Closing Speed Control (4B) adjusted full closed. Open as required. See Adjustment Instructions.
5. Check valve (5A) clogged or stuck closed. Repair or replace as necessary.
6. Close ball valve (7C).
  - a. If valve then closes, check valve (5B) is stuck open or leaking badly. Repair or replace as required.
  - b. If valve still does not close, leave ball valve (7C) closed and proceed to Step 7.
7. Also close ball valves (7A) and (7B) and carefully loosen a pipe plug in the main valve bonnet.
  - a. A continuous discharge of water indicates that the main valve diaphragm is ruptured. Replace diaphragm. See the Model 65 Basic Valve section of this manual.
  - b. If you get a momentary or no discharge of water from the loosened plug, the main valve diaphragm is O.K. Reopen the ball valves and proceed to Step 8.
8. Carefully loosen the connection between the Solenoid pilot (2) and the bonnet of the Accelerator pilot (3).

- a. If the line is pressurized, proceed to Step 9.
- b. If the line is not pressurized, proceed to Step 11.
- 9. Solenoid pilot (2) is not being deenergized. Check control circuitry.
- 10. Solenoid pilot (2) stuck open. Disassemble and determine cause. See the 8320 Solenoid Valve section of this manual.
- 11. Stem of Accelerator pilot (3) binding or seat deteriorated. Disassemble and determine cause. See the A224 or 3600 Pilot section of this manual.
- 12. Stem of main valve binding or object caught in valve. Disassemble valve and determine cause. See the Model 65 Basic Valve section of this manual.

2. Limit Switch (9) misadjusted. See Adjustment Instructions.

3. Limit Switch (9) faulty. Replace

**MAIN VALVE CLOSES BUT ALLOWS REVERSE FLOW**

- 1. Ball Valve (7C) closed. Open as required.
- 2. Check Valve (5B) clogged or stuck closed. Repair or replace as necessary.
- 3. Check Valve (5A) leaking or stuck open. Repair or replace as necessary.
- 4. Main Valve seat damaged or object caught in valve. Disassemble valve and determine cause. See the Model 65 Basic Valve section of this manual.

**MAIN VALVE CLOSES BUT PUMP CONTINUES TO RUN**

- 1. Defective component or wiring in control circuit. Check control circuitry.

**SK1134  
RECOMMENDED WIRING DIAGRAM  
SERIES 125 BOOSTER PUMP CONTROL VALVES**

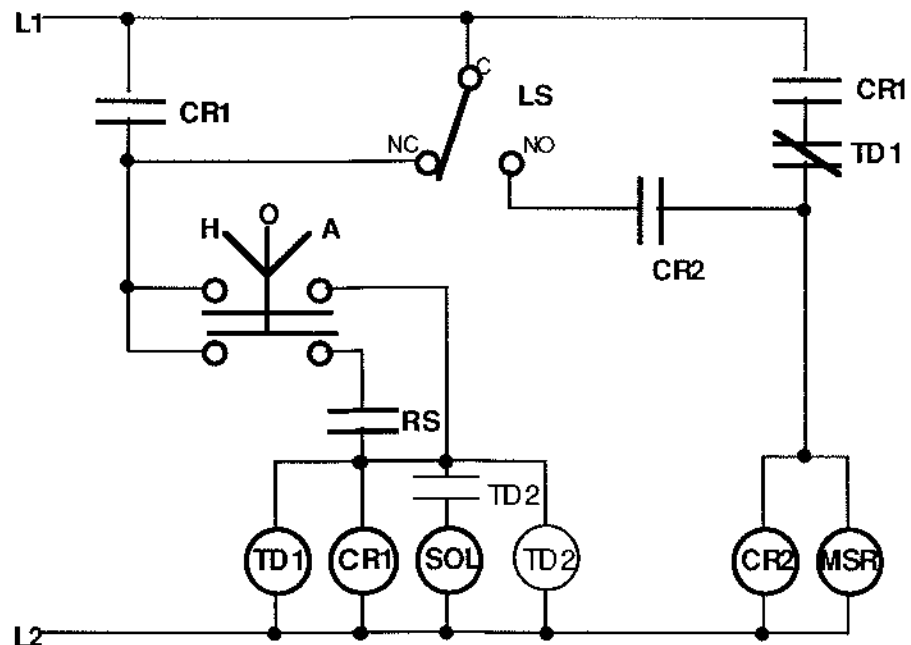

**FURNISHED BY OCV:**

- SOL = Solenoid Pilot Valve
- LS = Limit Switch, SPDT

**FURNISHED BY CUSTOMER:**

- HOA = Hand-Off-Auto Switch
- RS = Remote Start Switch (for Automatic Operation)
- CR1 = Control Relay, DPST, N.O. or better
- CR2 = Control Relay, SPST, N.O. or better
- TD1 = Time Delay Relay, On-Delay Type, SPST, N.C. or better (Shuts down pump if valve does not open) 0-180 secs. recommended
- TD2 = Time Delay Relay, On-Delay Type, SPST, N.O. or better (OPTIONAL: Delays valve opening after pump start.)
- MSR = Pump Motor Starter Relay

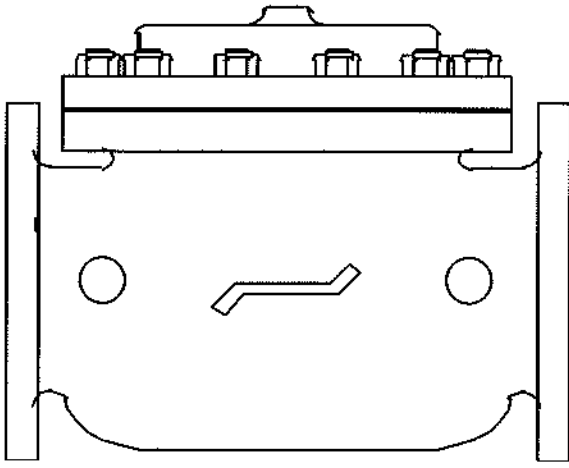

## installation, operating, and maintenance instructions

# series 65

## basic control valve

### GENERAL DESCRIPTION

The OCV Series 65 is a hydraulically-operated, diaphragm-actuated valve. It is available in either a globe (Model 65) or angle (Model 65A) configuration. The diaphragm is nylon-fabric bonded with synthetic rubber and forms a sealed chamber in the upper portion of the valve, separating operating pressure from line pressure. An elastomeric seat disc forms a tight seal with the valve seat when pressure is applied above the diaphragm.

### FUNCTIONAL DESCRIPTION

Because the Series 65 is a hydraulically operated valve, it requires a minimum line pressure of approximately 5 psig in order to function. The valve functions on a simple principle of pressure differential. The line pressure at the inlet of the valve is bypassed through the pilot control piping to the diaphragm chamber of the valve. This pressure, together with the valve spring, works against the pressure under the valve seat. Because the effective area of the diaphragm is greater than that of the seat, the valve is held tightly closed. As the controlling pilot(s) allow the pressure to bleed off the diaphragm chamber, the two opposing pressures begin to balance and the valve will begin to open. The valve can be used to perform a simple on-off function, or with the proper pilot system, a modulating, or regulating function.

In cases where the line fluid is unusually dirty, or is otherwise unsuitable for operating the valve, an independent operating pressure source may be employed. The pressure available from such a source must be equal to, or greater than, line pressure.

### INSTALLATION

In order to insure safe, accurate and efficient operation of the OCV control valve, the following list of checkpoints and procedures should be followed when installing the

valve.

1. Make a careful visual inspection of the valve to insure that there has been no damage to the external piping, fittings or controls. Check that all fittings are tight.
2. Thoroughly flush all interconnecting piping of chips, scale and foreign matter prior to mounting the valve.
3. Install the valve in the line according to the flow arrow on the inlet flange. The arrow should point downstream.
4. Allow sufficient room around the valve for ease of adjustment and maintenance service.

In addition, it is highly recommended that:

1. Isolation valves (eg., gate or butterfly) be installed on the inlet and discharge sides of the valve to facilitate isolating the valve for maintenance.
2. Pressure gauges be installed at the inlet and outlet sides of the valve to provide monitoring of the valve during initial start-up and during operation. The body side ports, if unused by the pilot system, provide a convenient connection for the gauges.
3. All valves larger than 6" be installed horizontally, i.e., with the bonnet pointed up, for ease of adjustment and maintenance servicing.

### MAINTENANCE

The OCV control valve requires no lubrication and a minimum of maintenance. However, a periodic inspection should be established to determine how the fluid being handled is affecting the efficiency of the valve. In a water system, for example, the fluid velocity as well as the substances occurring in natural waters, such as dissolved minerals and suspended particles, vary in every installation. The effect of these actions or substances must be determined by inspection. It is recommended that an annual inspection, which includes ex-

amination of the valve interior, be conducted. Particular attention should be paid to the elastomeric parts, i.e., the diaphragm and seat disc. Any obviously worn parts should be replaced.

### REPAIR PROCEDURES

In the event of malfunction of the OCV control valve, troubleshooting should be conducted according to the procedures outlined for the specific model of valve. Then, if those steps indicate a problem with the main valve, this section will outline the procedures necessary to correct the problem.

Problems with the main valve can be classed in three basic categories:

1. VALVE FAILS TO OPEN
  - a. Diaphragm damaged\* - See Procedure A
  - b. Stem binding - See Procedure B
2. VALVE FAILS TO CLOSE
  - a. Diaphragm damaged\* - See Procedure A
  - b. Stem binding - See Procedure B
  - c. Object lodged in valve - See Procedure B
3. VALVE OPENS AND CLOSES BUT LEAKS WHEN CLOSED
  - a. Seat disc damaged - See Procedure C
  - b. Seat ring damaged - See Procedure D

*\*A diaphragm failure can prevent the valve from either opening or closing, depending on the flow direction. Most water service valves flow "under the seat", in which case a diaphragm failure will keep the valve from closing. On the other hand, most fuel service valves flow "over the seat", in which case a diaphragm failure will keep the valve from opening. To determine which you have, examine the bridge mark cast into the side of the valve body, then compare it with the figures below.*

#### PROCEDURE A : DIAPHRAGM REPLACEMENT

1. Isolate the valve from the system by closing upstream and downstream block valves.
2. Loosen one of the tubing connections on the bonnet. Allow any residual pressure to bleed off.
3. Remove all tubing connected at the bonnet.
4. Remove the bonnet nuts.
5. Remove the bonnet. If the bonnet sticks in place, it may be loosened by rapping sharply around its edge with a rubber-headed mallet. *NOTE: 8" and larger valves are equipped with eye bolts through which a chain can be fastened to aid in*

- lifting the bonnet.*
6. Remove the spring.
  7. Remove the diaphragm plate capscrews and the diaphragm plate.
  8. Remove the old diaphragm.
  9. Making sure the dowel pin holes are in the proper location, place the new diaphragm over the studs and press down until it is flat against the body and spool.
  10. Replace the diaphragm plate and the diaphragm plate capscrews.
  11. Tighten all diaphragm plate capscrews snugly.
  12. Replace the spring.
  13. Replace the bonnet and reinstall the bonnet nuts.
  14. Tighten the bonnet nuts snugly using a criss-cross tightening pattern.
  15. Reinstall the control tubing.
  16. Reopen the upstream and downstream block valves.
  17. Before placing the valve back in service, perform the air bleed procedure described in the first section of this manual.

#### PROCEDURE B: CORRECTION OF BINDING STEM

1. Perform Steps 1 thru 6 of Procedure A, above.
2. Remove the spool assembly from the valve. *NOTE:*

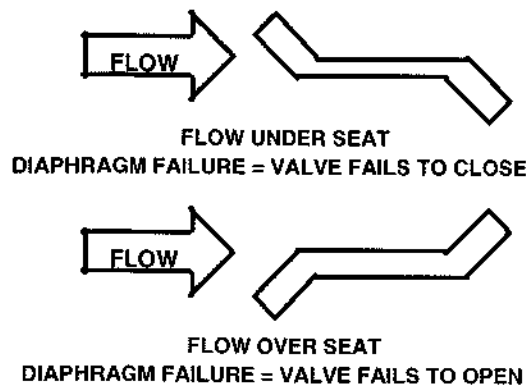

*On smaller valves, this can be accomplished simply by grasping the stem and pulling upward. Valves 6" and larger have the top of the stem threaded to accept an eyebolt to aid in lifting the spool out of the body. 6" thru 12" valves are threaded 3/8-16. 14" and 16" valves are threaded 5/8-11.*

3. Carefully examine both ends of the stem for deep scratches, scoring or buildup of mineral deposits.

- Polish the stem if necessary using a fine grade of emery cloth.
- 4. Similarly, examine and polish the upper bushing (in the bonnet) and the lower guide (in the seat ring).
- 5. Reinstall the spool assembly.
- 6. Reassemble the valve, following Steps 12 thru 17 in Procedure A.

**PROCEDURE C: SEAT DISC REPLACEMENT**

1. Perform Steps 1 and 2 of Procedure B, above.
2. With the spool assembly removed from the body, remove the seat retainer screws.
3. Slide the seat retainer off the lower end of the stem.
4. Remove the seat disc from its groove in the spool.  
*NOTE: The seat disc may fit quite tightly in the groove. If necessary, it may be pried out using a thin-bladed screwdriver or similar tool.*
5. Install the new seat disc in the groove.
6. Reinstall the seat retainer and tighten the seat retainer screws.
7. Reassemble the valve, following Steps 5 and 6 of Procedure B.

**PROCEDURE D: SEAT RING REPLACEMENT**

*NOTE: It is rare for a seat ring to require replacement. Minor nicks and scratches in the seating surface can usually be smoothed out with emery cloth.*

1. Perform Steps 1 and 2 of Procedure B, above.
2. If you are working on a 4" or smaller valve, follow Steps 3 thru 9, below.
3. If you are working on a 6" or larger valve, follow Steps 10 thru 16, below.

4. Seat rings in valves 4" and smaller are threaded into the valve body. To remove, you will need a special seat ring tool. You may fabricate one using standard pipe as shown in the sketch below, or one may be purchased from OCV.
5. Using the seat ring tool, unthread the seat ring from the body.
6. Remove the old o-ring from the counterbore in the body.
7. Install the new o-ring in the counterbore.
8. Using the seat ring tool, install the new seat ring.
9. Reassemble the valve, following Steps 5 & 6 of Procedure B.
10. Seat rings in valves 6" and larger are bolted into the body with socket head capscrews. In addition you will note that the seat ring is equipped with additional threaded holes that may be used for "jacking" the seat ring out of the body.
11. Remove the socket head capscrews.
12. Remove the old seat ring from the body by temporarily installing two or more of the capscrews in the "jacking" holes.
13. Install a new o-ring in the groove of the new seat ring. Lubricate the o-ring and outer seat ring wall with Vaseline® or similar lubricant.
14. Install the new seat ring in the body, making sure that the capscrew holes line up.
15. Replace and tighten all the capscrews.
16. Reassemble the valve, following Steps 5 and 6 of Procedure B.

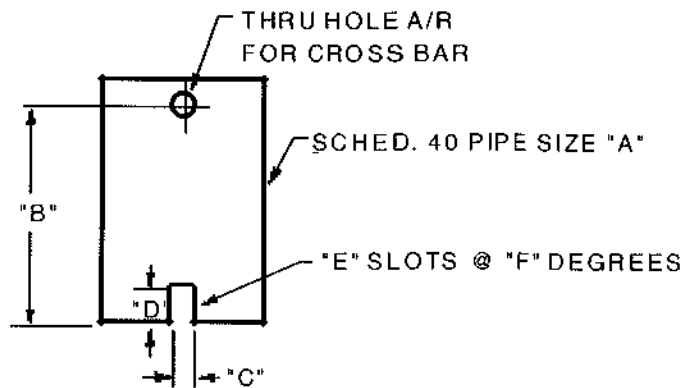

VALVE SIZE	"A" PIPE SIZE	"B" MIN. LENGTH	"C" SLOT WIDTH	"D" SLOT DEPTH	"E" NO. OF SLOTS	"F" SLOT SPACING
1-1/4"	3/4"	6"	3/8"	3/8"	2	180°
1-1/2"	3/4"	6"	3/8"	3/8"	2	180°
2"	1-1/2"	7"	3/8"	3/8"	2	180°
2-1/2"	2"	8"	1/2"	1/2"	3	120°
3"	2-1/2"	9"	5/8"	5/8"	2	180°
4"	3"	10"	5/8"	5/8"	2	180°

REVISED 3-17-97



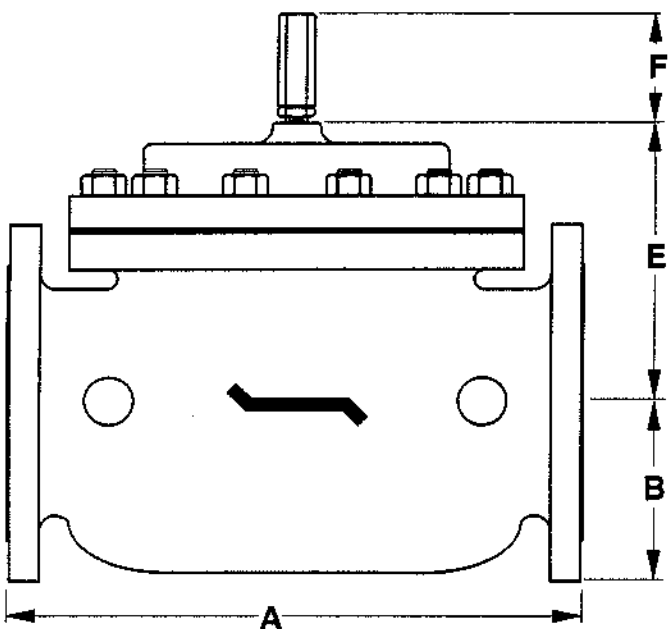
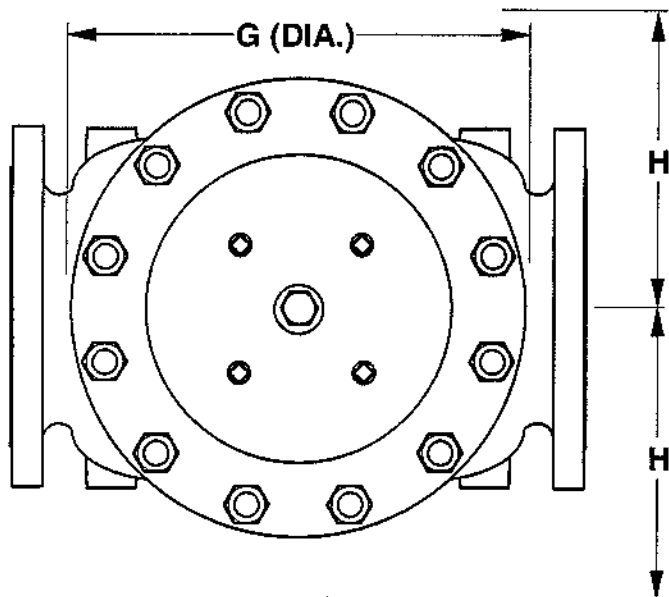

DIM	ANSI CLASS	VALVE SIZE												
		1 1/4	1 1/2	2	2 1/2	3	4	6	8	10	12	14	16	24
A	SE	8.75	8.75	9.88	10.50	13.00	-	-	-	-	-	-	-	-
	150	8.50	8.50	9.38	10.50	12.00	15.00	17.75	25.38	29.75	34.00	39.00	40.38	62.00
	300	8.75	8.75	9.88	11.12	12.75	15.62	18.62	26.38	31.12	35.50	40.50	42.00	63.75
B	SE	1.44	1.44	1.69	1.88	2.25	-	-	-	-	-	-	-	-
	150	2.31	2.50	3.00	3.50	3.75	4.50	5.50	6.75	8.00	9.50	10.62	11.75	16.00
	300	2.62	3.06	3.25	3.75	4.12	5.00	6.25	7.50	8.75	10.25	11.50	12.75	18.00
C	SE	4.38	4.38	4.75	6.00	6.50	-	-	-	-	-	-	-	-
	150	4.25	4.25	4.75	6.00	6.00	7.50	10.00	12.69	14.88	17.00	-	20.81	-
	300	4 3/8	4.38	5.00	6.38	6.38	7.81	10.50	13.19	15.56	17.75	-	21.62	-
D	SE	3.12	3.12	3.88	4.00	4.50	-	-	-	-	-	-	-	-
	150	3.00	3.00	3.88	4.00	4.00	5.50	6.00	8.00	11.38	11.00	-	15.69	-
	300	3.25	3.25	4.12	4.38	4.38	5.81	6.50	8.50	12.06	11.75	-	16.50	-
E	ALL	6.00	6.00	6.00	7.00	6.50	7.92	10.00	11.88	15.38	17.00	18.00	19.00	27.00
F	ALL	3.88	3.88	3.88	3.88	3.88	3.88	3.88	6.38	6.38	6.38	6.38	6.38	8.00
G	ALL	6.00	6.00	6.75	7.69	8.75	11.75	14.00	21.00	24.50	28.00	31.25	34.50	52.00
H	ALL	10.00	10.00	11.00	11.00	11.00	12.00	13.00	14.00	17.00	18.00	20.00	20.00	28.50

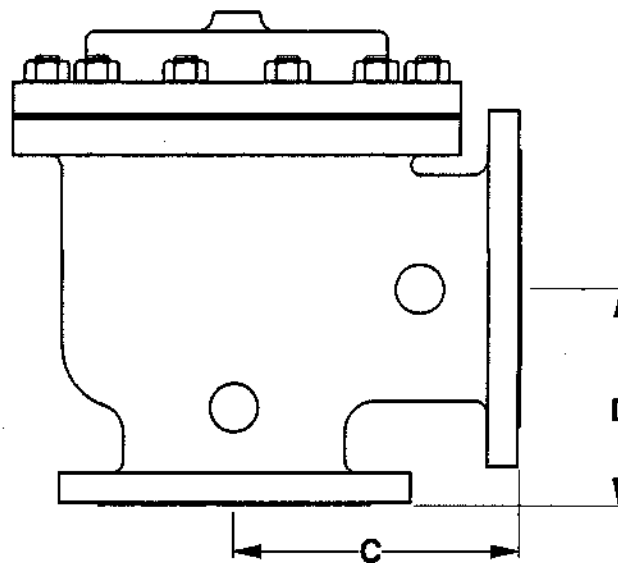

NOTE: 3" VALVE DIMENSIONS  
ARE FOR NEW MODEL 3100

4" VALVE DIMENSIONS ARE FOR  
NEW MODEL 4400

REV. A SDJ 6-6-02  
REV. B SDJ 2-3-03

<b>TOLERANCES</b> UNLESS NOTED FRACTIONAL $\pm 1/64$ DECIMAL $\pm .005$ MACH. FINISH 125/ $\sqrt{\text{ }}$ ANGULAR $\pm 1/2^\circ$		 <b>OCV Control Valves</b> TULSA, OKLAHOMA U.S.A.	
<b>GENERAL VALVE DIMENSIONS</b>			
DRAWN BY SDJ	DATE 10-6-97	SIZE <b>A</b>	DRAWING NUMBER <b>65D</b>
CHKD. BY	DATE	REV. <b>B</b>	

# INSTALLATION & MAINTENANCE INSTRUCTIONS

**ASCO.**

BULLETIN

8320

3-WAY SOLENOID VALVES — NORMALLY OPEN,  
NORMALLY CLOSED, AND UNIVERSAL OPERATION  
1/4" NPT — BRASS AND STAINLESS STEEL CONSTRUCTION

Form No. V5688R 2

## DESCRIPTION

Bulletin 8320 valves are small 3-way solenoid valves with all three connections located in the body. Valve bodies are made of brass or stainless steel.

Standard valves have a Type I, General Purpose Solenoid Enclosure. Valves may also be provided with an explosion-proof solenoid enclosure designed to meet Enclosure Type 3-Raintight, Type 7 (C & D)-Explosion-Proof Class I, Groups C & D and Type 9 (E, F, & G)-Dust Ignition-Proof Class II, Groups E, F, & G, and have a temperature range code of TC3. Installation and maintenance instructions for the explosion-proof solenoid enclosure are on Form No. V5380.

## OPERATION

**Normally Open (Pressure at 3)**

Applies pressure when solenoid is de-energized; exhausts pressure when solenoid is energized. When solenoid is de-energized, flow is from Port "3" to Port "1." Port "2" is closed. When solenoid is energized, flow is from Port "1" to "2." Port "3" is closed.

**Normally Closed (Pressure at 2)**

Applies pressure when solenoid is energized; exhausts pressure when solenoid is de-energized. When solenoid is de-energized, flow is from Port "1" to Port "3." Port "2" is closed. When solenoid is energized, flow is from Port "2" to Port "1." Port "3" is closed.

**Universal (Pressure at 1, 2, or 3)**

For normally closed or normally open operation, selection or diversion of pressure can be applied to Ports "1", "2", or "3."

## Temperature Limitations

For maximum valve ambient and fluid temperatures, refer to chart below. Check catalog number prefix and watt rating on nameplate to determine the maximum temperatures. See example below chart.

Construction AC or DC	Catalog Number Prefix	Watts	Maximum Ambient Temp. °F	Maximum Fluid Temp. °F
AC	None, DA, or S	10.5	77	200
	DF, FT, or SF	10.5	122	200
	HT	10.5	140	200
DC	None, DP, or SP	16.7*	77	200
	None, FT, or HT	11.2*	77	150

\* Catalog Nos. 8320A 170, 8320A 180, and 8320A 190 are limited to 140 °F fluid temperature.

**EXAMPLES:** For Catalog No. HT8320A 201, AC construction with a watt rating of 10.5, the maximum ambient temperature is 140°F with a maximum fluid temperature of 200°F. For Catalog No. 8320A 204, AC construction with a watt rating of 10.5, the maximum ambient temperature is 77°F with a maximum fluid temperature of 200°F.

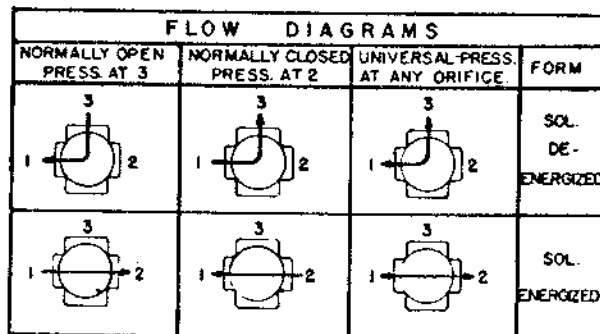

## Manual Operator (Optional)

Manual operator allows manual operation when desired or during an electrical power outage. Two types of manual operators are available - push type (Suffix MO) and screw type (Suffix MS). To operate valve manually with push type operator, push stem at base of valve body as far upward as possible. Valve will now be in the same position as when the solenoid is energized. Removing pressure from stem will release manual operator to original position. To operate valve with a screw type manual operator, rotate manual operator stem at base of valve body clockwise until it hits a stop. Valve will now be in the same position as when the solenoid is energized. Rotate manual operator stem fully counterclockwise before operating valve electrically.

## INSTALLATION

Check nameplate for correct catalog number, pressure, voltage, frequency, and service.

## Positioning

This valve is designed to perform properly when mounted in any position. However, for optimum life and performance, the solenoid should be mounted vertically and upright to reduce the possibility of foreign matter accumulating in the solenoid base sub-assembly area.

## Mounting

For mounting dimensions of body boss (brass) or mounting brackets (optional on brass construction), refer to Figures 1, 2, and 3.

## Piping

Connect piping to valve according to markings on valve body. Refer to flow diagrams provided. Apply pipe compound sparingly to male pipe threads only. If applied to valve threads, the compound may enter the valve and cause operational difficulty. Avoid pipe strain by properly supporting and aligning piping. When tightening the pipe, do not use valve or solenoid as a lever. Locate wrenches applied to valve body or piping as close as possible to connection point.

**IMPORTANT:** To protect the solenoid valve, install a strainer or filter, suitable for the service involved in the inlet side as close to the valve as possible. Clean periodically depending on service conditions. See ASCO Bulletins 8600, 8601, and 8602 for strainers.

## Wiring

Wiring must comply with local codes and the National Electrical Code. Solenoid housings are provided with a 7/8" diameter hole to accommodate 1/2" conduit. On some constructions, a green grounding wire is provided. Use rigid metallic conduit to ground all enclosures not provided with a green grounding wire. To facilitate wiring, the enclosure may be rotated 360° by removing the retaining cap or clip. **WARNING:** When metal retaining clip disengages, it will spring upward. Rotate enclosure to desired position. Then replace retaining cap or clip before operating.

**NOTE:** Alternating current (AC) and direct current (DC) solenoids are built differently. To convert from one to the other, it is necessary to change the complete solenoid, including the solenoid base sub-assembly and core assembly.

Form No. V5688R 2

**ASCO Valves**

**ASCO**

Printed in U.S.A.

Automatic Switch Co. 50-60 Hanover Road, Florham Park, New Jersey 07932

© Automatic Switch Co. MCN-111111. All Rights Reserved.

### Solenoid Temperature

Standard catalog valves are supplied with coils designed for continuous duty service. When the solenoid is energized for a long period, the solenoid enclosure becomes hot and can be touched by hand only for an instant. This is a safe operating temperature. Any excessive heating will be indicated by the smoke and odor of burning coil insulation.

### MAINTENANCE

NOTE: It is not necessary to remove the valve from the pipeline for repairs.  
WARNING: Turn off electrical power supply and depressurize valve before making repairs.

### Cleaning

All solenoid valves should be cleaned periodically. The time between cleanings will vary depending on the medium and service conditions. In general, if the voltage to the coil is correct, sluggish valve operation, excessive noise, or leakage will indicate that cleaning is required. Clean valve strainer or filter when cleaning the valve.

### Preventive Maintenance

1. Keep the medium flowing through the valve as free from dirt and foreign material as possible.
2. While in service, the valve should be operated at least once a month to insure proper opening and closing.
3. Depending on the medium and service conditions, periodic inspection of internal valve parts for damage or excessive wear is recommended. Thoroughly clean all parts. Replace worn or damaged parts. However, for best results, replace all parts as supplied with an ASCO Rebuild Kit.

### Causes Of Improper Operation

1. **Faulty Control Circuits:** Check the electrical system by energizing the solenoid. A metallic "click" signifies that the solenoid is operating. Absence of the "click" indicates loss of power supply. Check for loose or blown fuses, open circuited or grounded coil, broken lead wires or splice connections.
2. **Burned-Out Coil:** Check for open-circuited coil. Replace coil as necessary. Check supply voltage; it must be the same as specified on nameplate.
3. **Low Voltage:** Check voltage across the coil lead. Voltage must be at least 85% of nameplate rating.
4. **Incorrect Pressure:** Check valve pressure. Pressure to valve must be within range specified on nameplate.
5. **Excessive Leakage:** Disassemble valve (see Maintenance) and clean all parts. Replace worn or damaged parts. However, for best results, replace all parts as supplied with an ASCO Rebuild Kit.

### Coil Replacement (Refer to Figures 4 and 5)

WARNING: Turn off electrical power supply.

1. Disconnect coil lead wires.
2. Remove retaining cap or clip, nameplate and housing. WARNING: When metal retaining clip disengages, it will spring upward.
3. Remove spring washer, insulating washer, coil, insulating washer, ground wire terminal (if present) from solenoid base sub-assembly. Insulating washers are omitted when a molded coil is used.
4. Reassemble in reverse order of disassembly. Use exploded view provided for identification and placement of parts.

CAUTION: The solenoid must be fully reassembled because the housing and internal parts complete the magnetic circuit. Be sure to replace insulating washer at each end of the non-molded coil.

### Valve Disassembly (Refer to Figures 4 and 5)

WARNING: Depressurize valve and turn off electrical power supply.

1. Disassemble valve in an orderly fashion. Use exploded views for identification and placement of parts.
2. If necessary, disconnect coil lead wires, grounding wire (if present), and rigid conduit from solenoid housing.
3. Remove retaining cap or clip and slip the entire solenoid enclosure off the solenoid base sub-assembly. WARNING: When metal retaining clip disengages, it will spring upward.
4. Unscrew solenoid base sub-assembly from valve body.
5. Remove core assembly, core spring, core guide (AC construction only), and solenoid base gasket.
6. Unscrew end cap (or manual operator assembly) and remove end cap gasket, disc holder spring, and disc holder sub-assembly.
7. All parts are now accessible to clean or replace. Replace worn or damaged parts. However, for best results, replace all parts as supplied with an ASCO Rebuild kit.

### Valve Reassembly

1. Reassemble in reverse order of disassembly. Use exploded views for identification and placement of parts.
2. Lubricate all gaskets with DOW CORNING® 111 Compound lubricant or an equivalent high-grade silicone grease. For stainless steel valve constructions, apply a small amount of LOCTITE® PST® pipe sealant (ASCO No. 208-832-11) to male threads of end cap (or manual operator assembly). Pipe sealant supplied in ASCO Rebuild Kits.

3. Replace disc holder sub-assembly, disc holder spring, end cap gasket, and end cap (or manual operator assembly). For brass construction, torque end cap to  $175 \pm 25$  inch-pounds ( $19.8 \pm 2.8$  newton-meters). For stainless steel, torque end cap to  $90 \pm 10$  inch-pounds ( $10.2 \pm 1.1$  newton-meters).
4. Replace solenoid base gasket, core assembly, core spring, core guide (on AC construction only), and solenoid base sub-assembly. Torque solenoid base sub-assembly to  $175 \pm 25$  inch-pounds ( $19.8 \pm 2.8$  newton-meters).
5. Replace solenoid enclosure and retaining cap or clip.
6. Restore line pressure and electrical power supply to valve.
7. After maintenance is completed, operate the valve a few times to be sure of proper operation. A metallic "click" signifies the solenoid is operating.

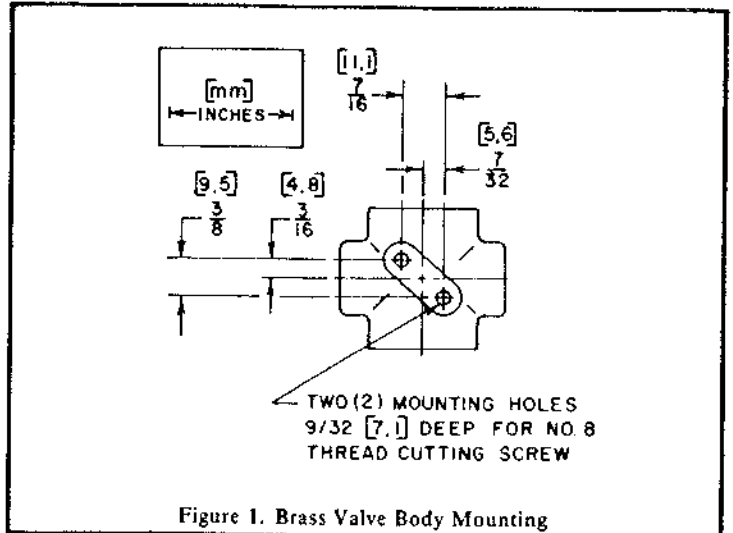

Figure 1. Brass Valve Body Mounting

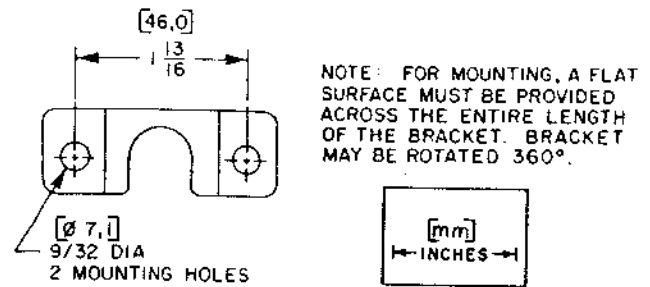

Figure 2. Mounting Bracket for Stainless Steel

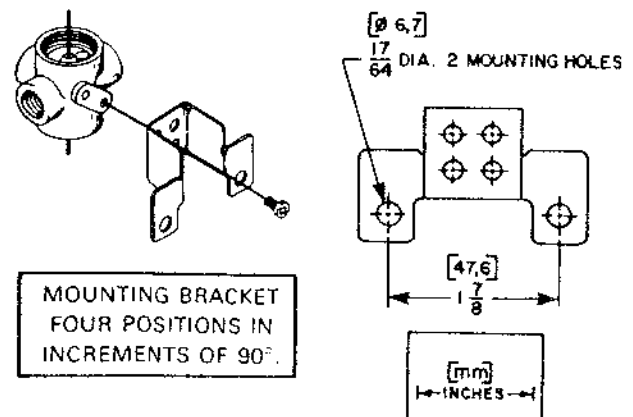

Figure 3. Optional Mounting Bracket for Brass

**ORDERING INFORMATION  
FOR ASCO REBUILD KITS AND COILS**

Parts marked with an asterisk (\*) in the exploded view are supplied in Rebuild Kits.

- When Ordering Rebuild Kits for ASCO valves, order the Rebuild Kit number stamped on the valve nameplate. †
  - When Ordering Coils for ASCO valves, order the number stamped on your coil. †
- † If the number of the Rebuild Kit or the Coil is not visible, order them and specify your valve's Catalog Number, Serial Number, Voltage, and Frequency.

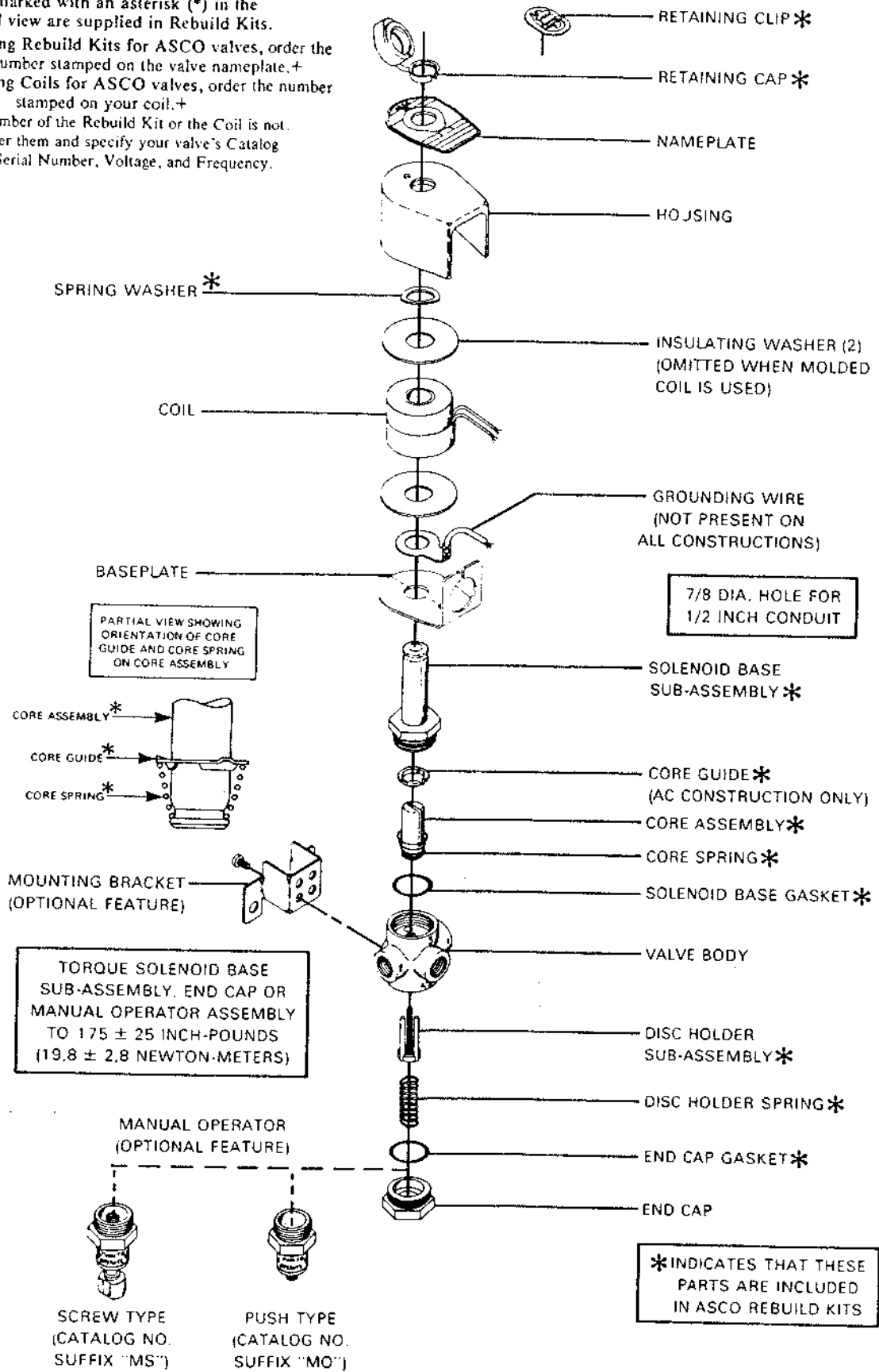
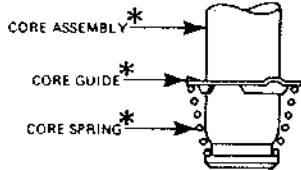

Figure 4. Bulletin 8320, Brass Construction  
With General Purpose Solenoid Enclosure Shown  
For Explosion-Proof Solenoid Enclosure, See Form No. V5380.

TORQUE SOLENOID BASE  
SUB-ASSEMBLY TO  
175 ± 25 INCH-POUNDS  
(19.8 ± 2.8 NEWTON-METERS)



TORQUE END CAP OR  
MANUAL OPERATOR ASSEMBLY  
TO 90 ± 10 INCH-POUNDS  
(10.2 ± 1.1 NEWTON-METERS)

\*INDICATES THAT THESE  
PARTS ARE INCLUDED  
IN ASCO REBUILD KITS

RETAINING CLIP \*

RETAINING CAP \*

NAMEPLATE

HOUSING

SPRING WASHER \*

COIL

GROUNDING WIRE  
(NOT PRESENT ON  
ALL CONSTRUCTIONS)

BASEPLATE

SOLENOID BASE  
SUB-ASSEMBLY \*

7/8 DIA. HOLE FOR  
1/2 INCH CONDUIT

CORE GUIDE \*  
(AC CONSTRUCTION ONLY)

CORE ASSEMBLY \*

CORE SPRING \*

SOLENOID BASE GASKET \*

VALVE BODY

DISC HOLDER  
SUB-ASSEMBLY \*

MOUNTING BRACKET

DISC HOLDER SPRING \*

END CAP GASKET \*

END CAP

MANUAL OPERATOR  
(OPTIONAL FEATURE)

PUSH TYPE  
(CATALOG NO.  
SUFFIX "MO")

SCREW TYPE  
(CATALOG NO.  
SUFFIX "MS")

Figure 5. Bulletin 8320, Stainless Steel Construction  
With General Purpose Solenoid Enclosure Shown.  
For Explosion-Proof Solenoid Enclosure, See Form No.V5380.



**ASCO Valves**

Automatic Switch Co. 50-60 Hanover Road, Florham Park, New Jersey 07932

Form No. V5688R2

Printed in U.S.A.

© Automatic Switch Co. W0112201. All Rights Reserved.

# accelerator pilot

# installation, operating, and maintenance instructions

## model A224

### GENERAL DESCRIPTION

The OCV Model A224 Accelerator Pilot is a hydraulically-operated, diaphragm-type three-way valve. It has two operating positions, one which provides full flow between two of its ports. It is normally used on a main valve subject to the following conditions: (1) A modulating-type pilot, such as rate of flow, is also used on the valve; (2) Faster-than-normal closing speed is required; and (3) An independent means, such as a solenoid pilot or float valve, is used to place the valve in or out of operation.

### INSTALLATION

Referring to the attached assembly drawing for port identification, the A224 is installed on the main valve as follows: Port A is connected to the control pilot. Port B is connected to the bonnet of the main valve. Port D is connected to the energizing source (solenoid or float pilot).

### THEORY OF OPERATION

Pressurizing the bonnet of the A224 pilot through Port D moves the stem assembly to its downward position. Orificed flow is now available from Port C (main valve inlet) to both Port A (Control pilot) and Port B (Main valve bonnet). In this position, the A224 acts as an ejector. Flow through it is modulated by the control pilot, which in turn modulates the main valve to maintain a constant flow rate or pressure.

When pressure is removed from the bonnet of the A224, pressure at Port C forces the stem assembly to its upward position. Now Port A (Control pilot) is blocked, and full flow is available from Port C (main valve inlet) to Port B (main valve bonnet). The main valve thus goes quickly closed.

### MAINTENANCE

Because of the simplicity of design of the A224 pilot, required maintenance is minimal. Check fittings and bolts periodically for tightness, and inspect the body for damage or excessive buildup of foreign material.

### TROUBLESHOOTING

A major malfunction in the A224 pilot would generally be evident in a failure of the main valve to open or close. However, keep in mind that such symptoms can be also caused by a malfunction in the main valve itself or in the control pilot(s). If the A224 is suspected, proceed as follows:

#### A. FAILURE OF PILOT TO OPEN MAIN VALVE

1. Ruptured diaphragm:
  - (a) Detach sense line from the bonnet of the pilot and remove the bonnet. Inspect the diaphragm carefully for holes or cracks.
  - (b) If damaged, replace with new diaphragm.
2. Pilot stem binding:
  - (a) With bonnet removed, inspect the stem journal in the bonnet for buildup of foreign material.
  - (b) Clean as necessary and reassemble pilot.
3. Obstruction in seat area: Disassemble pilot and remove obstruction.
4. Rubber seat damaged:
  - (a) Disassemble pilot and examine seats for excessive wear or damage.
  - (b) Replace if necessary and reassemble pilot.

#### B. FAILURE OF PILOT TO CLOSE MAIN VALVE

1. Pilot stem binding - Proceed as in A2, above.
2. Obstruction in seat area - Proceed as in A3, above.
3. Rubber seat damaged - Proceed as in A4, above.

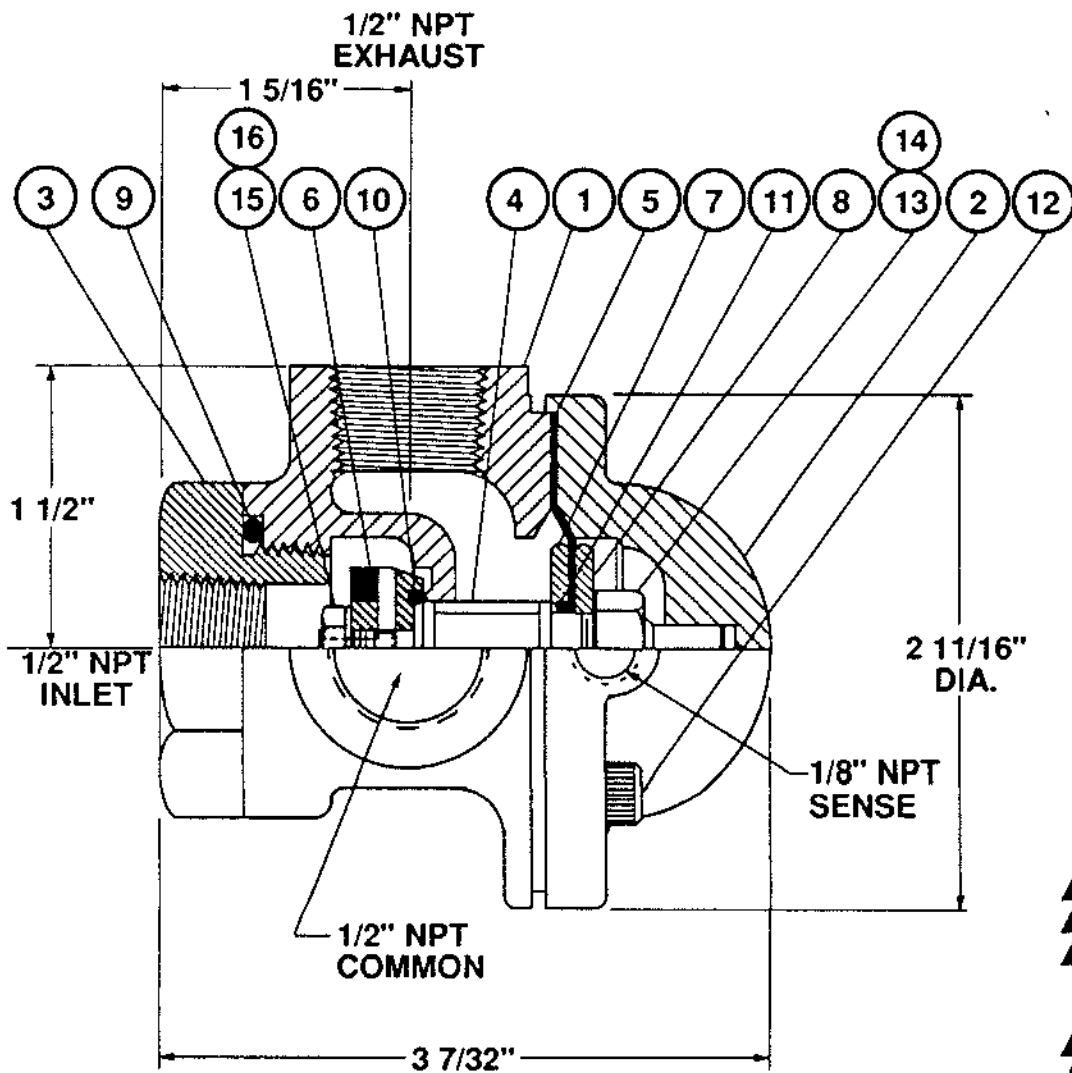

▲ = RECOMMENDED SPARE PARTS

ITEM	PART NO	QTY	DESCRIPTION	MATERIAL
16	685720	1	LOCKWASHER	STN. STEEL
15	590718	1	HEX NUT	STN. STEEL
14	685702	1	LOCKWASHER	STN. STEEL
13	590717	1	HEX NUT	STN. STEEL
12	530708	4	SKT. HD. CAPSCREW	STN. STEEL
▲ 11	611012	1	O-RING	VITON
▲ 10	611111	1	O-RING	VITON
▲ 9	610216	1	O-RING	BUNA-N
8	308110	1	UPPER DIAPH. PLATE	BRASS
7	308109	1	LOWER DIAPH. PLATE	BRASS
▲ 6	310708	1	SEAT PLUG	SS/BUNA-N
▲ 5	694000	1	DIAPHRAGM	BUNA-N
4	314732	1	STEM	STN. STEEL
3	300782	1	ADAPTER	STN. STEEL
2	304100	1	BONNET	BRONZE
1	302100	1	BODY	BRONZE
ITEM	PART NO	QTY	DESCRIPTION	MATERIAL

REVISIONS				REF DWG NO'S		MATERIAL		TOLERANCES		 <b>OCV Control Valves</b> TULSA, OKLAHOMA U.S.A.		
CHG	E.C. NO.	DATE	BY							<b>ACCELERATOR PILOT</b>		
						NO. REQ'D	DRAWN BY	DATE	SIZE	DRAWING NUMBER	REV.	
						SCALE	SDJ	2-2-93	<b>A</b>	<b>A224</b>		
							CHRD. BY	DATE				

UNLESS NOTED  
 FRACTIONAL ±1/64  
 DECIMAL ±.005  
 MACH. FINISH 125  
 ANGULAR ±1/2°

# three-way pilot

## installation, operating, and maintenance instructions

# model 3600

### GENERAL DESCRIPTION

The OCV Model 3600 is a hydraulically-operated, diaphragm-actuated, three-way valve. It is normally used on a main valve when faster-than-normal closing speed is required or when another pilot (e.g., float pilot or solenoid valve) is used to actuate the main valve.

### FUNCTIONAL DESCRIPTION

Pressurizing the bonnet of the three-way pilot moves its stem to the "down" position connecting Ports 1 and 3. Depressurizing the bonnet of the OCV Model 3600 allows its stem to return to the "up position," connecting Ports 1 and 2.

Pressurize the bonnet of the 3600 to open the main valve on Model 115-4's, 125's and 119's. De-pressurize the bonnet of the 3600 to open the main valve on Model 3333's and 118's.

### TROUBLESHOOTING

A major malfunction in the three-way pilot would generally be evident in a failure of the main valve to open or close. However, keep in mind that such symptoms can also be caused by a malfunction in the main valve itself or in the control pilot(s). If the 3600 is suspected, proceed as follows:

#### 1. FAILURE OF PILOT TO CLOSE MAIN VALVE

##### A. Ruptured diaphragm

- (1) Detach sense line from the bonnet of the pilot and remove the bonnet. Inspect the

diaphragm carefully for holes or cracks.

- (2) If damaged, replace with new diaphragm.

##### B. Pilot stem binding

- (1) With bonnet removed, inspect the stem journal in the bonnet for buildup of foreign material.
- (2) Clean as necessary and reassemble pilot.

##### C. Obstruction in seat area

- (1) Disassemble pilot and remove obstruction.

##### D. Rubber seat damaged

- (1) Disassemble pilot and examine seats for excessive wear or damage.
- (2) Replace if necessary and reassemble pilot.

#### 2. FAILURE OF PILOT TO OPEN MAIN VALVE

##### A. Pilot stem binding

- (1) Proceed as in 1B above.

##### B. Obstruction in seat area

- (1) Proceed as in 1C above.

##### C. Rubber seat damaged

- (1) Proceed as in 1D above.

### MAINTENANCE

Because of the simplicity of design of the 3600 pilot, required maintenance is minimal. Check fittings and bolts periodically for tightness, and inspect the body for damage or excessive buildup of foreign material.



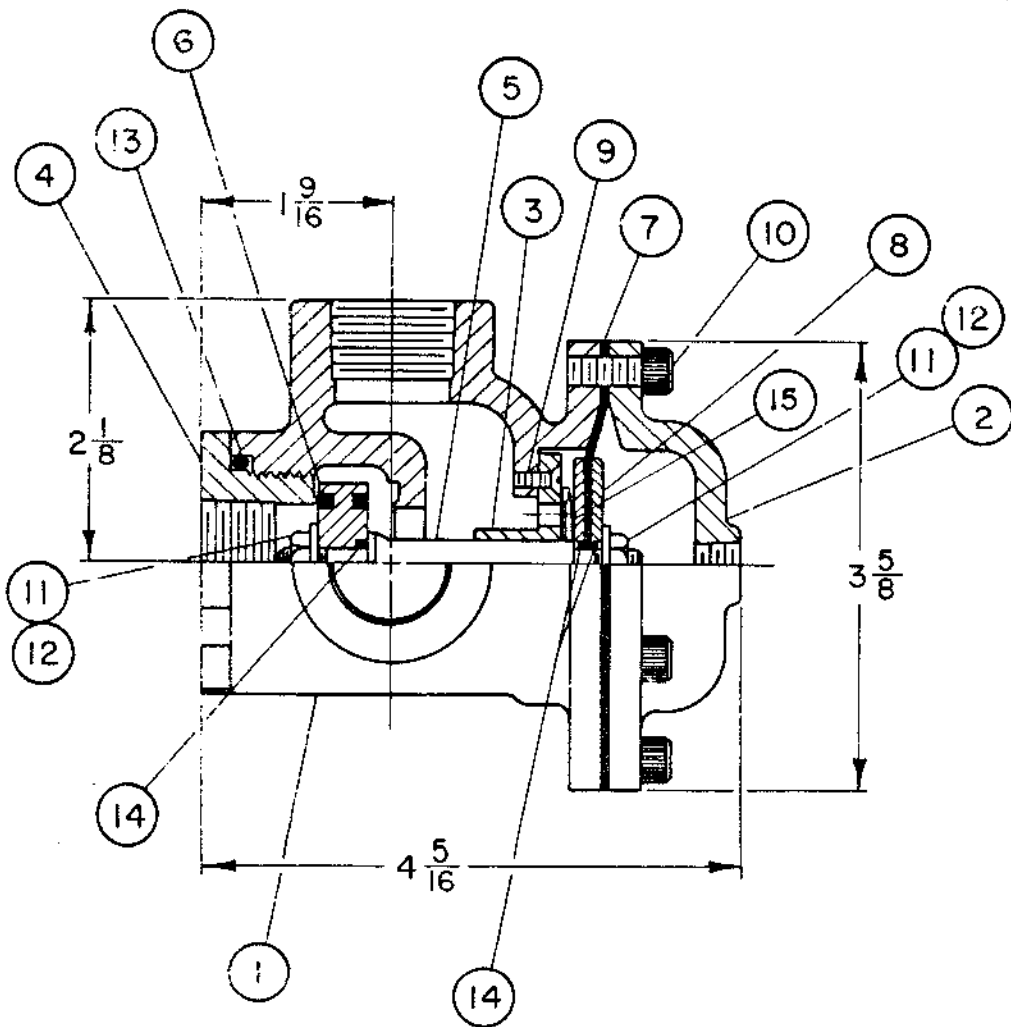

**NOTE:**

1. WHEN ORDERING PARTS, PLEASE SPECIFY; ITEM NO., PART NO. AND MATERIAL.

2. ▲ RECOMMENDED SPARE PARTS.

▲ 15	651717	1	SPRING	STAINLESS STEEL
▲ 14	61010	3	O-RING	VITON
▲ 13	610222	1	O-RING	BUNA-N
▲ 12	685700	2	LOCKWASHER	STAINLESS STEEL
▲ 11	590712	2	HEX HEAD JAM NUT	STAINLESS STEEL
▲ 10	530701	6	SOCKET HD. CAPSCREW	STAINLESS STEEL
▲ 9	532735	2	FLAT HEAD SCREW	STAINLESS STEEL
▲ 8	308135	2	DIAPHRAGM PLATE	BRASS
	308735	2	DIAPHRAGM PLATE	STAINLESS STEEL
▲ 7	694035	1	DIAPHRAGM	BUNA-N
	694135	1	DIAPHRAGM	VITON
▲ 6	310736	1	SEAT DISC	STN. STL./BUNA-N
	310737	1	SEAT DISC	STN. STL./VITON
▲ 5	314735	1	STEM	STAINLESS STEEL
▲ 4	300171	1	ADAPTER	BRASS
	300771	1	ADAPTER	STAINLESS STEEL
▲ 3	300164	1	GUIDE PLATE	BRASS
	300764	1	GUIDE PLATE	STAINLESS STEEL
▲ 2	304135	1	BONNET	BRONZE
	304735	1	BONNET	STAINLESS STEEL
▲ 1	302135	1	BODY	BRONZE
	302735	1	BODY	STAINLESS STEEL
ITEM	PART NO.	QTY.	DESCRIPTION	MATERIAL

**PARTS LIST**

E											
D											
C											
B											
A											
CHG	E	C	NO	DATE	BY						
REVISIONS					REF DWG NO'S						
						<b>MATERIAL</b>	<b>TOLERANCES</b>	<b>MOCV Control Valves</b> <small>TULSA, OKLAHOMA U.S.A.</small> <b>THREE-WAY PILOT</b>			
							UNLESS NOTED FRACTIONAL ± 1/64 DECIMAL ± .008 MACH FINISH 125/ ANGULAR ± 1/2°				
						NO REQ'D	DRAWN BY	DATE	SIZE	DRAWING NUMBER	REV
						SCALE	BRW.	7-28-83	<b>B</b>	<b>3600S</b>	<b>A</b>
							CHKD BY	DATE			



**DESCRIPTION**

The Model 141-3 Flow Control Valve is an adjustable restriction device, installed in the control circuit tubing. The flow control valve differs from a standard needle valve in that it includes an internal check valve. Thus it allows free flow in one direction (through the check) and restricted flow in the other direction (through the needle). The setting of the flow control valve meters the flow into or out of the main valve diaphragm chamber, thus controlling either the opening or closing speed of the main valve. These can be installed in series for separate opening and closing speed control. Restricted flow is in the direction of the flow arrow on the body.

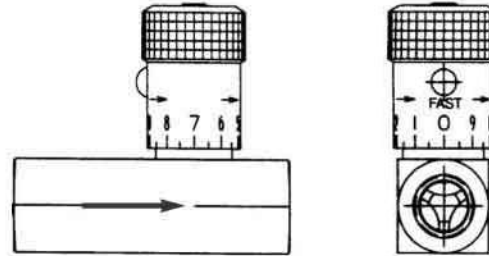

**MODEL 141-3 MATRIX**

MATERIAL	PART NUMBER	INLET/OUTLET (NPT)	A	USED ON VALVE SIZE*
Brass	682100	1/4	2 3/8	1 1/4"-2"
Brass	682101	3/8	2 3/4	2 1/2"-6"
Brass	682102	1/2	3 1/4	8"-10"
Brass	682103	3/4	3 7/8	12"-16"
Stn. Steel	682700	1/4	2 3/8	1 1/4"-2" Stn.
Stn. Steel	682701	3/8	2 3/4	2 1/2"-6"
Stn. Steel	682702	1/2	3 1/4	8"-10"
Stn. Steel	682703	3/4	3 5/8	12"-16"

Note: Flow control valve use and size may vary on valve application. Consult factory.

**SCHEMATIC SYMBOL**

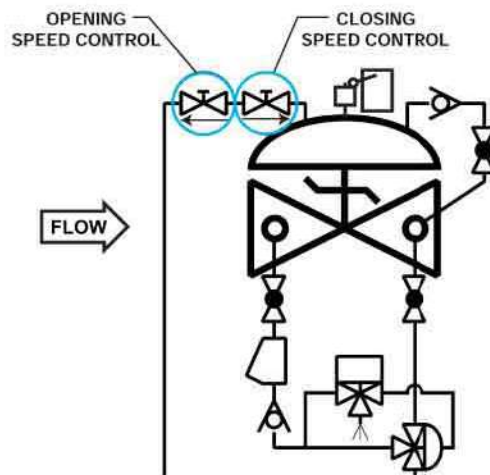

The Model 141-3 Flow Control Valve is shown on OCV Valve Schematics as:

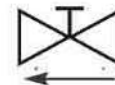

EXAMPLE: Shown here on a MODEL 125 Pump Control Valve as separate opening and closing speeds.

**Flow Control Valves 141-3**

**DESCRIPTION**

The Model 141-1 Check Valve uses a spring-loaded poppet that will allow flow in one direction only. It is the primary component used on valves with a reverse flow check function. Flow is in the direction of the arrow on the check valve body.



◀ Check Valves shown  
Stainless Steel & Brass

**MODEL  
141-1  
MATRIX**

MATERIAL	PART NUMBER	INLET/OUTLET (NPT)	LENGTH	USED ON VALVE SIZE
Bronze	681100	3/8	2	1 1/4"-6"
Bronze	681101	1/2	2 1/8	8"-10"
Bronze	681102	3/4	2 1/4	12"-16"
Stn. Steel	681700	3/8	2 5/16	1 1/4"-6"
Stn. Steel	681701	1/2	2 5/16	8"-10"
Stn. Steel	681702	3/4	2 7/8	12"-16"

**SCHEMATIC  
SYMBOL**

The Model 141-1 Check Valve is shown on OCV Valve Schematics as:

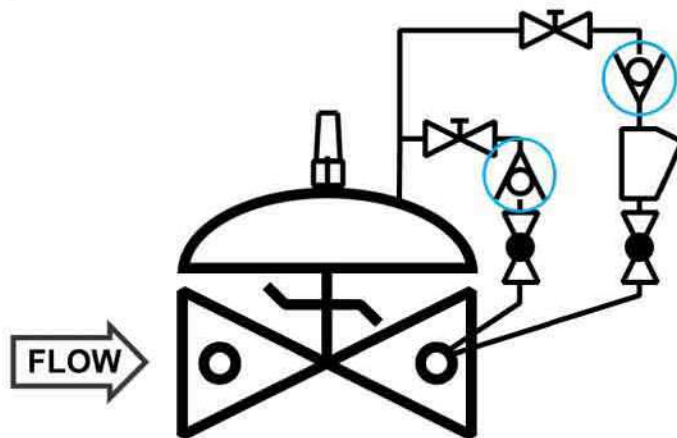
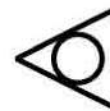

EXAMPLE: Shown here on a  
MODEL 94-3 Check Valve.

**Check Valve 141-1**





**DESCRIPTION**

**MODEL 159 Y-STRAINER**

The 159 Y-Strainer installs in the inlet piping of the pilot system and protects the pilot system from solid contaminants in the line fluid. It is the standard strainer for water service valves.

**MODEL 159 Y-STRAINER MATRIX**

MATERIAL	PART NUMBER	INLET/OUTLET (NPT)	BLOW OFF PORT (NP)	A	STD. MESH	USED ON VALVE SIZE
Bronze	660100	3/8	3/8	2 11/16	24	1 1/4"-6"
Bronze	660101	1/2	3/8	2 5/8	24	8"-10"
Bronze	660102	3/4	3/8	3 5/16	24	12"-16"
Stn. Steel	660700	3/8	1/4	2 1/2	20	1 1/4"-6"
Stn. Steel	660701	1/2	1/4	2 1/2	20	8"-10"
Stn. Steel	660702	3/4	1/4	3 1/8	20	12"-16"

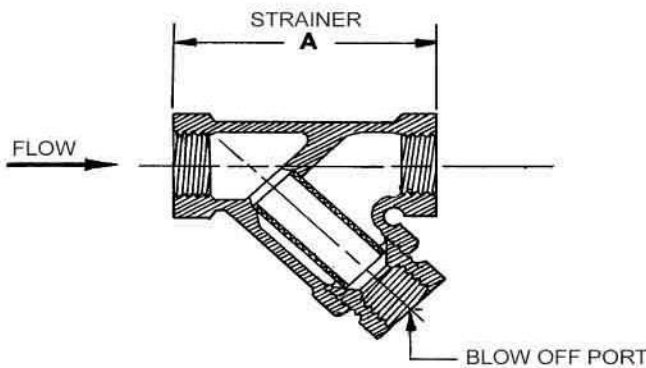

**MATERIALS**

Bronze, ASTM B62  
Optional mesh sizes: 50, 100

Stainless Steel, CF8-M (316)  
Optional mesh sizes: 60, 80, 100

Screens are stainless steel

**SCHEMATIC SYMBOL**

The Model 159 Y-Strainer is shown on OCV Valve Schematics as:

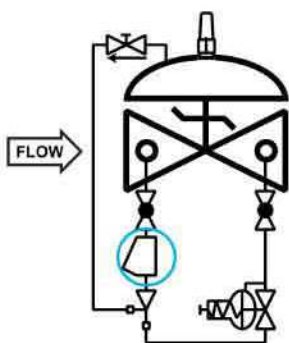

EXAMPLE: Shown here on a MODEL 127-3 Pressure Reducing Valve

**MAINTENANCE**

Routine cleaning and checking of the Y-Strainer will aid in keeping the control valve functioning properly. Pilot system isolation ball valves are supplied on valves equipped with the Model 159 Y-Strainer. These allow flushing of the screen through the blow off port, or removal of the screen itself for manual cleaning.

**DESCRIPTION**



The Model 141-4 Ball Valve is a 1/4-turn shutoff device used for isolating the pilot system from the main valve. They are extremely useful for performing routine maintenance and troubleshooting.

Ball valves are standard on water service valves; optional on fuel service valves.

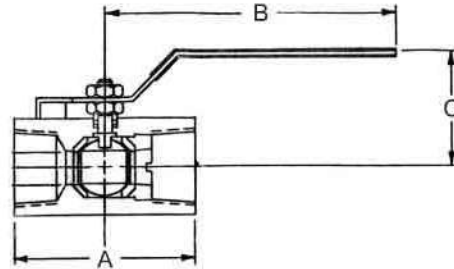

**MODEL 141-4 MATRIX**

MATERIAL	PART NUMBER	INLET/OUTLET (NPT)	A	B	C	USED ON VALVE SIZE*
Bronze	680100	3/8	1 3/4	3 1/2	1 7/8	1 1/4"-6"
Bronze	680101	1/2	2	3 1/2	2 1/4	8"-10"
Bronze	680102	3/4	3	4 3/4	2 1/4	12"-16"
Stn. Steel	680700	3/8	2	3 3/4	2 1/8	1 1/4"-6"
Stn. Steel	680701	1/2	2 1/4	3 3/4	2 1/2	8"-10"
Stn. Steel	680702	3/4	3	4 3/4	2 1/4	12"-16"

**SCHEMATIC SYMBOL**

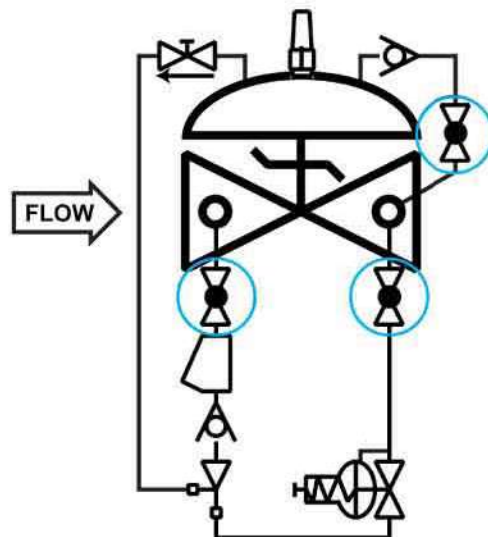

The Model 141-4 Ball Valve is shown on OCV Valve Schematics as:

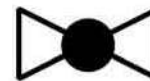

EXAMPLE: Shown here on a MODEL 127-4 Pressure Reducing / Check Valve.





**DESCRIPTION**

**MODEL 31 LIMIT SWITCH ASSEMBLY**

- Provides electrical indication of valve position.
- Adjustable to any point of valve travel.
- Heavy-duty stem seal.
- Installed without disassembly of valve.
- Available in weatherproof or explosion-proof enclosures.
- SPDT contacts (standard) DPDT (optional)

The Model 31 Limit Switch Assembly is a device that uses movement of the valve stem to make or break electrical contacts at designated points in the valve travel. It consists of an adaptor threaded into the center port of the valve bonnet, a rod threaded into the main valve stem, a heavy-duty stem seal, an actuating collar, and the switch unit. It may be installed on virtually any OCV control valve, and can be done so without any disassembly of the valve itself.

**WHERE USED** - Standard on Series 125/126 Pump Control Valves.  
Optional on all other series control valves.

**MODEL 31 ASSY MATRIX**

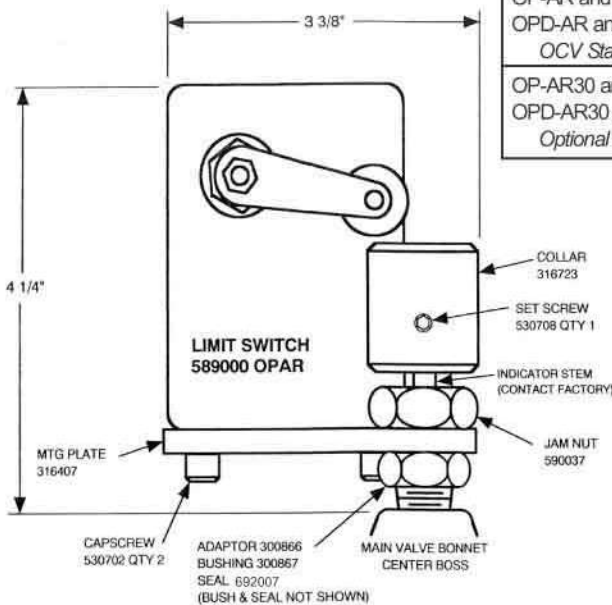

SWITCH TYPE	VALVE CLOSED	VALVE OPEN
OP-AR and EX-AR (SPDT)	N.C. contact(s) closed	N.C. contact(s) open
OPD-AR and EXD-AR-3 (DPDT)	N.O. contact(s) open	N.O. contact(s) closed
<i>OCV Standard Configuration</i>	Switch roller OFF collar	Switch roller ON collar
OP-AR30 and EX-AR30 (SPDT)	N.C. contact(s) open	N.C. contact(s) closed
OPD-AR30 and EXD-AR30-3 (DPDT)	N.O. contact(s) closed	N.O. contact(s) open
<i>Optional configuration</i>	Switch roller ON collar	Switch roller OFF collar

VALVE SIZE	PART NUMBER OP-AR (SPDT) Weatherproof	PART NUMBER EX-AR (SPDT) Explosion proof
1 1/4" - 1 1/2"	Consult factory	Consult factory
2" - 4"	252710	252413
6" - 8"	252720	252423
10 - 12"	252730	Consult factory
14" - 16"	252740	Consult factory

These part numbers include Buna-N stem seal. Consult Factory for part numbers on DPDT, other stem seals, and all model 31 switches shown in the Actuation matrix.

NOTE: Factory recommended valve installation should allow for indicator rod to be in the vertical position.

**SCHEMATIC SYMBOL**

The Model 31 is shown on OCV Valve Schematic as:

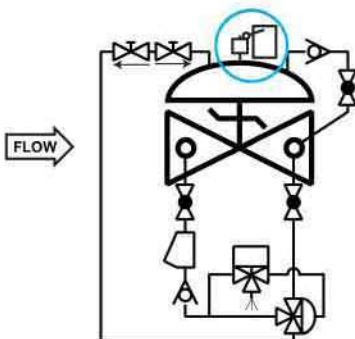

EXAMPLE:  
Shown here on a Model 125 Pump Control Valve

**ELECTRICAL RATING**

SPDT: 15 amps @ 125-480 VAC  
1/2 amp @ 125 VDC, 1/4 amp @ 250 VDC  
DPDT: 10 amps @ 125-250 VAC  
0.3 amp @ 125 VDC, 0.15 amp @ 250 VDC

**ENCLOSURES**

OP Switches Weatherproof NEMA 4  
EX Switches Explosion Proof NEMA 7, 9

**MATERIALS**

Indicator Rod: Stainless Steel  
Adapter: Stainless Steel  
Collars: Stainless Steel

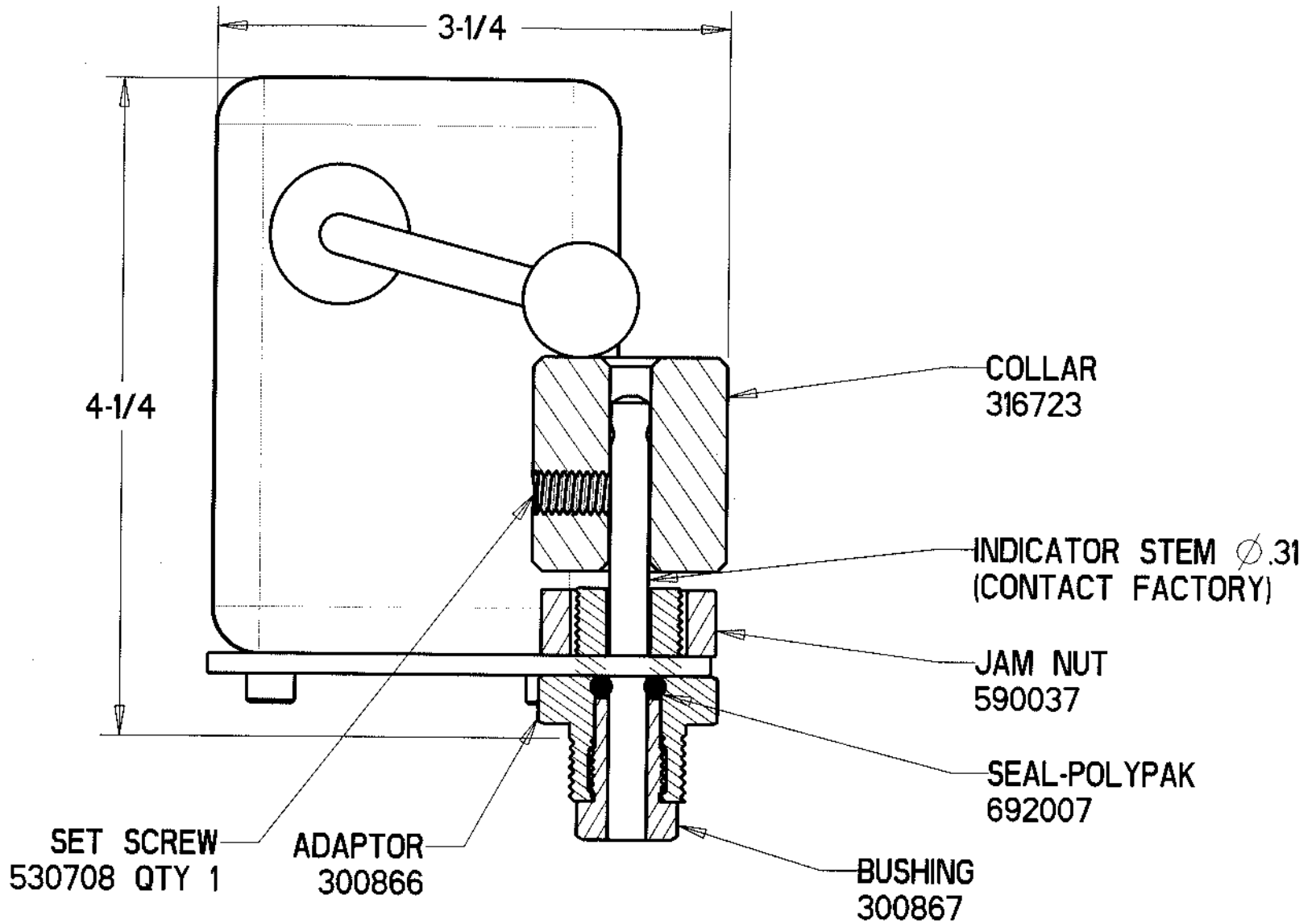

E					MATERIAL	TOLERANCES	<b>OCV Control Valves</b> TULSA OKLAHOMA USA					
D						UNLESS NOTED .XX $\pm .015$ .XXX $\pm .005$ ANGULAR $\pm 0.5^\circ$ MACH. FINISH 125				<b>LIMIT SWITCH ASSEMBLY</b>		
C							NO. REQD	DRAWN BY	DATE			
B								B.K.	2-13-08			
A							SCALE	CHKD BY	DATE	<b>A</b>	<b>MODEL 31</b>	
CHG	ECN	DATE	BY									
REVISIONS				REF DWG NO'S	FULL							