



◀ **66-shown**

The Model 66 provides an excellent solution for applications where there is inadequate differential pressure to actuate properly, the fluid being handled is extremely dirty or otherwise unsuitable, or it is preferable to use an outside fluid pressure source.

Typical examples include:

- Tank Safety (petroleum applications)
- Pump Control
- Low line pressure on/off
- Solenoid Valves

## SERIES FEATURES

- ▶ Operates automatically off line pressure or independent pressure source
- ▶ Dual diaphragm chamber isolated from flow path
- ▶ Rectangular-shaped, soft seat seal provides drip-tight Class VI closure
- ▶ Diaphragm assembly guided center and bottom
- ▶ Throttling seat
- ▶ Easily maintained without removal from the line
- ▶ Replaceable seat ring
- ▶ Center-tapped bonnet facilitates installation of position indicator or valve-actuated switches
- ▶ Valves are factory tested
- ▶ Serial numbered and registered to facilitate replacement parts and factory support

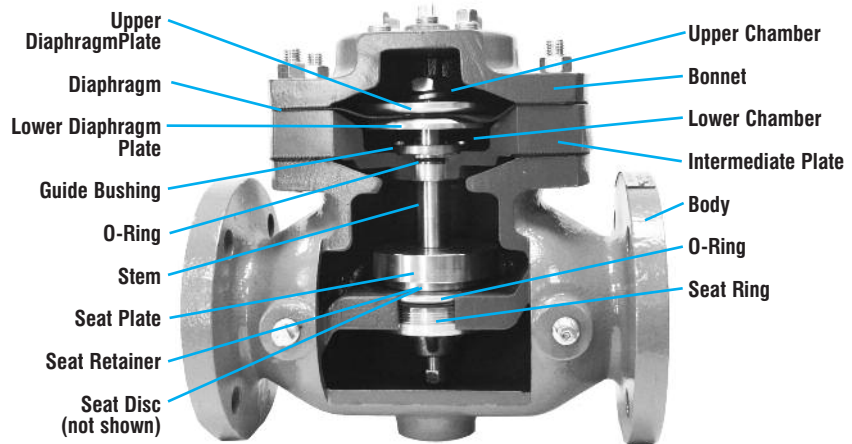

## OPERATION

The Model 66 is equipped with two diaphragm chambers, sealed from the valve's main flow passage by an intermediate plate. By pressurizing one control chamber while simultaneously venting the other, the valve is positively powered to both open and close.

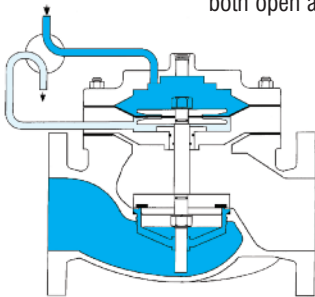

### Valve Closed

Applying pressure to the upper diaphragm chamber and simultaneously venting the lower chamber (typically to drain) causes the valve to go fully closed.

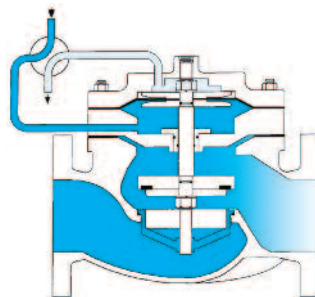

### Valve Open

Applying pressure to the lower diaphragm chamber and simultaneously venting the upper chamber (typically to drain) causes the valve to go fully open.

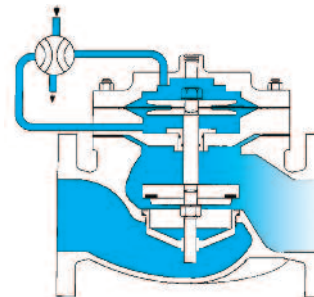

### Valve Modulating

Locking pressures in both the upper and lower diaphragm chamber simultaneously allows for holding the valve in a position other than full open or closed.

## FLOW CHARACTERISTICS

VALVE SIZE	US	1 1/4"	1 1/2"	2"	2 1/2"	3"	4"	6"	8"	10"	12"	14"	16"	24"
GLOBE Cv	US	23	27	47	68	120	200	450	760	1250	1940	2200	2850	6900
ANGLE Cv	US	30	35	65	87	160	270	550	1000	1600	2400	—	4000	—

where:  
 $Q$  = Flow Rate in USGPM (US)  
 $DP$  = Pressure drop in psi (US)  
 $Cv$  = Flow Rate in USCPM @ 1 psi pressure drop (US)  
 $sg$  = specific gravity of line fluid

## MAX. PRESSURE

(The pressures listed below are maximum pressures at 100°F.)

END CONNECTIONS	DUCTILE IRON	STEEL/STN STL
Threaded	640 psi	640 psi
Grooved	300 psi	300 psi
150# Flanged	250 psi	285 psi
300# Flanged	640 psi	740 psi

TOLL FREE 1.888.628.8258 • phone: (918)627.1942 • fax: (918)622.8916 • 7400 East 42nd Place, Tulsa, Ok 74145  
 email: sales@controlvalves.com • website: www.controlvalves.com

## SIZES

Screwed Ends - 1 1/4"-3"  
 Grooved Ends - 1 1/2"-6"  
 (globe); 1-1/2"-4" (angle)  
 Flanged Ends - 1 1/4" - 24"  
 (globe); 1 1/4"-16" (angle)

## FLUID OPERATING

### TEMPERATURE RANGE

EPDM: 32°F - 230°F\*

## MATERIALS

Consult factory for others.  
**Body/Bonnet:** Ductile Iron (epoxy coated), Carbon Steel (epoxy coated), Stainless Steel, low-lead Bronze  
 -Others available (consult factory)  
**Seat Ring:** low-lead Bronze, Stainless Steel  
**Stem:** Stainless Steel, Monel  
**Spring:** Stainless Steel  
**Diaphragm:** EPDM\*  
**Seat Disc:** EPDM\*

\*Others available upon request.

\*\*Valves 1-1/4" through 24" are certified to NSF/ANSI 372. Valves 4" through 24" are also certified to NSF/ANSI 61-G.

# SPECIFICATIONS (Typical Water Application)

The power actuated, dual chamber valve shall function to open fully by pressuring the lower diaphragm chamber and venting the upper chamber. It shall close drip tight by pressuring the upper chamber and venting the lower chamber.

## DESIGN

The power actuated valve shall be a dual chamber, single-seated, line or remote pressure operated, diaphragm actuated, globe or angle valve. The valve shall consist of a body, bonnet and intermediate plate. A diaphragm shall form two operating chambers, separated from line fluid by the intermediate plate. The valve shall seal closed by means of a corrosion-resistant seat and a resilient, rectangular seat disc. These, and other parts, shall be replaceable without removing the valve from the line. Alignment of the body and bonnet shall be by precision dowel pins. The diaphragm shall not be used as a seating surface, nor shall the pistons be used as an operating means. The power actuated valve shall be operationally and hydrostatically tested prior to shipment.

## MATERIALS OF CONSTRUCTION

The main valve body, bonnet and intermediate plate shall be ductile iron per ASTM A536, Grade 65-45-12. All ferrous surfaces shall be coated with 4 mils of epoxy. The main valve seat ring shall be low-lead Bronze. Elastomers (diaphragms, resilient seats and O-rings) shall be EPDM.

## OPERATING CONDITIONS

The power actuated valve shall open and close by venting and pressurizing the diaphragm chambers <X to X> psi. It shall be suitable for a flow rate of <X to X> gpm.

## ACCEPTABLE PRODUCTS

The power actuated valve shall be a <size> Model 66, <globe pattern, angle pattern>, with <150# flanged, 300# flanged, threaded, grooved> end connections, as manufactured by OCV Control Valves, Tulsa, Oklahoma, USA.

U.S. DIMENSIONS - INCHES

DIM	END CONN.	1 1/4-1 1/2	2	2 1/2	3	4	6	8	10	12	14	16	24
A	SCREWED	8 3/4	9 7/8	10 1/2	13	--	--	--	--	--	--	--	--
	GROOVED	8 3/4	9 7/8	10 1/2	13	15 1/4	--	--	--	--	--	--	--
	150# FLGD	8 1/2	9 3/8	10 1/2	12	15	17 3/4	25 3/8	29 3/4	34	39	40 3/8	62
	300# FLGD	8 3/4	9 7/8	11 1/8	12 3/4	15 5/8	18 5/8	26 3/8	31 1/8	35 1/2	40 1/2	42	63 3/4
B	SCREWED	1 7/16	1 11/16	1 7/8	2 1/4	--	--	--	--	--	--	--	--
	GROOVED	1*	1 3/16	1 7/16	1 3/4	2 1/4	--	--	--	--	--	--	--
	150# FLGD	2 5/16-2 1/2	3	3 1/2	3 3/4	4 1/2	5 1/2	6 3/4	8	9 1/2	10 5/8	11 3/4	16
	300# FLGD	2 5/8-3 1/16	3 1/4	3 3/4	4 1/8	5	6 1/4	7 1/2	8 3/4	10 1/4	11 1/2	12 3/4	18
C ANGLE	SCREWED	4 3/8	4 3/4	6	6 1/2	--	--	--	--	--	--	--	--
	GROOVED	4 3/8*	4 3/4	6	6 1/2	7 5/8	--	--	--	--	--	--	--
	150# FLGD	4 1/4	4 3/4	6	6	7 1/2	10	12 11/16	14 7/8	17	--	20 13/16	--
	300# FLGD	4 3/8	5	6 3/8	6 3/8	7 13/16	10 1/2	13 3/16	15 9/16	17 3/4	--	21 5/8	--
D ANGLE	SCREWED	3 1/8	3 7/8	4	4 1/2	--	--	--	--	--	--	--	--
	GROOVED	3 1/8*	3 7/8	4	4 1/2	5 5/8	--	--	--	--	--	--	--
	150# FLGD	3	3 7/8	4	4	5 1/2	6	8	11 3/8	11	--	15 11/16	--
	300# FLGD	3 1/8	4 1/8	4 3/8	4 3/8	5 13/16	6 1/2	8 1/2	12 1/16	11 3/4	--	16 1/2	--
E	ALL	7	7	8 1/2	7 3/4	9 3/4	11 3/4	14 5/8	19 1/8	20 3/4	22 1/4	24 1/4	33
F	ALL	3 7/8	3 7/8	3 7/8	3 7/8	3 7/8	3 7/8	6 3/8	6 3/8	6 3/8	6 3/8	6 3/8	8
G	ALL	6	6 3/4	7 11/16	8 3/4	11 3/4	14	21	24 1/2	28	31 1/4	34 1/2	52
H	ALL	10	11	11	11	12	13	14	17	18	20	20	28 1/2

\*GROOVED END NOT AVAILABLE IN 1 1/4"

For maximum efficiency, the OCV control valve should be mounted in a piping system so that the valve bonnet (cover) is in the top position. Other positions are acceptable but may not allow the valve to function to its fullest and safest potential. In particular, please consult the factory before installing 8" and larger valves, or any valves with a limit switch, in positions other than described. Space should be taken into consideration when mounting valves and their pilot systems.

A routine inspection & maintenance program should be established and conducted yearly by a qualified technician. Consult our factory @ **1-888-628-8258** for parts and service.

### How to order your valve

Unless ordered separately, the Model 66 valve will be included in the valve model number ordered. Refer to the specific model number when ordering.

When ordering the basic 66 valve separately please provide:

Valve Size - Globe or Angle  
 Pressure Class - Screwed, Flanged Grooved -  
 Materials of Construction: Body, Elastomers, Trim Material  
 Special Needs / Or Installation Requirements.

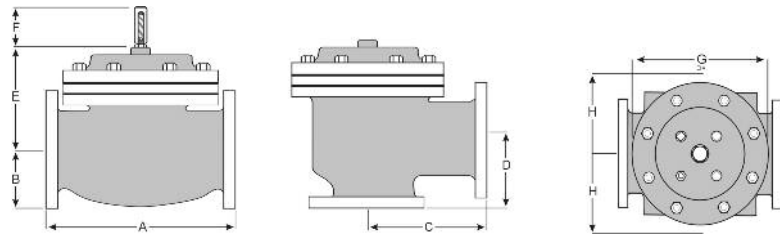

Represented by: