

- Bottom-mount flange (7.5" diameter)
- Integral water drain valve optional
- Pilot float "rides" the interface between water and fuel
- Four-way control to actuate discharge slug valve and/or automatic water drain valve
- Uses time-proven 800 pilot block (see Model Sheet 800)
- Stainless Steel pilot and float assembly
- Manual tester standard
- Factory tested

The Model 800B is a bottom-mounted filter separator float that allows only the discharge of clean, water-free fuel from the filter separator. The four models are as follows:

MODEL	PART NUMBER (without water drain)	FLANGE MATERIAL	PILOT/FLOAT ASSEMBLY
800B-4MT	230213	Bronze	Stainless Steel
800B-5MT	230773	Ductile Iron, Epoxy coated	Stainless Steel
800B-6MT	230783	Stainless Steel	Stainless Steel
800B-8MT	230872	Aluminum	Stainless Steel

PILOT BLOCK PORT CONNECTIONS (All ports 1/8" NPT)

POWER: Filter separator vessel pressure

ACCELERATOR VALVE: Bonnet of accelerator pilot on discharge slug valve

WATER DRAIN: Bonnet of automatic water drain valve

EXHAUST: Atmospheric drain line

OPERATION

The float of the 800B is counterweighted so that it will float in water, but sink in fuel. Depending on the water level in the filter separator, the 800B actuates the other control components in the system as follows:

FLOAT POSITION	DISCHARGE (SLUG) VALVE	WATER DRAIN VALVE (if equipped)
DOWN (No Water)	OPEN	CLOSED
MEDIAN (Rising Water)	OPEN	OPEN
UP (High Water)		

Actuating the manual tester will raise the float to the median or up positions, confirming the proper operation of the pilot, slug valve, and/or the water drain valve.

MAXIMUM PRESSURE:
 (at 100°F/37.78°C)
 300 psi (20.7 bar)

OPERATING TEMPERATURE:
 32°-120°F
 (0°-49°C)

MAXIMUM FUEL SPECIFIC GRAVITY:
 0.85

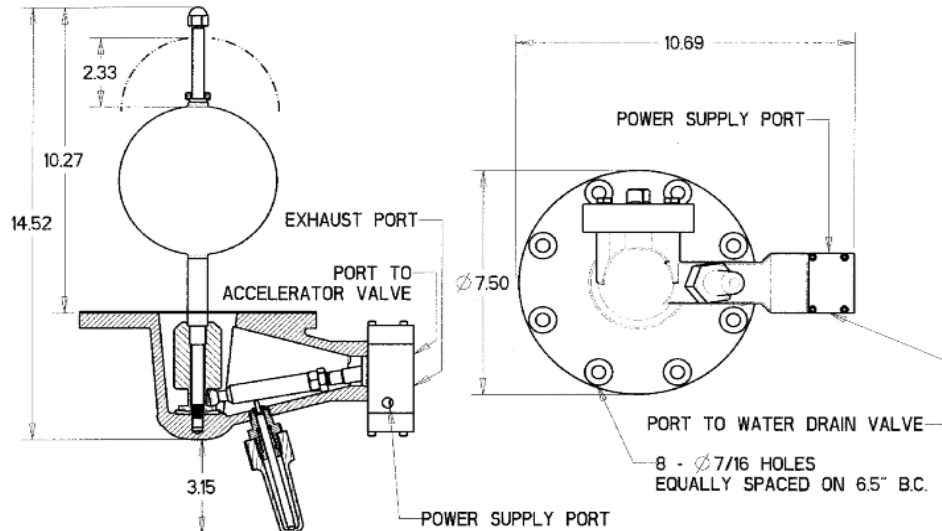

TOLL FREE 1.888.628.8258 ● phone: (918)627.1942 ● fax: (918)622.8916

7400 East 42nd Place, Tulsa, OK 74145 ● email: sales@controlvalves.com ● website: www.controlvalves.com