

▲ Model 8102

The Model 8102 is applicable anywhere it is necessary to automatically maintain an essentially constant level in storage tanks or reservoirs. Such applications occur in:

- Municipal water
- Rural water
- Water treatment facilities
- Storage tanks
- Fire protection systems

If the valve is to be primarily used for high level shut-off, consult factory.

## SERIES FEATURES

- ▶ Maintains tank level within narrow limits
- ▶ Can also be used for high level shut-off
- ▶ Float pilot can be provided valve-mounted or remote-mounted
- ▶ Float pilot design allows air gap to prevent cross connection
- ▶ Vertical rod and stops allow for adjustable level
- ▶ Single field-installed line between valve and float pilot
- ▶ Can be maintained without removal from the line
- ▶ Adjustable response speed
- ▶ Factory tested

## OPERATION

The Model 8102 is designed for tank fill only. A rotary, float-activated pilot controls the position of the main valve. With the float in the full down position, the pilot is wide open, as is the main valve. As the float begins to rise, the pilot begins to restrict flow, causing the main valve to throttle further closed. When fluid level raises the float to the full up position, flow is blocked and the main valve is closed.

By positioning the float on the vertical rods by means of the stop collars, the fluid level (distance between float ball and the pilot itself) can be selected.

## COMPONENTS

The Model 8102 consists of the following components, arranged as shown on the schematic diagram:

- 1.) Model 65 Basic Control Valve
- 2.) Model 813 Two-Way Float Pilot
- 3.) Model 126 Ejector  
Fixed orifice pilot system supply restrictor
- 4.) Model 141-2 Needle Valve  
Adjustable response speed
- 5.) Model 159 Y-Strainer  
Protects pilot system from dirt/debris
- 6.) Model 141-4 Isolation Ball Valves
- 7.) Model 155 Visual Indicator (Optional)

## SIZING

While most Model 8100 Float Valves are line size, there are two factors to check. To keep from using too small a valve, flow rate should be limited to a maximum of 25 ft/sec velocity. Too large a valve can result in loss of inlet pressure, which is needed to close the valve on high level. Definitive sizing information can be found in the OCV Catalog, Series 8100 section and Engineering section Performance Charts. Consult the factory for assistance and a copy of the OCV ValveMaster Sizing program.

SIZE	1 1/4"-1 1/2"	2"	2 1/2"	3"	4"	6"
MIN. FLOW GPM	14 - 23	50	75	115	200	450
MAX. FLOW GPM	115 - 160	260	370	570	1000	2250

For larger sizes, refer to Model 8105.

**TOLL FREE 1.888.628.8258** ● phone: (918)627.1942 ● fax: (918)622.8916 ● 7400 East 42nd Place, Tulsa, Ok 74145  
 email: sales@controlvalves.com ● website: www.controlvalves.com

## SCHEMATIC

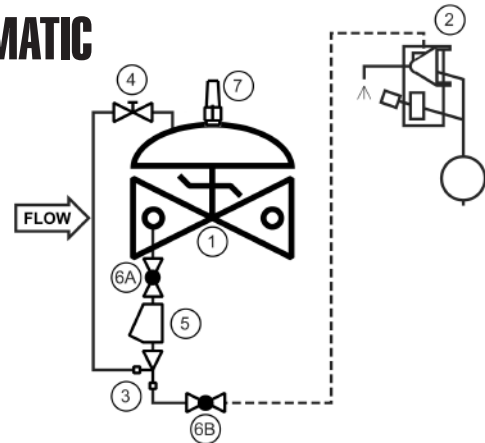

## RECOMMENDED INSTALLATION

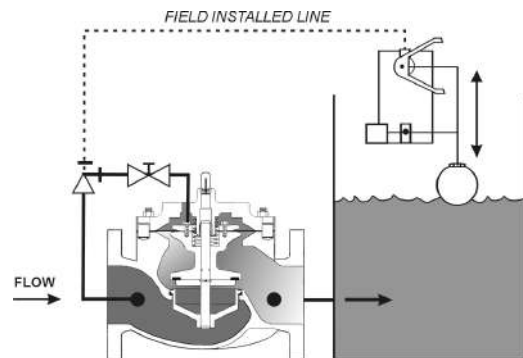

# Model 8102



## SIZES GLOBE/ANGLE

Screwed Ends - 1 1/4" - 3"  
 Grooved Ends - 1 1/2" - 4" (globe);  
 1 1/2" - 4" (angle)  
 Flanged Ends - 1 1/4" - 6" (globe);  
 1 1/4" - 6" (angle)

## MAX. PRESSURE

Limited by float pilot to 250 psi maximum, all materials and end connections (maximum pressures at 100°F).

## FLUID OPERATING TEMPERATURE RANGE

(Valve Elastomers)  
 EPDM 32°F - 230°F\*

## MATERIALS Consult factory for others.

**Body/Bonnet:** Ductile Iron (epoxy coated), Carbon Steel (epoxy coated), Stainless Steel, low-lead Bronze

-Others available (consult factory)

**Seat Ring:** low-lead Bronze, Stainless Steel

**Stem:** Stainless Steel, Monel

**Spring:** Stainless Steel

**Diaphragm:** EPDM\*

**Seat Disc:** EPDM\*

**Pilot:** low-lead Bronze, Stainless Steel

*Other pilot system components:*

low-lead Bronze/Brass, All Stainless Steel

**Tubing & Fittings:** Copper/Brass, Stainless Steel

**Float Pilot - Rods:**

Sizes 1 1/4"-6" supplied with (2) 12" rods

\*Others available upon request.

\*\*Valves 1-1/4" through 24" are certified to NSF/ANSI 372. Valves 4" through 24" are also certified to NSF/ANSI 61-G.

# SPECIFICATIONS (Typical Water Application)

The modulating float valve shall be installed on the inlet line to the tank and shall modulate to hold a constant level in the tank, thus balancing inflow and outflow levels. The modulating float valve shall include a simple, two-way, adjustable, air-gap type float pilot to be installed in the tank and be connected to the main valve by a single, customer-installed sense line.

## DESIGN

The modulating float valve shall be a single-seated, line pressure operated, diaphragm actuated, pilot controlled globe valve. The valve shall seal by means of a corrosion-resistant seat and a resilient, rectangular seat disc. These and other parts shall be replaceable without removing the valve from the line. The stem of the main valve shall be guided top and bottom by integral bushings. Alignment of the body, bonnet and diaphragm assembly shall be by precision dowel pins. The diaphragm shall not be used as a seating surface, nor shall the pistons be used as an operating means. The pilot system shall include a speed control, Y-strainer and isolation ball valves. The float pilot shall be furnished separately for remote mounting in the tank. The modulating float valve shall be operationally and hydrostatically tested prior to shipment.

## MATERIALS OF CONSTRUCTION

The main valve body and bonnet shall be ductile iron per ASTM A536, Grade 65-45-12. All ferrous surfaces shall be coated with 4 mils of epoxy. The main valve seat ring shall be low-lead Bronze. Elastomers (diaphragms, resilient seats and O-rings) shall be EPDM. The float pilot shall be low-lead Bronze, with stainless steel internals. The 5" spherical float shall be stainless steel, as shall the float rods and linkage. The isolation ball valves shall be brass, and control line tubing shall be copper.

## OPERATING CONDITIONS

The modulating float valve shall be suitable for a maximum flow rate of <X> gpm at inlet pressures ranging from <X> to X> psi.

## ACCEPTABLE PRODUCTS

The modulating float valve shall be a <size> Model 8102, <globe pattern, angle pattern>, with <150# flanged, 300# flanged, threaded, grooved> end connections, as manufactured by OCV Control Valves, Tulsa, Oklahoma, USA.

U.S. DIMENSIONS - INCHES

DIM	END CONN.	1 1/4-1 1/2	2	2 1/2	3	4	6	8	10	12	14	16	24
A	SCREWED	8 3/4	9 7/8	10 1/2	13	--	--	--	--	--	--	--	--
	GROOVED	8 3/4	9 7/8	10 1/2	13	15 1/4	20	--	--	--	--	--	--
	150# FLGD	8 1/2	9 3/8	10 1/2	12	15	17 3/4	25 3/8	29 3/4	34	39	40 3/8	62
	300# FLGD	8 3/4	9 7/8	11 1/8	12 3/4	15 5/8	18 5/8	26 3/8	31 1/8	35 1/2	40 1/2	42	63 3/4
C	SCREWED	4 3/8	4 3/4	6	6 1/2	--	--	--	--	--	--	--	--
	GROOVED	4 3/8*	4 3/4	6	6 1/2	7 5/8	--	--	--	--	--	--	--
	150# FLGD	4 1/4	4 3/4	6	6	7 1/2	10	12 11/16	14 7/8	17	--	20 13/16	--
	300# FLGD	4 3/8	5	6 3/8	6 3/8	7 13/16	10 1/2	13 3/16	15 9/16	17 3/4	--	21 5/8	--
D	SCREWED	3 1/8	3 7/8	4	4 1/2	--	--	--	--	--	--	--	--
	GROOVED	3 1/8*	3 7/8	4	4 1/2	5 5/8	--	--	--	--	--	--	--
	150# FLGD	3	3 7/8	4	4	5 1/2	6	8	11 3/8	11	--	15 11/16	--
E	ALL	6	6	7	6 1/2	8	10	11 7/8	15 3/8	17	18	19	27
	H	ALL	10	11	11	11	12	13	14	17	18	20	28 1/2

\*GROOVED END NOT AVAILABLE IN 1 1/4"

For maximum efficiency, the OCV control valve should be mounted in a piping system so that the valve bonnet (cover) is in the top position. Other positions are acceptable but may not allow the valve to function to its fullest and safest potential. In particular, please consult the factory before installing 8" and larger valves, or any valves with a limit switch, in positions other than described. Space should be taken into consideration when mounting valves and their pilot systems.

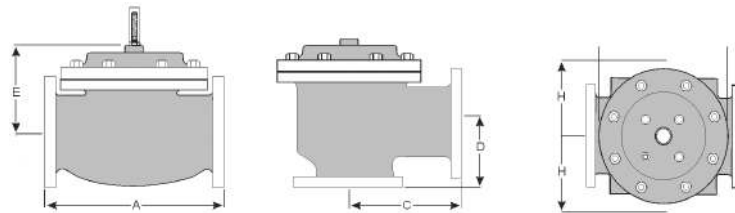

A routine inspection & maintenance program should be established and conducted yearly by a qualified technician. Consult our factory @ 1-888-628-8258 for parts and service.

## How to order your Model 8102 valve

When Ordering please provide:  
 Fluid to be controlled -Model Number -Size  
 Globe or Angle -End Connection -Body Material  
 Trim Material -Pilot Options -Pilot Mounting: on valve or remote -Special Requirements / Installation Requirements

Represented by:

TOLL FREE 1.888.628.8258 • phone: (918)627.1942 • fax: (918)622.8916 • 7400 East 42nd Place, Tulsa, Oklahoma 74145  
 email: sales@controlvalves.com • website: www.controlvalves.com