

installation, operating and maintenance instructions

high level shutoff valve

model 8106

GENERAL DESCRIPTION

The OCV Model 8106, with its chamber-mounted float pilot, is specifically designed for high level shutoff use on floating-pan tanks.

The 8106 consists of the following components, arranged as shown on the schematic diagram:

1. **Model 65 Basic Valve Assembly**, a hydraulically operated, diaphragm actuated, pilot controlled globe valve which closes with an elastomer-on-metal seal.
2. **Model 815 Float Pilot**, a two way float actuated pilot valve which closes as the float rises. It is furnished with a float chamber designed for mounting on the side of the receiving tank.
3. **Model 1356 Differential Control Pilot**, a two way, normally closed pilot valve which acts as a relay between the float pilot and the main valve.
4. **Model 126 Ejector**, a simple tee fitting with a small orifice in its inlet port. Acting in conjunction with the differential control pilot, the ejector provides the proper pressures to the main valve diaphragm chamber for opening and closing the valve.
5. Two **Model 141-2 Needle Valves**. Needle valve (5A) controls the opening and closing speeds of the main valve. Needle valve (5B), working in conjunction with the float pilot, controls the actuating pressure for the differential control pilot.

6. **Model 123 Inline Strainer**, which protects the pilot system from solid contaminants in the line fluid.
7. **Model 141-4 Ball Valve**, which provides a means of manually testing the 8106's shutoff capability.
8. **Model 155L Visual Indicator**, which enables the user to determine the valve's operating position at a glance.

THEORY OF OPERATION

Operation of the 8106 can be readily seen by referring to the schematic diagram. At the heart of the system is the differential control pilot (3). This is a normally-closed pilot, with its degree of opening determined by the balance of forces acting across its diaphragm. Full inlet pressure is applied under the diaphragm, while force on top of the diaphragm is a combination of inlet pressure applied through needle valve (5B), plus spring loading, minus the pressure relieved through the float pilot (2).

When the float is down, the float pilot (2) relieves more pressure from the upper chamber of the differential pilot than can be provided by needle valve (5B). Inlet pressure acting under the diaphragm forces the pilot open. Flow through the ejector (4) and differential pilot reduces the pressure on the diaphragm of the main valve (1), causing the valve to open.

When the float reaches its full up position, no pressure can be relieved from the upper chamber of the differ-

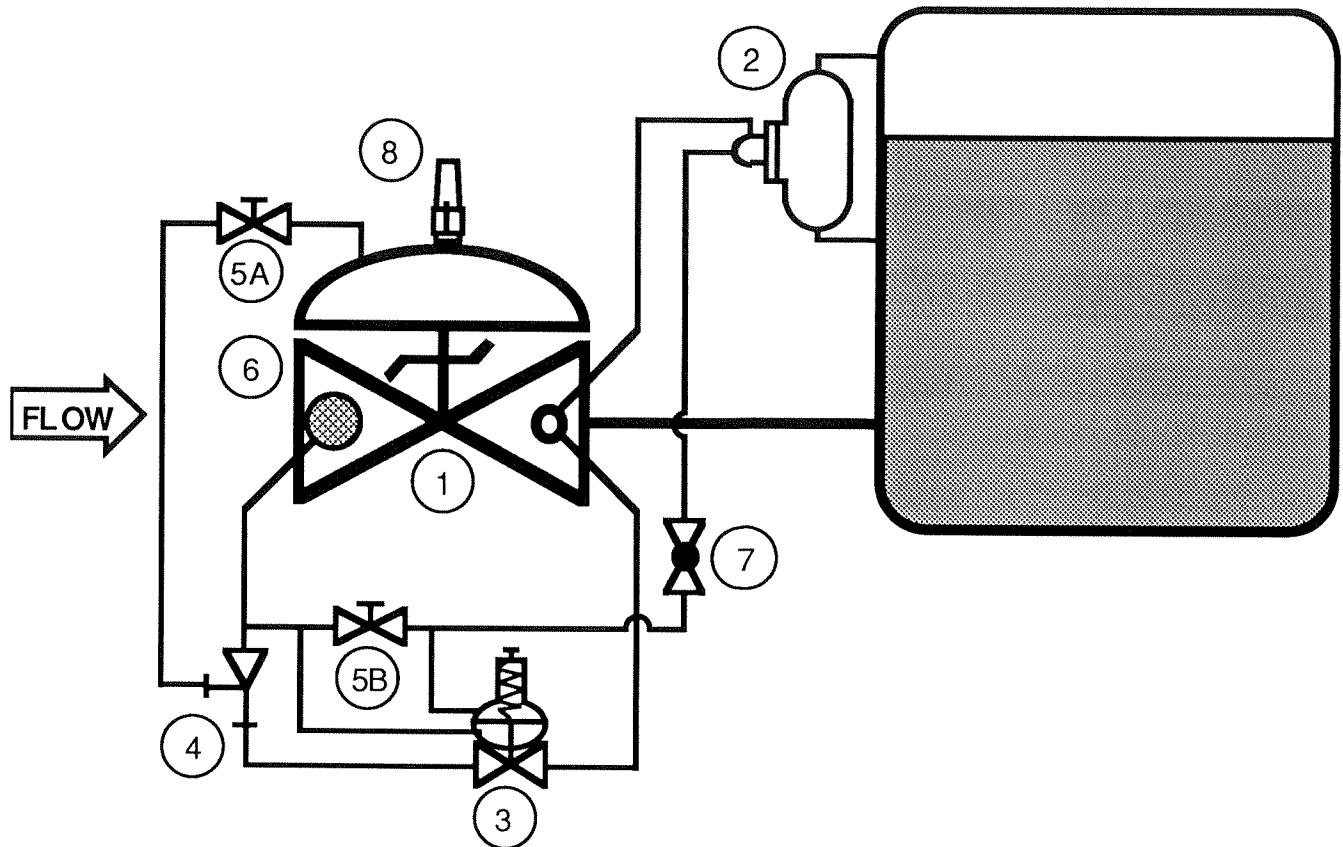

ential pilot, which results in a pressure balance across the diaphragm. Spring loading then forces the pilot fully closed. With no flow through the pilot, the ejector applies full inlet pressure to the main valve diaphragm chamber, moving the valve fully and tightly closed.

INSTALLATION

The 8106 valve is furnished fully factory assembled with the 815 float pilot furnished separately for remote installation. Refer to the Model 65 Basic Valve section of this manual for details of valve installation.

The 815 float pilot is mounted on the exterior tank wall by means of 1" pipe connected above and below the float chamber and to half couplings welded to the tank wall. Of course, holes must be cut into the tank to allow flow from the tank to the float chamber and vice-versa. Proper vertical location of the float chamber is important: the horizontal centerline of the chamber should be located 2" below the desired high level.

Two lines must be connected from the main valve to the float pilot. Refer to the drawing #8860 for float pilot port identification:

1. From the ball valve (7) to Port "A" of the float pilot.
2. From Port "B" of the float pilot to the unused downstream (tank side) body side port of the main valve.

Minimum recommended size for these lines is:

1. 1/4" pipe or 3/8" OD tubing for runs up to 20 feet.
2. 3/8" pipe or 1/2" OD tubing for runs over 20 feet.

STARTUP AND ADJUSTMENT

The procedures listed below should be followed in order to effect an initial startup of the 8106. NOTE: In order to perform the startup, the receiving tank must be at least a foot or two below high level.

1. Loosen the jam nut on needle valve (5B) and turn the adjusting screw **clockwise** to a full stop. Then turn it **counter-clockwise** two full turns.
2. Close ball valve (7).
3. Start the pump or otherwise pressurize the valve. The valve will remain closed or else open only a very small amount.

4. Carefully loosen a pipe plug in the main valve bonnet until fluid appears around the threads. When only clear fluid (no air) is discharging, retighten the plug.
5. Open ball valve (7). The valve should now open.
 - (a) If the valve opens, proceed to Step 7.
 - (b) If the valve does not open, or the opening is marginal, proceed to Step 6.
6. Remove the protective cap from the differential control pilot (3) and loosen the adjusting screw jam nut. Working back and forth between the differential pilot and needle valve (6B), perform the following until the valve opens.
 - (a) Turn the adjusting screw of differential pilot (3) **counter-clockwise** 1/4 turn at a time.
 - (b) Turn the adjusting screw of needle valve (5B) **clockwise** 1/4 turn at a time. **CAUTION:** *Never close needle valve (5B) completely. To do so will keep the valve from closing.*
7. Close ball valve (7). The valve should close.
 - (a) If the valve closes, proceed to Step 9.
 - (b) If the valve does not close, proceed to Step 8.
8. Remove the protective cap from the differential control pilot (3) and loosen the adjusting screw jam nut. Working back and forth between the differential pilot and needle valve (5B), perform the following until the valve opens.
 - (a) Turn the adjusting screw of differential pilot (3) **clockwise** 1/4 turn at a time.
 - (b) Turn the adjusting screw of needle valve (5B) **counter-clockwise** 1/4 turn at a time.
9. Reopen ball valve (7). The valve should reopen.
10. Opening and closing speed of the valve is set by needle valve (5A). Turn the adjusting screw **clockwise** to decrease opening/closing speed; **counter-clockwise** to increase opening/closing speed. **CAUTION:** *Never close needle valve (5A) completely. To do so will keep the valve from operating.*
11. The above procedure, using manual ball valve (7), gives virtual certainty that the valve will close

when high level is reached. However, it is always a good idea to closely monitor the valve as high level is approached on initial tank fill.

MAINTENANCE

Required maintenance of the 8106 is minimal. Flanges and fittings should be checked periodically for leakage and tightened if necessary. Damage to the tubing, particularly the tubing connecting the main valve to the float pilot, should be corrected immediately.

TROUBLESHOOTING

In the event of malfunction of the 8106, the following guide should enable the technician to isolate the cause of the problem and take appropriate corrective action.

MAIN VALVE FAILS TO OPEN

1. Make sure the level in the tank is at least 6" below high level.
2. Main line isolation valve closed — Open as required.
3. Ball valve (7) closed — Open as required.
4. Needle valve (5A) closed fully — Open as required. See Adjustment Instructions.
5. Needle valve (5B) open too far — See Adjustment Instructions
6. Differential control pilot (3) adjusted too far clockwise — See Adjustment Instructions.
7. Differential pilot (3) diaphragm ruptured or stem binding — Disassemble pilot and determine cause. See the 1356 Pilot section of this manual.
8. Float pilot (2) clogged — Clean as required. See the 815 Pilot section of this manual.
9. Main valve (1) diaphragm ruptured or stem binding — Disassemble valve and determine cause. See the Model 65 Basic Valve section of this manual.

MAIN VALVE FAILS TO CLOSE

1. Make sure that high level has been reached.
2. Temporarily close ball valve (7).
 - (a) If the valve closes, proceed to Step 3.
 - (b) If the valve still does not close, proceed to Step 4.

3. Malfunction in float pilot (2): disc leaking badly or pilot is stuck in position — Make appropriate repairs. See the 815 Pilot section of this manual.
4. Needle valve (5A) closed fully — Open as required.
5. Needle valve (5B) closed too far — See Adjustment Instructions.
6. Differential control pilot (3) adjusted too far counter-clockwise — See Adjustment Instructions.
7. Differential control pilot (3) stem binding or seat deteriorated — Disassemble pilot and determine cause. See the 1356 Pilot section of this manual.
8. Main valve (1) stem binding or seat deteriorated — Disassemble valve and determine cause. See the Model 65 Basic Valve section of this manual.



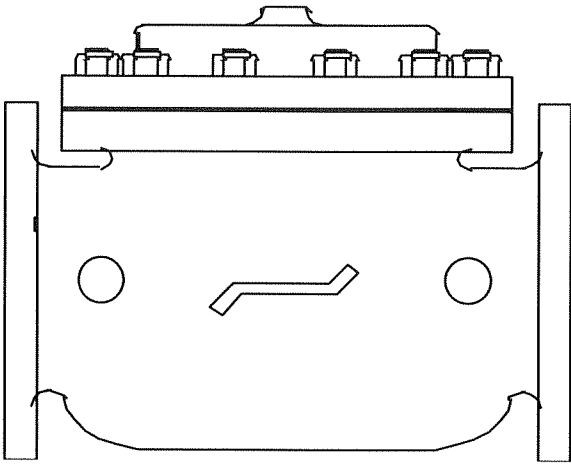

installation, operating, and maintenance instructions

series 65 basic control valve

GENERAL DESCRIPTION

The OCV Series 65 is a hydraulically-operated, diaphragm-actuated valve. It is available in either a globe (Model 65) or angle (Model 65A) configuration. The diaphragm is nylon-fabric bonded with synthetic rubber and forms a sealed chamber in the upper portion of the valve, separating operating pressure from line pressure. An elastomeric seat disc forms a tight seal with the valve seat when pressure is applied above the diaphragm.

FUNCTIONAL DESCRIPTION

Because the Series 65 is a hydraulically operated valve, it requires a minimum line pressure of approximately 5 psig in order to function. The valve functions on a simple principle of pressure differential. The line pressure at the inlet of the valve is bypassed through the pilot control piping to the diaphragm chamber of the valve. This pressure, together with the valve spring, works against the pressure under the valve seat. Because the effective area of the diaphragm is greater than that of the seat, the valve is held tightly closed. As the controlling pilot(s) allow the pressure to bleed off the diaphragm chamber, the two opposing pressures begin to balance and the valve will begin to open. The valve can be used to perform a simple on-off function, or with the proper pilot system, a modulating, or regulating function.

In cases where the line fluid is unusually dirty, or is otherwise unsuitable for operating the valve, an independent operating pressure source may be employed. The pressure available from such a source must be equal to, or greater than, line pressure.

INSTALLATION

In order to insure safe, accurate and efficient operation of the OCV control valve, the following list of checkpoints and procedures should be followed when installing the

valve.

1. Make a careful visual inspection of the valve to insure that there has been no damage to the external piping, fittings or controls. Check that all fittings are tight.
2. Thoroughly flush all interconnecting piping of chips, scale and foreign matter prior to mounting the valve.
3. Install the valve in the line according to the flow arrow on the inlet flange. The arrow should point downstream.
4. Allow sufficient room around the valve for ease of adjustment and maintenance service.

In addition, it is highly recommended that:

1. Isolation valves (eg., gate or butterfly) be installed on the inlet and discharge sides of the valve to facilitate isolating the valve for maintenance.
2. Pressure gauges be installed at the inlet and outlet sides of the valve to provide monitoring of the valve during initial start-up and during operation. The body side ports, if unused by the pilot system, provide a convenient connection for the gauges.
3. All valves larger than 6" be installed horizontally, i.e., with the bonnet pointed up, for ease of adjustment and maintenance servicing.

MAINTENANCE

The OCV control valve requires no lubrication and a minimum of maintenance. However, a periodic inspection should be established to determine how the fluid being handled is affecting the efficiency of the valve. In a water system, for example, the fluid velocity as well as the substances occurring in natural waters, such as dissolved minerals and suspended particles, vary in every installation. The effect of these actions or substances must be determined by inspection. It is recommended that an annual inspection, which includes ex-

amination of the valve interior, be conducted. Particular attention should be paid to the elastomeric parts, i.e., the diaphragm and seat disc. Any obviously worn parts should be replaced.

REPAIR PROCEDURES

In the event of malfunction of the OCV control valve, troubleshooting should be conducted according to the procedures outlined for the specific model of valve. Then, if those steps indicate a problem with the main valve, this section will outline the procedures necessary to correct the problem.

Problems with the main valve can be classed in three basic categories:

1. VALVE FAILS TO OPEN
 - a. Diaphragm damaged* - See Procedure A
 - b. Stem binding - See Procedure B
2. VALVE FAILS TO CLOSE
 - a. Diaphragm damaged* - See Procedure A
 - b. Stem binding - See Procedure B
 - c. Object lodged in valve - See Procedure B
3. VALVE OPENS AND CLOSES BUT LEAKS WHEN CLOSED
 - a. Seat disc damaged - See Procedure C
 - b. Seat ring damaged - See Procedure D

*A diaphragm failure can prevent the valve from either opening or closing, depending on the flow direction. Most water service valves flow "under the seat", in which case a diaphragm failure will keep the valve from closing. On the other hand, most fuel service valves flow "over the seat", in which case a diaphragm failure will keep the valve from opening. To determine which you have, examine the bridge mark cast into the side of the valve body, then compare it with the figures below.

PROCEDURE A : DIAPHRAGM REPLACEMENT

1. Isolate the valve from the system by closing upstream and downstream block valves.
2. Loosen one of the tubing connections on the bonnet. Allow any residual pressure to bleed off.
3. Remove all tubing connected at the bonnet.
4. Remove the bonnet nuts.
5. Remove the bonnet. If the bonnet sticks in place, it may be loosened by rapping sharply around its edge with a rubber-headed mallet. *NOTE: 8" and larger valves are equipped with eye bolts through which a chain can be fastened to aid in*

lifting the bonnet.

6. Remove the spring.
7. Remove the diaphragm plate capscrews and the diaphragm plate.
8. Remove the old diaphragm.
9. Making sure the dowel pin holes are in the proper location, place the new diaphragm over the studs and press down until it is flat against the body and spool.
10. Replace the diaphragm plate and the diaphragm plate capscrews.
11. Tighten all diaphragm plate capscrews snugly.
12. Replace the spring.
13. Replace the bonnet and reinstall the bonnet nuts.
14. Tighten the bonnet nuts snugly using a criss-cross tightening pattern.
15. Reinstall the control tubing.
16. Reopen the upstream and downstream block valves.
17. Before placing the valve back in service, perform the air bleed procedure described in the first section of this manual.

PROCEDURE B: CORRECTION OF BINDING STEM

1. Perform Steps 1 thru 6 of Procedure A, above.
2. Remove the spool assembly from the valve. *NOTE:*

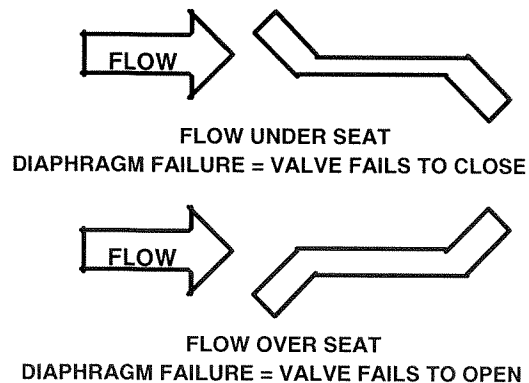

On smaller valves, this can be accomplished simply by grasping the stem and pulling upward. Valves 6" and larger have the top of the stem threaded to accept an eyebolt to aid in lifting the spool out of the body. 6" thru 12" valves are threaded 3/8-16. 14" and 16" valves are threaded 5/8-11.

3. Carefully examine both ends of the stem for deep scratches, scoring or buildup of mineral deposits.

- Polish the stem if necessary using a fine grade of emery cloth.
- 4. Similarly, examine and polish the upper bushing (in the bonnet) and the lower guide (in the seat ring).
- 5. Reinstall the spool assembly.
- 6. Reassemble the valve, following Steps 12 thru 17 in Procedure A.

PROCEDURE C: SEAT DISC REPLACEMENT

- 1. Perform Steps 1 and 2 of Procedure B, above.
- 2. With the spool assembly removed from the body, remove the seat retainer screws.
- 3. Slide the seat retainer off the lower end of the stem.
- 4. Remove the seat disc from its groove in the spool.
NOTE: The seat disc may fit quite tightly in the groove. If necessary, it may be pried out using a thin-bladed screwdriver or similar tool.
- 5. Install the new seat disc in the groove.
- 6. Reinstall the seat retainer and tighten the seat retainer screws.
- 7. Reassemble the valve, following Steps 5 and 6 of Procedure B.

PROCEDURE D: SEAT RING REPLACEMENT

NOTE: It is rare for a seat ring to require replacement. Minor nicks and scratches in the seating surface can usually be smoothed out with emery cloth.

- 1. Perform Steps 1 and 2 of Procedure B, above.
- 2. If you are working on a 4" or smaller valve, follow Steps 3 thru 9, below.
- 3. If you are working on a 6" or larger valve, follow Steps 10 thru 16, below.

- 4. Seat rings in valves 4" and smaller are threaded into the valve body. To remove, you will need a special seat ring tool. You may fabricate one using standard pipe as shown in the sketch below, or one may be purchased from OCV.
- 5. Using the seat ring tool, unthread the seat ring from the body.
- 6. Remove the old o-ring from the counterbore in the body.
- 7. Install the new o-ring in the counterbore.
- 8. Using the seat ring tool, install the new seat ring.
- 9. Reassemble the valve, following Steps 5 & 6 of Procedure B.
- 10. Seat rings in valves 6" and larger are bolted into the body with socket head capscrews. In addition you will note that the seat ring is equipped with additional threaded holes that may be used for "jacking" the seat ring out of the body.
- 11. Remove the socket head capscrews.
- 12. Remove the old seat ring from the body by temporarily installing two or more of the capscrews in the "jacking" holes.
- 13. Install a new o-ring in the groove of the new seat ring. Lubricate the o-ring and outer seat ring wall with Vaseline® or similar lubricant.
- 14. Install the new seat ring in the body, making sure that the capscrew holes line up.
- 15. Replace and tighten all the capscrews.
- 16. Reassemble the valve, following Steps 5 and 6 of Procedure B.

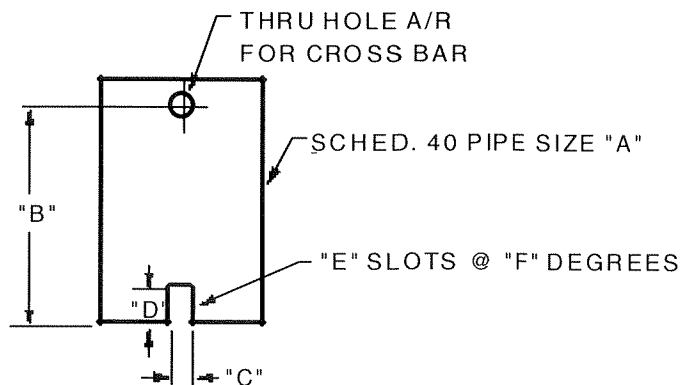

VALVE SIZE	"A" PIPE SIZE	"B" MIN. LENGTH	"C" SLOT WIDTH	"D" SLOT DEPTH	"E" NO. OF SLOTS	"F" SLOT SPACING
1-1/4"	3/4"	6"	3/8"	3/8"	2	180°
1-1/2"	3/4"	6"	3/8"	3/8"	2	180°
2"	1-1/2"	7"	3/8"	3/8"	2	180°
2-1/2"	2"	8"	1/2"	1/2"	3	120°
3"	2-1/2"	9"	5/8"	5/8"	2	180°
4"	3"	10"	5/8"	5/8"	2	180°

REVISED 3-17-97

Polish the stem if necessary using a fine grade of emery cloth.

4. Similarly, examine and polish the upper bushing (in the bonnet) and the lower guide (in the seat ring).
5. Reinstall the spool assembly.
6. Reassemble the valve, following Steps 12 thru 17 in Procedure A.

PROCEDURE C: SEAT DISC REPLACEMENT

1. Perform Steps 1 and 2 of Procedure B, above.
2. With the spool assembly removed from the body, remove the seat retainer screws.
3. Slide the seat retainer off the lower end of the stem.
4. Remove the seat disc from its groove in the spool.

NOTE: The seat disc may fit quite tightly in the groove. If necessary, it may be pried out using a thin-bladed screwdriver or similar tool.

5. Install the new seat disc in the groove.
6. Reinstall the seat retainer and tighten the seat retainer screws.
7. Reassemble the valve, following Steps 5 and 6 of Procedure B.

PROCEDURE D: SEAT RING REPLACEMENT

NOTE: It is rare for a seat ring to require replacement. Minor nicks and scratches in the seating surface can usually be smoothed out with emery cloth.

1. Perform Steps 1 and 2 of Procedure B, above.
2. If you are working on a 4" or smaller valve, follow Steps 3 thru 9, below.
3. If you are working on a 6" or larger valve, follow Steps 10 thru 16, below.

4. Seat rings in valves 4" and smaller are threaded into the valve body. To remove, you will need a special seat ring tool. You may fabricate one using standard pipe as shown in the sketch below, or one may be purchased from OCV.
5. Using the seat ring tool, unthread the seat ring from the body.
6. Remove the old o-ring from the counterbore in the body.
7. Install the new o-ring in the counterbore.
8. Using the seat ring tool, install the new seat ring.
9. Reassemble the valve, following Steps 5 & 6 of Procedure B.
10. Seat rings in valves 6" and larger are bolted into the body with socket head capscrews. In addition you will note that the seat ring is equipped with additional threaded holes that may be used for "jacking" the seat ring out of the body.
11. Remove the socket head capscrews.
12. Remove the old seat ring from the body by temporarily installing two or more of the capscrews in the "jacking" holes.
13. Install a new o-ring in the groove of the new seat ring. Lubricate the o-ring and outer seat ring wall with Vaseline® or similar lubricant.
14. Install the new seat ring in the body, making sure that the capscrew holes line up.
15. Replace and tighten all the capscrews.
16. Reassemble the valve, following Steps 5 and 6 of Procedure B.

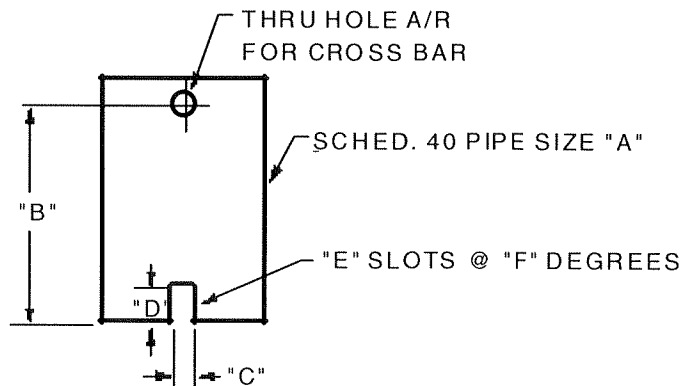

VALVE SIZE	"A" PIPE SIZE	"B" MIN. LENGTH	"C" SLOT WIDTH	"D" SLOT DEPTH	"E" NO. OF SLOTS	"F" SLOT SPACING
1-1/4"	3/4"	6"	3/8"	3/8"	2	180°
1-1/2"	3/4"	6"	3/8"	3/8"	2	180°
2"	1-1/2"	7"	3/8"	3/8"	2	180°
2-1/2"	2"	8"	1/2"	1/2"	3	120°
3"	2-1/2"	9"	5/8"	5/8"	2	180°
4"	3"	10"	5/8"	5/8"	2	180°

REVISED 3-17-97

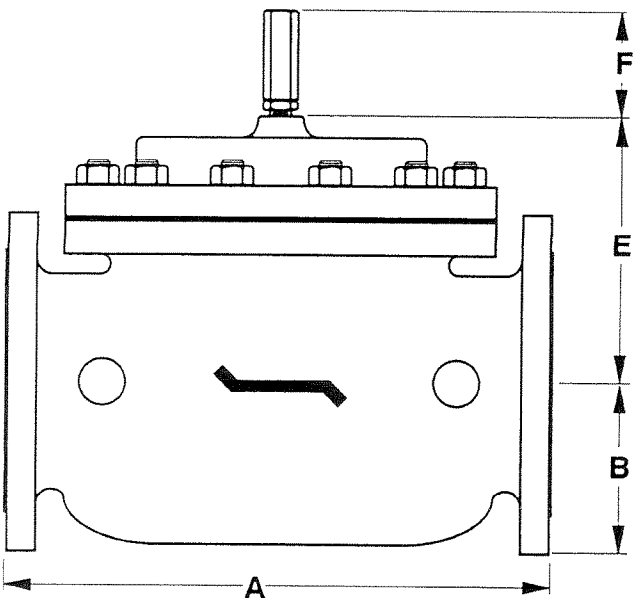
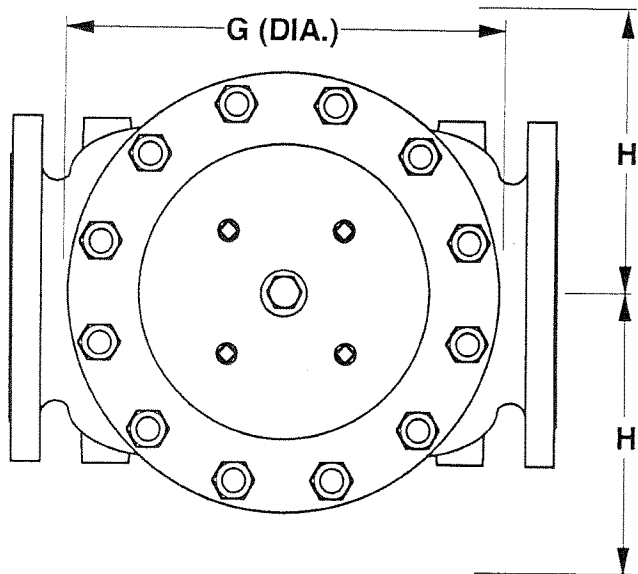

DIM	ANSI CLASS	VALVE SIZE												
		1 1/4	1 1/2	2	2 1/2	3	4	6	8	10	12	14	16	24
A	SE	8.75	8.75	9.88	10.50	13.00	-	-	-	-	-	-	-	-
	150	8.50	8.50	9.38	10.50	12.00	15.00	17.75	25.38	29.75	34.00	39.00	40.38	62.00
	300	8.75	8.75	9.88	11.12	12.75	15.62	18.62	26.38	31.12	35.50	40.50	42.00	63.75
B	SE	1.44	1.44	1.69	1.88	2.25	-	-	-	-	-	-	-	-
	150	2.31	2.50	3.00	3.50	3.75	4.50	5.50	6.75	8.00	9.50	10.62	11.75	16.00
	300	2.62	3.06	3.25	3.75	4.12	5.00	6.25	7.50	8.75	10.25	11.50	12.75	18.00
C	SE	4.38	4.38	4.75	6.00	6.50	-	-	-	-	-	-	-	-
	150	4.25	4.25	4.75	6.00	6.00	7.50	10.00	12.69	14.88	17.00	-	20.81	-
	300	4 3/8	4.38	5.00	6.38	6.38	7.81	10.50	13.19	15.56	17.75	-	21.62	-
D	SE	3.12	3.12	3.88	4.00	4.50	-	-	-	-	-	-	-	-
	150	3.00	3.00	3.88	4.00	4.00	5.50	6.00	8.00	11.38	11.00	-	15.69	-
	300	3.25	3.25	4.12	4.38	4.38	5.81	6.50	8.50	12.06	11.75	-	16.50	-
E	ALL	6.00	6.00	6.00	7.00	6.50	7.92	10.00	11.88	15.38	17.00	18.00	19.00	27.00
F	ALL	3.88	3.88	3.88	3.88	3.88	3.88	3.88	6.38	6.38	6.38	6.38	6.38	8.00
G	ALL	6.00	6.00	6.75	7.69	8.75	11.75	14.00	21.00	24.50	28.00	31.25	34.50	52.00
H	ALL	10.00	10.00	11.00	11.00	11.00	12.00	13.00	14.00	17.00	18.00	20.00	20.00	28.50

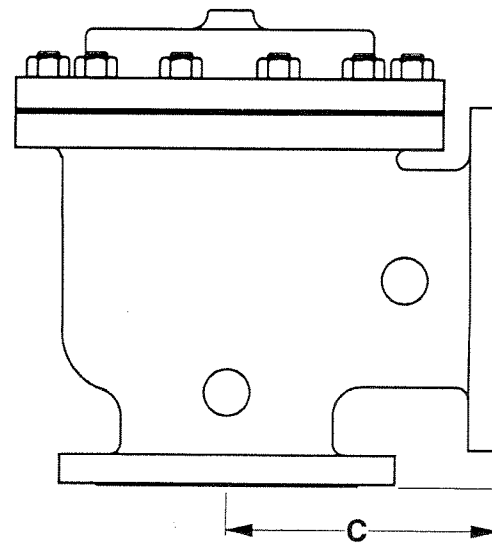

NOTE: 3" VALVE DIMENSIONS ARE FOR NEW MODEL 3100

4" VALVE DIMENSIONS ARE FOR NEW MODEL 4400

REV. A SDJ 6-6-02
REV. B SDJ 2-3-03

TOLERANCES		 OCV Control Valves TULSA, OKLAHOMA U.S.A.	
UNLESS NOTED FRACTIONAL ±1/64 DECIMAL ±.005 MACH. FINISH 125/ ANGULAR ±1/2°			
DRAWN BY SDJ		GENERAL VALVE DIMENSIONS	
DATE 10-6-97		SIZE A	DRAWING NUMBER 65D
CHKD. BY DATE		REV. B	

differential control pilot

installation, operating, and maintenance instructions

model 1356

GENERAL DESCRIPTION

The Model 1356 Differential Control Pilot is a normally-closed, direct-acting, spring-loaded, diaphragm-type control pilot. It is designed primarily for use in systems using LPG or other high vapor pressure liquids to maintain valve inlet pressure a constant, preset amount higher than storage tank vapor pressure in order to prevent flashing in the system. It is manually adjustable by means of an adjustment screw located under the cap on top of the pilot. It is a constant throttling device, maintaining precise positive control of the Main Valve.

FUNCTIONAL DESCRIPTION

Basically, the Model 1356 controls the amount of pressure in the upper chamber of the main valve, hence, the degree of opening or closing of the main valve. The main valve inlet pressure is sensed under the pilot diaphragm and balances against both tank vapor pressure and spring loading above the diaphragm. As valve inlet pressure increases (or vapor pressure decreases), the pilot opens wider, decreasing the pressure in the upper chamber of the main valve and allowing it to open a proportionate amount in order to maintain a constant differential. As valve inlet pressure decreases (or vapor pressure increases), the pilot begins to close, increasing the pressure in upper chamber of the main valve and allowing it to close. This is a constant modulating action compensating for any changes in either inlet pressure or vapor pressure.

INSTALLATION & ADJUSTMENT

The Model 1356 should be installed in the Main Valve Control Piping between the ejector and the downstream body tap. Flow should be in the direction indicated by the arrow on the pilot body. A sensing line (1/4" O.D. tubing) should be installed from the pilot high pressure sensing port (see drawing) to a point upstream of the main valve. A

second sensing line should be installed from the pilot low pressure sensing port to a point on the storage tank located to sense vapor pressure. To aid in accurate setting of the pilot, two pressure gauges—one measuring inlet pressure and one measuring vapor pressure—should be installed. Prior to start up, set the pilot to its fully closed position by turning the adjustment screw all the way clockwise. Start the pump. At this point the main valve will be fully closed or else open slightly, flowing at an inlet pressure higher than desired. Turn the adjustment screw slowly counterclockwise until inlet pressure falls to the desired point in excess of vapor pressure.

Tighten the lock nut on the adjustment screw and reinstall the cap. If adjustments are needed later, turning the adjustment clockwise increases the differential; turning it counterclockwise decreases the differential.

MAINTENANCE

Because of the simplicity of design of the 1356 Pilot, required maintenance is minimal. Fittings and bolts should be periodically checked and the body should be inspected for damage or excessive build-up of foreign material.

TROUBLESHOOTING

Troubleshooting the 1356 is equally simple. Major troubleshooting points are as follows:

1. To check for a ruptured diaphragm, disconnect the low pressure sense line from the pilot. Plug this line to prevent loss of vapor from tank. Pressurize the valve. A continuous discharge of fluid at the open sense port on the pilot indicates a ruptured diaphragm.
2. An indication of the pilot stem binding may be checked by removing the pilot bonnet and moving the stem by hand. If excessive drag is evident, disassemble the pilot and determine the cause.

SPRING CHART		
651701	5-30 PSI	GREEN
651703	20-80 PSI	RED
651704	65-180 PSI	YELLOW
651702	100-300 PSI	BLUE

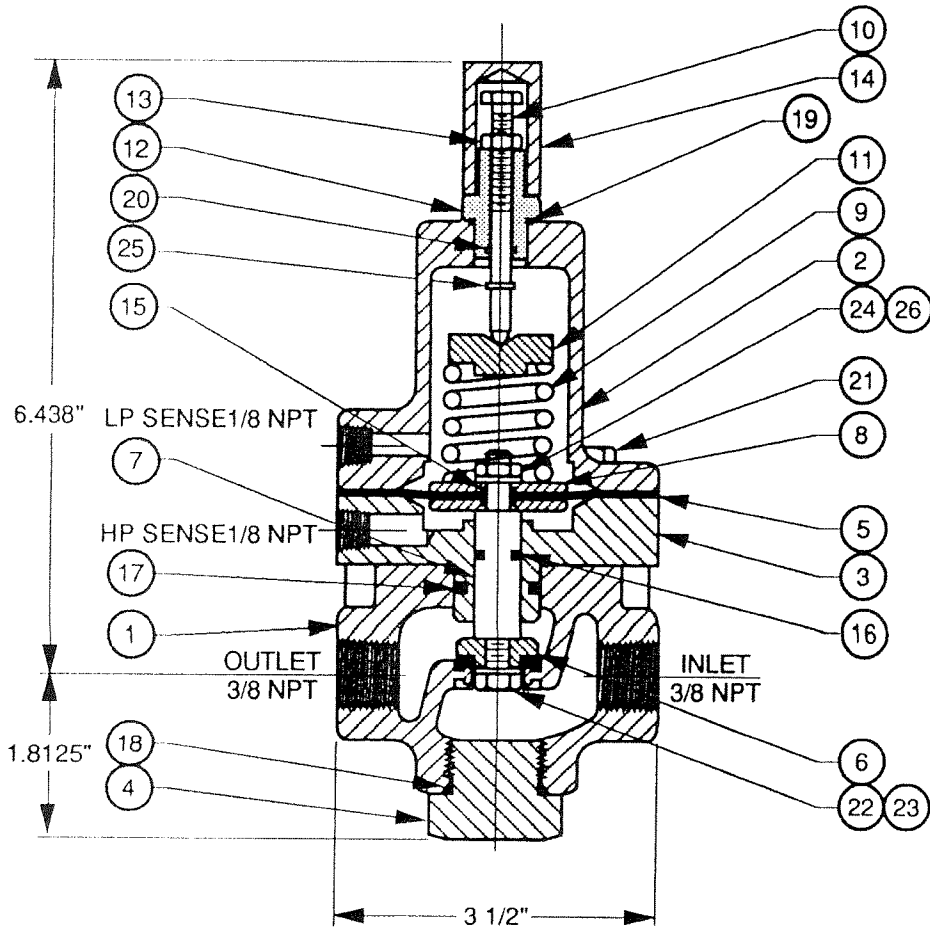

▲ - RECOMMENDED SPARE PARTS
 VITON ELASTOMERS AVAILABLE
 1/2" NPT AVAILABLE

ITEM	PART NO.	QTY	DESCRIPTION	MATERIAL
▲ 26	685700	1	LOCKWASHER	STN. STEEL
25	630715	1	E-RING	STN. STEEL
24	590712	1	HEX NUT	STN. STEEL
▲ 23	685760	1	LOCKWASHER	STN. STEEL
22	531700	1	HEX HD CAPSCREW	STN. STEEL
21	531701	4	HEX HD CAPSCREW	STN. STEEL
▲ 20	611008	2	O-RING	VITON
▲ 19	611906	1	O-RING	VITON
▲ 18	610119	1	O-RING	BUNA-N
▲ 17	611116	1	O-RING	VITON
▲ 16	611012	1	O-RING	VITON
▲ 15	611010	2	O-RING	VITON
14	300137	1	CAP	BRASS
13	300709	1	NUT	STN. STEEL
12	300716	1	ADJ SCREW GUIDE	STN. STEEL
11	300729	1	SPRING RETAINER	STN. STEEL
10	300724	1	ADJUSTING SCREW	STN. STEEL
9	CHART	1	SPRING	STN. STEEL
8	308702	2	DIAPHRAGM PLATE	STN. STEEL
7	314002	1	STEM	MONEL
▲ 6	310703	1	SEAT DISC	BUNA-N/SS
▲ 5	694002	1	DIAPHRAGM	BUNA-N/NYLON
4	310730	1	PLUG	STN. STEEL
3	300719	1	ADAPTER	STN. STEEL
2	304705	1	BONNET	STN. STEEL
1	302702	1	BODY	STN. STEEL

				MATERIAL	TOLERANCES
				STN STL / BUNA-N / MONEL STEM	UNLESS NOTED FRACTIONAL ±1/64 DECIMAL ±.005 MACH. FINISH 125/ ANGULAR ±1/2° ✓
				NO. REQ'D	DRAWN BY RON
				SCALE 1/2	DATE 4-11-95
CHG	E.C. NO.	DATE	BY	CHKD. BY	DATE
REVISIONS			REF DWG NO'S		



OCV Control Valves
TULSA, OKLAHOMA U.S.A.

DIFFERENTIAL CONTROL PILOT

SIZE	DRAWING NUMBER	REV.
A	1356	

DESCRIPTION



MODEL 126 EJECTOR
 The Model 126 ejector is a simple tee fitting with a fixed orifice in its inlet port. It provides the proper supply pressure to the main valve diaphragm chamber, allowing various two-way control pilots to control the valve position.

MODEL 126 EJECTOR DIAGRAM

Brass Construction / Stainless Steel Construction

MATERIAL	PART NUMBER	P (NPT)	T-TUBE O.D.	STD. ORIFICE	USED ON VALVE SIZES
Brass	213100	3/8"	3/8"	.125"	1 1/4"-6"
Brass	214100	1/2"	1/2"	.188"	8"-10"
Brass	215100	3/4"	3/4"	.188"	12"-16"
316 Stn. Steel	213700	1/4"	3/8"	.090"	1 1/4"-6"
316 Stn. Steel	214700	3/8"	1/2"	.125"	8"-10"
316 Stn. Steel	215700	1/2"	3/4"	.188"	12"-16"

Orifice bushings are stainless steel.

STAINLESS

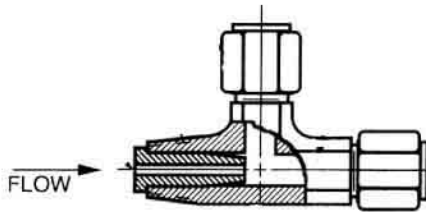

BRASS

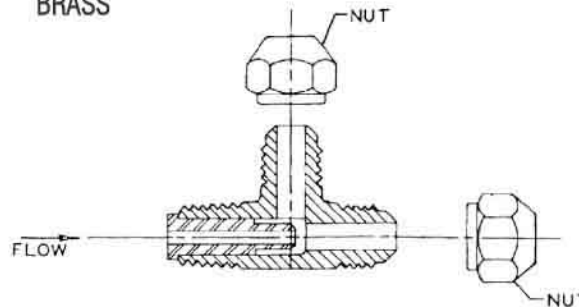

SCHEMATIC SYMBOL

The Model 126 Ejector is shown on OCV Valve Schematics as:

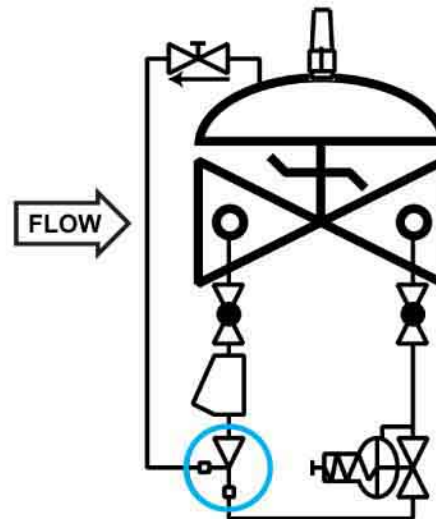
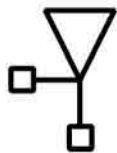

EXAMPLE: Shown here on a MODEL 127-3 Pressure Reducing Valve

DESCRIPTION

The Model 141-2 Needle Valve is an adjustable restriction device installed in the control circuit tubing. The setting of the needle valve meters the flow into and out of the main valve diaphragm chamber, thus controlling the response speed of the main valve. Depending on the application, the needle valve may be used as a closing speed control, opening speed control, or both simultaneously.



◀ Needle Valves shown
Sizes: 3/4" & 1/4"

MODEL 141-2 MATRIX

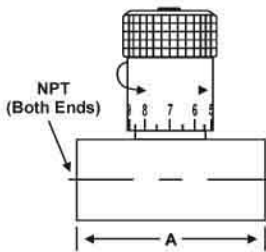

MATERIAL	PART NUMBER	INLET/OUTLET (NPT)	A	USED ON VALVE SIZE*
Brass	683100	1/4	2	1 1/4"-2"
Brass	683101	3/8	2 1/4	2 1/2"-6"
Brass	683102	1/2	2 5/8	8"-10"
Brass	683103	3/4	3 1/4	12"-16"
Stn. Steel	683700	1/4	2	1 1/4"-2"
Stn. Steel	683702	3/8	2 1/4	2 1/2"-6"
Stn. Steel	682704	1/2	2 5/8	8"-10"
Stn. Steel	683703	3/4	3 5/8	12"-16"

Note: Needle valve size may vary on valve application. Consult factory.

SCHEMATIC SYMBOL

The Model 141-2 Needle Valve is shown on OCV Valve Schematics as:

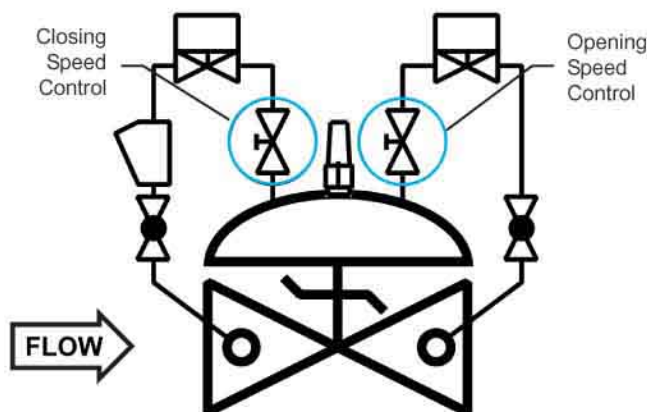
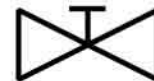

EXAMPLE: Shown here on a MODEL 115-3 DIGITAL VALVE as separate opening and closing speed controls.

DESCRIPTION

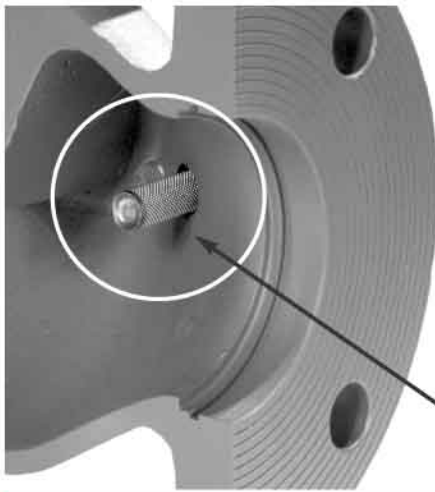

The 123 Inline Strainer installs in the inlet side port of the main valve, and protects the pilot system from solid contaminants in the line fluid. The screen prevents the entrance of particles into the pilot system piping while flow through the main valve washes the screen clean. Recommended use on petroleum valve applications where flushing or removal of the screen for cleaning is not practical or may be considered hazardous.

← Strainer Shown Installed

DIMENSIONS

PART NUMBER	A	B	C	D	E	USED ON VALVE SIZE
660704	3/8	1/4	11/16	2 3/16	1 1/2	1 1/4"-6"
660705	1/2	3/8	7/8	2 1/4	1 1/2	8"-10"
660706	3/4	1/2	1 1/8	2 3/8	1 1/2	12"-16"

MATERIALS

Inline strainers are all-stainless steel construction.

SCREEN SIZE

Standard screen is 40 mesh. Other mesh sizes are available.

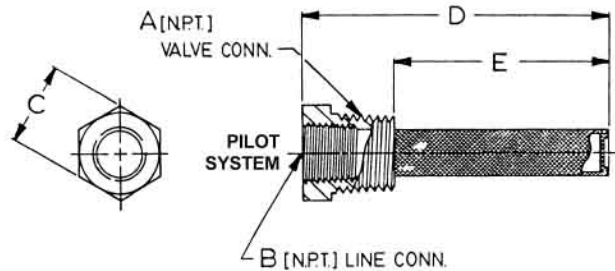

SCHEMATIC SYMBOL

The Model 123 Inline Strainer is shown on OCV Valve Schematics as:

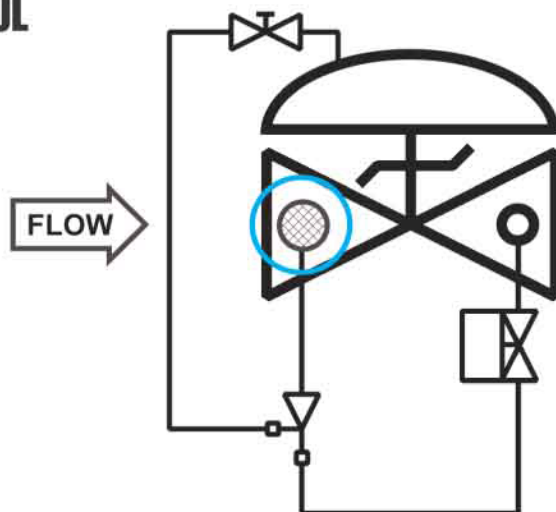

EXAMPLE: Shown here on a MODEL 115-2 Solenoid Valve.

DESCRIPTION

The Model 141-4 Ball Valve is a 1/4-turn shutoff device used for isolating the pilot system from the main valve. They are extremely useful for performing routine maintenance and troubleshooting.

Ball valves are standard on water service valves; optional on fuel service valves.

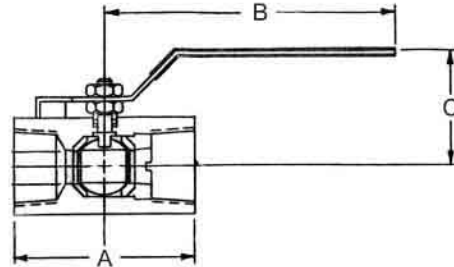

MODEL 141-4 MATRIX

MATERIAL	PART NUMBER	INLET/OUTLET (NPT)	A	B	C	USED ON VALVE SIZE*
Bronze	680100	3/8	1 3/4	3 1/2	1 7/8	1 1/4"-6"
Bronze	680101	1/2	2	3 1/2	2 1/4	8"-10"
Bronze	680102	3/4	3	4 3/4	2 1/4	12"-16"
Stn. Steel	680700	3/8	2	3 3/4	2 1/8	1 1/4"-6"
Stn. Steel	680701	1/2	2 1/4	3 3/4	2 1/2	8"-10"
Stn. Steel	680702	3/4	3	4 3/4	2 1/4	12"-16"

SCHEMATIC SYMBOL

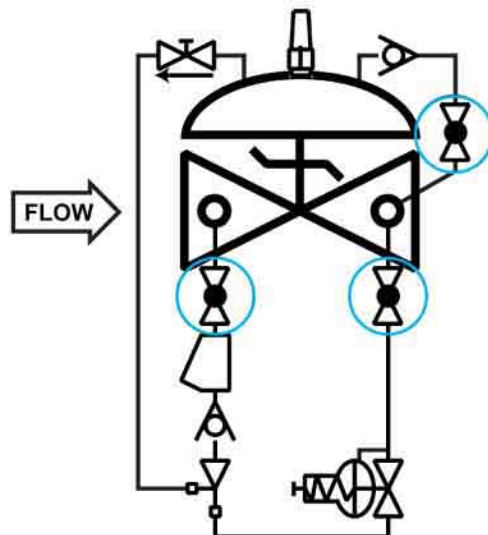

The Model 141-4 Ball Valve is shown on OCV Valve Schematics as:

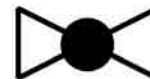

EXAMPLE: Shown here on a MODEL 127-4 Pressure Reducing / Check Valve.

Ball Valve 141-4

DESCRIPTION

The Model 155L Visual Indicator is a device that enables the user to determine the extent of opening of a control valve. It consists of an adaptor threaded into the valve bonnet, a rod threaded into the main valve stem, a sealed Pyrex sight glass, and a protective aluminum housing. The indicator rod moves as the valve opens and closes. The 155L may be installed on virtually any OCV control valve, and can be done so without any disassembly of the valve itself. Since the assembly is not sealed from the diaphragm chamber of the main valve, it provides a convenient point for bleeding air via the 1/8" NPT port located at the top of the sight glass.

WHERE USED - The 155L is the standard visual indicator on fuel service valves. Optional on virtually any control valve not already employing a limit switch or position transmitter.



MODEL 155L MATRIX

MATERIAL	PART NO.	VALVE TRAVEL
1 1/4" - 1 1/2"	255500	3/8"
2"	255500	1/2"
2 1/2"	255500	3/4"
3"	255500	1"
4"	255501	1 3/8"
6" - 8"	255502	1 1/2" - 2"
10"	255503	2 1/2"
12"	255504	3"
14" - 16"	255505	3 1/2", 4"

MAX WORKING PRESSURE: 300 PSI

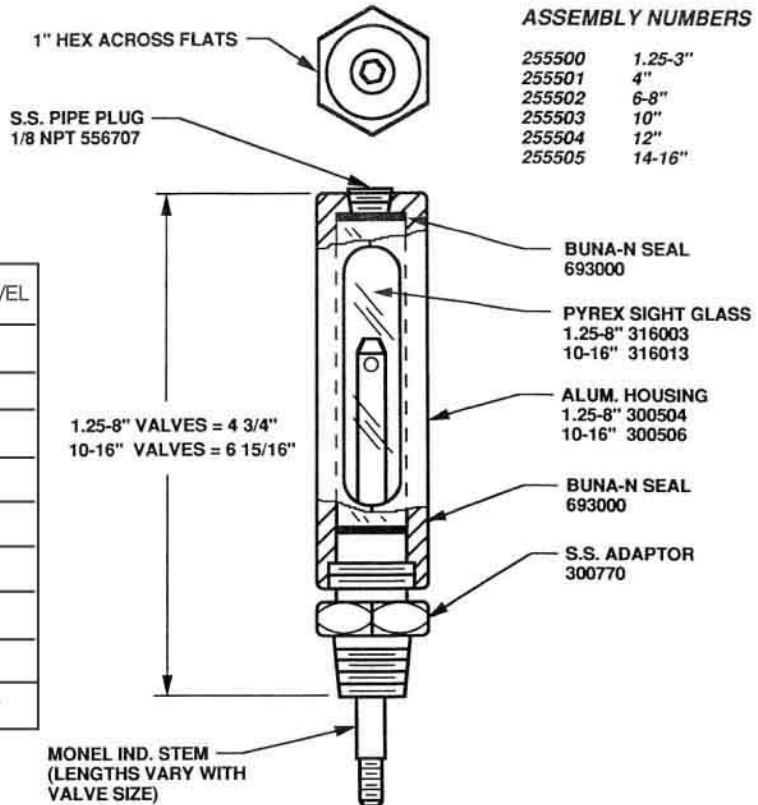

SCHEMATIC SYMBOL

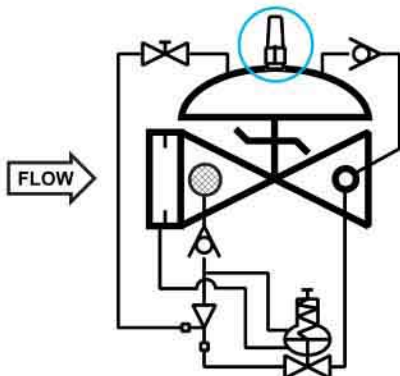

The Model 155L is shown on OCV Valve schematics as:



EXAMPLE: Shown here on a Model 120-6 Rate of Flow / Check Valve.

MATERIALS

- | | |
|--------------------|-----------------|
| Indicator Rod: | Monel |
| Adapter: | Stainless Steel |
| Housing: | Aluminum |
| Sight Glass: | Pyrex |
| Sight Glass Seals: | Buna-N |

Valve Position Indicator (Liquid Filled) 155L