

# OCV Model 8101



High Level Shut-Off Valves



General representation



Fueling



Aviation  
Fueling

## High Level Shut-Off Valve

### Description

The high level shut-off valve shall be installed on the inlet line to the tank and shall close when the high level is reached. The high level shut-off valve shall include a simple, two-way, non-adjustable float pilot to be installed in the tank at the desired tank level and be connected to the main valve by two, customer-installed sense lines. The OCV 8101 is applicable anywhere it is necessary to automatically control the high level in storage tanks where the float pilot can be mounted inside the tank.

### Features & Benefits

- Allows tank filling and shuts off on high level
- Remote-mounted float pilot (inside tank)
- Two field-installed lines between valve and float pilot
- Manual tester available on float pilot
- Can be maintained without removal from the line
- Adjustable response speed
- Factory tested and can be preset to your requirements

### Typical Applications

Commercial Airports



Military Bases



Bulk Fuel Storage Tanks



Truck On/Off Loading



### Certification & Compliance

NSF-ISO Quality System (9001)



FM Approved



Joint Certification Program



UFGS-33 52 43.14 Guide Specifications



CE (Conformité Européenne) Compliance



Fuel Farms



Hydrant Systems



Mobile Refueling Equipment (Carts/Trucks/Tankers)



Refineries



### Operation

The OCV 8101 is designed for tank fill only. A rotary, float-activated pilot controls the position of the main valve. With the float in the full down position, the pilot is wide open, along with the main valve. As the float begins to rise, the pilot begins to restrict flow, causing the main valve to throttle further closed. When fluid level raises the float to the full up position, flow is blocked and the main valve is closed.

### Components

The OCV 8101 consists of the following components, arranged as shown on the schematic diagram:

- 1 Model 65 Basic Valve (fail closed)
- 2 Two-Way Float Pilot
- 3 Ejector
- 4 Needle Valve
- 5 Inline Strainer
- 6 Isolation Ball Valve
- 7 Visual Indicator

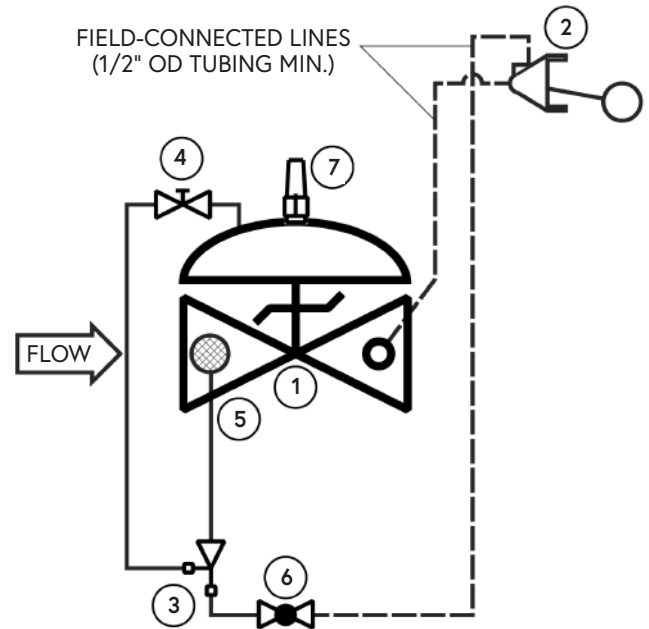

### Pressure Table

End Connections	Ductile Iron	STEEL/SST	STEEL LCB	STEEL WCB	Aluminum
Standard (Maximum Working Pressures at 100°F)					
Screwed	640 psi	640 psi	--	--	285 psi
Grooved	300 psi	300 psi	--	--	200 psi
150# Flanged	250 psi	285 psi	--	--	285 psi
300# Flanged	640 psi	740 psi	--	--	--
Metric (Maximum Working Pressures at 37.78°C)					
Screwed	44.1 bar	44.1 bar	44.1 bar	44.1 bar	19.7 bar
Grooved	20.7 bar	20.7 bar	20.7 bar	20.7 bar	13.8 bar
150# Flanged	17.2 bar	19.0 bar	18.4 bar	19.7 bar	19.7 bar
300# Flanged	44.1 bar	49.6 bar	48.0 bar	51.0 bar	--

Based on ANSI flange ratings.

### Flow Chart

Standard Size Max. Flow (GPM)	1 1/4"	1 1/2"	2"	2 1/2"	3"	4"	6"	8"	10"	12"	14"	16"	18"	20"	24"
7.5 FT/SEC (Military)	40	50	80	120	180	300	680	1200	1850	2650	3200	4150	5250	6550	9400
15 FT/SEC (Max. Recommended)	70	100	160	230	350	600	1350	2350	3700	5250	6350	8300	10500	13100	18800
20 FT/SEC (Max. Continuous)	100	130	210	300	470	800	1800	3150	4950	7000	8450	11100	14000	17400	25100
Metric Size Max. Flow (m <sup>3</sup> /hr)	DN32	DN40	DN50	DN65	DN80	DN100	DN150	DN200	DN250	DN300	DN350	DN400	DN450	DN500	DN600
2.29 M/SEC (Military)	9	11	18	27	41	68	154	272	420	602	726	942	1192	1487	2134
4.57 M/SEC (Max. Recommended)	16	23	36	52	79	136	306	533	840	1192	1441	1884	2384	2974	4268
6.10 M/SEC (Max. Continuous)	23	30	48	68	107	182	409	715	1124	1589	1918	2520	3178	3950	5698

The OCV 8101 is normally sized to match the meter size; however, in no case should the maximum velocity exceed 20 ft/sec (metric: 6.10 meters/sec).

Resetting, maintenance and periodic testing instructions must be followed as described in detail in the applicable OCV IOM (Installation, Operation & Maintenance) Manual.

### Typical Materials

Part	Standard Material
Body/Bonnet	Ductile Iron (epoxy coated), Carbon Steel (epoxy coated), Stainless Steel, Aluminum
Seat Ring	Stainless Steel, Bronze
Stem	Stainless Steel, Monel
Spring	Stainless Steel
Diaphragm	Buna-N, Viton (Nylon reinforced)
Seat Disc	Buna-N, Viton
Pilot	Stainless Steel, Bronze
Other Pilot System Components	Stainless Steel, Bronze/Brass
Tubing & Fittings	Stainless Steel, Copper/Brass

### General Arrangement & Dimensions

Standard Sizes													
DIM	END CONN.	1 1/4" - 1 1/2"	2"	2 1/2"	3"	4"	6"	8"	10"	12"	14"	16"	24"
A	SCREWED	8 3/4	9 7/8	10 1/2	13	---	---	---	---	---	---	---	---
	GROOVED	8 3/4	9 7/8	10 1/2	13	15 1/4	20	---	---	---	---	---	---
	150# FLGD	8 1/2	9 3/8	10 1/2	12	15	17 3/4	25 3/8	29 3/4	34	39	40 3/8	62
	300# FLGD	8 3/4	9 7/8	11 1/8	12 3/4	15 5/8	18 5/8	26 3/8	31 1/8	35 1/2	40 1/2	42	63 3/4
C ANGLE	SCREWED	4 3/8	4 3/4	6	6 1/2	---	---	---	---	---	---	---	---
	GROOVED	4 3/8*	4 3/4	6	6 1/2	7 5/8	---	---	---	---	---	---	---
	150# FLGD	4 1/4	4 3/4	6	6	7 1/2	10	12 11/16	14 7/8	17	---	20 13/16	---
	300# FLGD	4 3/8	5	6 3/8	6 3/8	7 13/16	10 1/2	13 3/16	15 9/16	17 3/4	---	21 5/8	---
D ANGLE	SCREWED	3 1/8	3 7/8	4	4 1/2	---	---	---	---	---	---	---	---
	GROOVED	3 1/8*	3 7/8	4	4 1/2	5 5/8	---	---	---	---	---	---	---
	150# FLGD	3	3 7/8	4	4	5 1/2	6	8	11 3/8	11	---	15 11/16	---
	300# FLGD	3 1/8	4 1/8	4 3/8	4 3/8	5 13/16	6 1/2	8 1/2	12 1/16	11 3/4	---	16 1/2	---
E	ALL	6	6	7	6 1/2	8	10	11 7/8	15 3/8	17	18	19	27
F (OPT)	ALL	3 7/8	3 7/8	3 7/8	3 7/8	3 7/8	3 7/8	6 3/8	6 3/8	6 3/8	6 3/8	6 3/8	8
H	ALL	10	11	11	11	12	13	14	17	18	20	20	28 1/2

Metric Sizes													
DIM	END CONN.	DN32-40	DN50	DN65	DN80	DN100	DN150	DN200	DN250	DN300	DN350	DN400	DN600
A	SCREWED	222	251	267	330	---	---	---	---	---	---	---	---
	GROOVED	222	251	267	330	387	508	---	---	---	---	---	---
	150# FLGD	216	238	267	305	381	451	645	756	863	991	1026	1575
	300# FLGD	222	251	283	324	397	473	670	791	902	1029	1067	1619
C ANGLE	SCREWED	111	121	152	165	---	---	---	---	---	---	---	---
	GROOVED	111*	121	152	165	194	---	---	---	---	---	---	---
	150# FLGD	108	121	152	152	191	254	322	378	432	---	529	---
	300# FLGD	111	127	162	162	198	267	335	395	451	---	549	---
D ANGLE	SCREWED	79	98	102	114	---	---	---	---	---	---	---	---
	GROOVED	79*	98	102	114	143	---	---	---	---	---	---	---
	150# FLGD	76	98	102	102	140	152	203	289	279	---	398	---
	300# FLGD	79	105	111	111	148	165	216	306	298	---	419	---
E	ALL	152	152	178	165	203	254	302	391	432	457	483	686
F (OPT)	ALL	98	98	98	98	98	98	162	162	162	162	162	203
H	ALL	254	279	279	279	305	330	356	432	457	508	508	724

\*Grooved End not available in 1 1/4" (DN32).

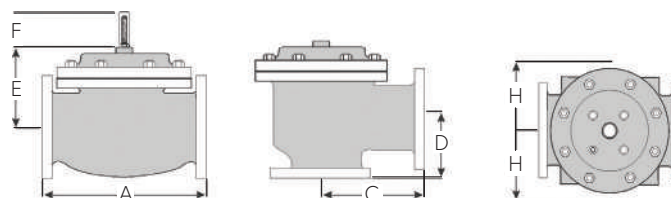

### Technical Data

Temperature (Elastomers)	
Buna-N	-40°F to 180°F
Viton	20°F to 230°F
Fluorosilicone	-40°F to 150°F
EPDM	0°F to 230°F
Sizes	
Screwed Ends	1-1/4" - 3"
Grooved Ends	1-1/2" - 6" (globe & angle)
Flanged Ends	1-1/4" - 24" (globe); 1-1/4" - 16" (angle)
Pressure Rating (ANSI at 100°F)	
250psi for Class 150# ANSI Flanged Ductile Iron	
285psi for Steel/Stainless Steel & Aluminum	
300# ANSI Flanges are available	
Solenoid Voltage	
Enclosure	Explosion Proof NEMA 4X, 6P, 7, 9
Body	Brass, Stainless Steel
Voltages	24, 120, 240, 480 VAC; 12, 24 VDC

Body & Cover Material
Ductile Iron
Carbon Steel
Stainless Steel
Aluminum
Trim Material
Bronze/Brass
Stainless Steel
Copper
Optional Components
Two-Stage Opening
Visual Indicator
Pre-Wired Junction Box
Items to Specify
Fluid Type
Model Number
Size
Body & Trim Material
Solenoid Voltage
Globe or Angle
Special Installation Requirements

### Engineering Specifications

The high level shut-off valve shall be a single-seated, line pressure operated, diaphragm actuated, pilot controlled globe valve. The valve shall seal by means of a corrosion-resistant seat and a resilient, rectangular seat disc. These, and other parts, shall be replaceable without removing the valve from the line. The stem of the main valve shall be guided top and bottom by integral bushings. Alignment of the body, bonnet and diaphragm assembly shall be by precision dowel pins. The diaphragm shall not be used as a seating surface, nor shall the pistons be used as an operating means. The pilot system shall include a speed control, an inline strainer, and an isolation ball valve. The float pilot shall be furnished separately for remote mounting in the tank. The high level shut-off valve shall be

operationally and hydrostatically tested prior to shipment. The main valve body and bonnet shall be ductile iron. All ferrous surfaces shall be coated with 4 mils of epoxy. The main valve seat ring shall be stainless steel. Elastomers (diaphragms, resilient seats and o-rings) shall be Buna-N. The float pilot shall be stainless steel, as shall the 5" spherical float, pilot system accessories, and control line tubing. The high level shut-off valve shall be suitable on <voltage> (see Technical Data section). The high level shut-off valve shall be suitable for pressures of <X to X> psi (see Pressure Table) at flow rates up to <X> gpm (see Flow Chart). The high level shut-off valve shall be an OCV 8101, as manufactured by OCV, Tulsa, OK, USA.