

▲ Model 125-27 shown

The OCV Series 125 and 126 Pump Control Valves are designed to effectively eliminate the surges associated with the starting and stopping of the pump. Electrically interfaced with the pump motor, the valve opens and closes at an adjustable speed, providing a smooth, predictable transition of pump discharge pressure and volume into the system.

## SERIES FEATURES

- ▶ Valve opening speed is adjustable to pump and system requirements for smooth increase in pressure.
- ▶ Valve closing speed is adjustable, gradually decreasing pressure to system as valve closes.
- ▶ Valve is interlocked with pump motor to perform unified pump and valve operation.
- ▶ Built-in reverse flow check feature. ( On 125 & 125-27 )
- ▶ Valve automatically shuts off pump motor on loss of pump discharge pressure (shaft lock-up).
- ▶ Two simple field adjustments: opening speed and closing speed.

## VALVE FEATURES

- ▶ Operates automatically off line pressure.
- ▶ Heavy-duty, nylon-reinforced diaphragm.
- ▶ Rectangular-shaped, soft seat seal provides drip-tight Class VI closure.
- ▶ Diaphragm assembly Guided top and bottom
- ▶ Throttling seat retainer for flow and pressure stability.
- ▶ Easily maintained without removal from the line.
- ▶ Replaceable seat ring.
- ▶ Alignment pins assure proper reassembly after maintenance.
- ▶ Valves are factory tested.
- ▶ Valves are serial numbered and registered to facilitate replacement parts and factory support.

## 125 BOOSTER PUMP CONTROL

Models 125 and 125-27, designed primarily for booster pumps, are installed inline, on the discharge of the pump. These valves also include a check feature that eliminates any need for a separate pump check valve.

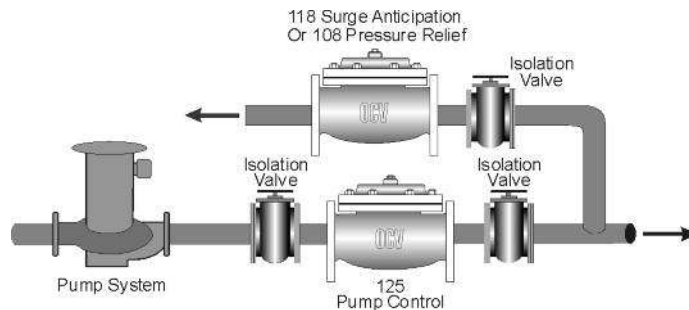

## 126 DEEP WELL PUMP CONTROL

Model 126, designed for deep well pumps, is installed on a bypass line between the pump discharge and the pump check valve. The Model 126 eliminates debris and air on pump start.

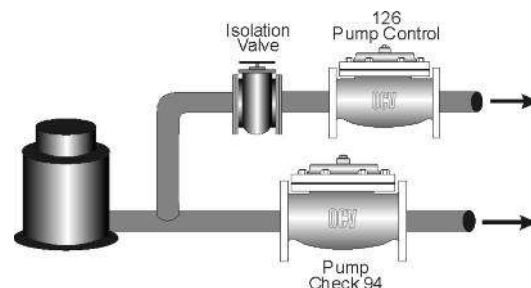

## VALVE OPERATION

Models 125 and 125-27, designed primarily for booster pumps, are installed inline, on the discharge of the pump. They are normally closed with the pump off, open slowly after the pump starts, and close slowly prior to pump shutdown. In this way, flow is slowly and smoothly transitioned to and from the system. These valves also include a check feature that will close the valve in the event of a power failure while the pump is running. Thus, they eliminate any need for a separate pump check valve.

Model 126, designed for deep well pumps, is installed on a bypass line between the pump discharge and the pump check valve, and discharges either to waste or back into the well itself. It is normally open with the pump off, closes slowly after the pump starts, and opens slowly prior to pump shutdown. In this way, flow is slowly and smoothly transferred from the bypass to the system, and vice-versa.

VALVE CHARACTERISTICS - Table 1

	MODEL 125	MODEL 125-27	MODEL 126
CONSTRUCTION	SINGLE CHAMBER	DUAL CHAMBER	DUAL CHAMBER
INSTALLS	INLINE	INLINE	BYPASS
POS. W/ PUMP OFF	CLOSED	CLOSED	OPEN
VALVE DISCHARGES TO	SYSTEM	SYSTEM	ATMOSPHERE
BONNET EXHAUSTS TO	VALVE OUTLET	DRAIN	DRAIN
USE ON BOOSTER PUMPS	YES	YES	NO
USE ON WELL PUMPS	LIMITED	LIMITED	YES
MODULATING PILOTS	YES	NO	RELIEF ONLY
CHECK FEATURE	HYDRAULIC (LIFT CHECK OPT.)	LIFT CHECK*	N/A
PRESSURE LOSS	MED. TO LOW	LOW	N/A
MAX. PRESSURE	740 PSI	400 PSI	400 PSI
TYPICAL SIZE	LINE SIZED	LINE SIZED	<LINE SIZED

\*Lift check closes valve *before* pressure reversal

## ELECTRICAL

A certain amount of components and wiring are required to interface the valve and pump. The wiring diagram below is typical for Series 125. Series 126 is similar but with minor variation to the limit switch. (consult factory for specific diagram) To make the interface quick and simple, the OCV Pump Commander may be added to your installation. This pre-wired controller is available in various models depending upon the level of control and sophistication required.

## TYPICAL WIRING DIAGRAM

- Series 125;
- SOL = SOLENOID PILOT (ON VALVE)
  - LS = LIMIT SWITCH, SPDT (ON VALVE)
  - CR1, CR2 = CONTROL RELAY, DPDT
  - TD1\* = TIME DELAY RELAY, DPDT, ON-DELAY
  - TD2\*\* = TIME DELAY RELAY, DPDT, ON-DELAY (OPTIONAL)
  - HOA = HAND-OFF-AUTO-SWITCH
  - RS = REMOTE START SWITCH
  - MSR = PUMP MOTOR STARTER RELAY

\*TD1 shuts pump down if valve does not open  
 \*\*TD2 if used, delays valve opening for predetermined time period

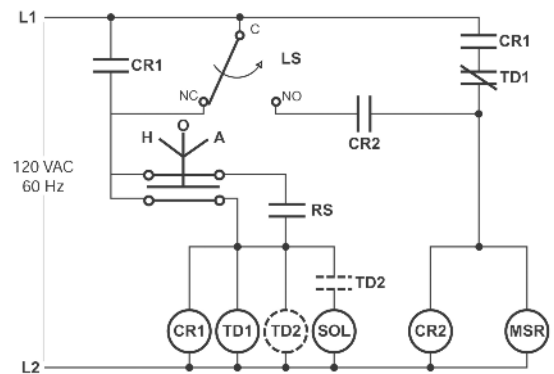

## SELECTION OF PUMP CONTROL VALVES

Selecting and sizing the correct model of pump control valve begins with the pump itself. Refer again to Table 1.

Pumps such as split-case centrifugals, or flooded suction turbines, commonly referred to as booster pumps, will use the Series 125.

Well pumps, such as vertical turbines or submersibles, may use either the Series 125 or the 126. To determine which, first consult with the pump manufacturer. If the pump is designed to start against a closed valve, use the Series 125. If the pump is designed to be started against an open valve, the choice is Model 126. If there is no preference, consider the characteristics of the well itself. Deeper wells, those with a significant air column, and those producing a significant amount of sand will benefit most from the Model 126. Relatively shallow, clean wells can use the Series 125.

If you have opted for the Series 125 booster pump control valve, your next step will be to choose between the single-chambered 125 and the dual-chambered 125-27. Certain factors can make this choice an easy one. For example, if you want to add modulating control pilots to the valve (e.g. pressure reducing, pressure sustaining), or if the maximum pressure (typically pump shut off pressure) is greater than 400 psi, your only choice will be the single-chambered valve. On the other hand, the chief advantage of the 125-27 is that of typically lower pressure loss. Now the choice is closely tied in with sizing.

TOLL FREE 1.888.628.8258 • phone: (918)627.1942 • fax: (918)622.8916 • 7400 East 42nd Place, Tulsa, Oklahoma 74145  
 email: sales@controlvalves.com • website: www.controlvalves.com

Global performance. Personal touch.

## SIZING

### Sizing of Series 125 Valves - Booster Pump Control

1. Decide whether a globe or angle valve will best fit your installation. Keep in mind that it is always best to install any control valve "bonnet up," particularly in sizes 8" and larger.
2. Begin with a line sized valve, i.e., the same size as the pump discharge.

Calculate the pressure drop from the formula,

$$DP = sg \left( \frac{Q}{C_v} \right)^2$$

where: DP = pressure drop, psi  
 sg = specific gravity of line fluid (water = 1.0)  
 Q = rated flow of pump, gpm  
 Cv = Valve coefficient from Table 2.

3. The pressure drop calculated is that for a wide-open apply and would be true for the dual-chambered 125-27 valve regardless of flow rate. On the other hand, the single-chambered valve may not be wide open. Refer to the "wide open at" column of Table 2. If the flow rate is less than this figure, the pressure drop of the single-chambered valve can be 2-3 psi higher than the value calculated in Step 2. If the flow rate is higher than the figure given, the single-chambered valve will be wide open and will have a pressure drop equal to the dual-chambered valve.
4. Check to see that the flow velocity does not exceed 20 ft/sec. If it does, or if the pressure drop is excessive, consider using the next size larger valve.
5. Finally, if the 125-27 valve is selected, make note of the diaphragm chamber discharge. This quantity of water will be discharged to atmosphere each time the valve opens or closes. Provision should be made to drain or otherwise dispose of this water.

### FLOW CHARACTERISTICS - Table 2

SIZE	CV (GLOBE)	CV (ANGLE)	FLOW @20 FT/SEC(GPM)	FLOW @30 FT/SEC(GPM)	WIDE OPEN AT:(GPM)	DIAPH. CHAMBER DISCHARGE(GALLONS)
1 1/4	23	30	85	127	50	0.02
1 1/2	27	35	120	180	50	0.02
2	47	65	210	315	100	0.05
2 1/2	68	87	300	450	140	0.06
3	120	160	460	690	220	0.10
4	200	270	800	1200	400	0.2
6	450	550	1800	2700	950	0.6
8	760	1000	3100	4650	1300	1.0
10	1250	1600	4900	7350	2000	2.5
12	1940	2400	7000	10,500	2800	4.0
14	2200	--	8450	12,700	3300	6.5
16	2850	4000	11,000	16,500	4500	9.6
24	6900	--	25,000	37,500	9300	28.0

### Sizing of Series 126 Valves - Deep Well Pump Control

1. Decide whether a globe or angle valve will best fit your installation. Keep in mind that it is always best to install any control valve "bonnet up," particularly in sizes 8" and larger.
2. Carefully examine your pump curve. Make note of the flow rate at which the pump discharge pressure is reduced to a point just below system static pressure.
3. Calculate the required valve CV from the formula:

$$C_v = \frac{Q}{\sqrt{P_s / sg}}$$

where: Q = flow rate as determined in Step 2, gpm  
 PS = system static pressure, psi  
 sg = specific gravity of line fluid (water = 1.0)

4. Using either the globe or angle valve column of Table 2, pick the smallest size valve that has a CV at least equal to that calculated in Step 3.
5. Using the flow rate determined in Step 2, make sure the velocity does not exceed 30 ft/sec.
6. Finally, make note of the diaphragm chamber discharge. This quantity of water will be discharged to atmosphere each time the valve opens or closes. Provision should be made to drain or otherwise dispose of this water.

**TOLL FREE 1.888.628.8258** • phone: (918)627.1942 • fax: (918)622.8916 • 7400 East 42nd Place, Tulsa, Oklahoma 74145  
 email: sales@controlvalves.com • website: www.controlvalves.com

## VALVE SELECTION GUIDE

By combining various control pilots, multiple valve functions can be performed on a single Series 125 or 126 Pump Control Valve. To find the combination function valve, select the desired features and then the model number. This chart shows only a sample of those most often specified valves. Consult the factory for specific data on the model you selected.

Combination valves can often reduce or eliminate other equipment. Example: If the system requires a Pump Control and a Pressure Sustaining Valve, the sustaining feature can be added as a function of the Pump Control Valve, Model 125-13.

Feature	125	125-2	125-13	125-13E	125-14	125-15	125-18	125-7	125-27	125-8	125-134	125-137	125-157	125-1347	126	126-3	Definition
Power-Actuated Main Valve		X						X							X	X	Dual diaphragm chambers assure full opening at any flow rate, thus minimum pressure loss
Pressure Relief																X	Limits pump discharge pressure to predetermined maximum.
Suction Pressure Sustaining			X														Maintains minimum pump suction pressure
Pressure Sustaining		X								X	X		X				Maintains minimum pump discharge pressure
Lift Check							X	X			X	X	X				Internal assembly closes valve before pressure reversal
Pressure Reducing				X						X			X				Controls valve outlet pressure.
Rate Of Flow Control					X							X					Limits flow rate to preset adjustable setting
Pump Differential Control						X											Keeps pump at most efficient point on curve when suction pressure varies
Controlled Closing Check Feature									X								Controls valve closing on power failure or pump failure

## ABOUT YOUR VALVE

OCV Control Valves was founded more than 60 years ago with a vision and commitment to quality and reliability. From modest beginnings, the company has grown to be a global leader just a half century later. In fact, OCV Valves can be found in some capacity in nearly every country around the world from fire protection systems in Malaysia to aircraft fueling systems in Africa and from oil refineries in Russia to water supply systems in the USA and Canada. You will also find our valves in irrigation systems in Europe, South America and the Middle East.

The original foundation on which the company was built allows our team of professionals to not only provide the service required to be a worldwide supplier, but more importantly the opportunity to afford the personal touch necessary to be each of our customers' best partner. Simply stated, we take pride in all that we do.

Committed to the work they do, our employees average over 15 years of service. This wealth of knowledge allows us to provide quality engineering, expert support, exacting control and the know-how to create valves known for their long life.

Being ISO 9001 certified means we are committed to a quality assurance program. Our policy is to supply each customer with consistent quality products and ensure that the process is right every time. Our valves meet and exceed industry standards around the world. Including approvals by:



Check individual models for availability.

All valves are not created equal. OCV Control Valves proves that day in and day out. We stand behind our valves and are ready to serve your needs.

**TOLL FREE 1.888.628.8258** • phone: (918)627.1942 • fax: (918)622.8916 • 7400 East 42nd Place, Tulsa, OK 74145  
 email: sales@controlvalves.com • website: www.controlvalves.com

## SPECIFICATIONS

NOTE: ALL waterworks valves meet the Low-Lead laws of the United States, including individual state laws, as of March 2014.



Certified to  
NSF/ANSI 61-G & 372

VALVE BODY & BONNET	DUCTILE IRON	CAST STEEL	STAINLESS STEEL
<b>Material Specification</b>	ASTM A536/65-45-12 (epoxy coated)	ASTM A216/WCB (epoxy coated)	ALL GRADES
<b>END CONNECTIONS</b>			
Flange Standard (also available in metric)	ANSI B16.42		ANSI B16.5
Flange Class	150#	300#	150# 300#
Flange Face	Flat	Raised	Raised Raised
Maximum Working Pressure	250 psi	640 psi	285 psi 740 psi
Screwed Working Pressure: ANSI B1.20.1 640 psi		Grooved End Working Pressure: 300 psi	
<b>INTERNALS</b>			
Stem	STAINLESS STEEL		
Spring	STAINLESS STEEL		
Spool	DUCTILE IRON (epoxy coated) / OPTIONAL - STN. STL.		STAINLESS STEEL
Seat Disc Retainer	DUCTILE IRON (epoxy coated) (10" & LARGER) STN. STL. (8" & SMALLER / OPTIONAL - ALL SIZES)		STAINLESS STEEL
Diaphragm Plate	DUCTILE IRON (epoxy coated) / OPTIONAL - STN. STL.		STAINLESS STEEL
Seat Ring (Trim)	LOW-LEAD BRONZE OR STN. STL.		STN. STL.
Upper Stem Bushing	BRONZE OR TEFLON®		TEFLON®
Lower Stem Bushing	NOT APPLICABLE FOR LOW-LEAD BROZE SEAT RINGS / TEFLON FOR FOR STN. STL. SEAT RINGS		
<b>ELASTOMER PARTS (Rubber)</b>			
Diaphragm/Seat Disc/O-Rings	EPDM		
Operating Temperature*	32°F to 230°F		
*Consult factory when temperatures approach low or high temperature allowance.			
<b>COATINGS</b> NSF-61 EPOXY COATING			
<b>ELECTRICAL SOLENOIDS</b>			
Bodies	BRASS / OPTIONAL - STAINLESS STEEL		
Endlosures	WATER TIGHT, NEMA 1, 3, 4, & 4X		
Power	AC, 60HZ - 24, 120, 240, 480 VOLTS	AC, 50HZ - In 110 VOLT MULTIPLES	DC, 6 12, 24, 240 VOLTS
Operation	ENERGIZE TO OPEN (NORMALLY CLOSED)		DE-ENERGIZE TO OPEN (NORMALLY OPEN)

<b>CONTROL PILOTS</b>		
Bodies	LOW-LEAD BRONZE	STN. STL.
Internal	STAINLESS STEEL	STAINLESS STEEL
Tubing	COPPER	STAINLESS STEEL
Fittings	LOW-LEAD BRASS	STAINLESS STEEL

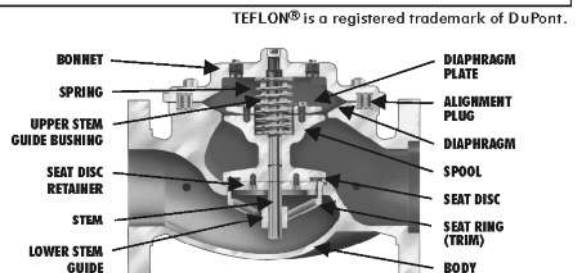

### Globe Flanged Sizes

1.25"	1.5"	2"	2.5"	3"	4"	6"	8"	10"	12"	14"	16"	18"	20"	24"
32mm	40mm	50mm	65mm	80mm	100mm	150mm	200mm	250mm	300mm	350mm	400mm	450mm	500mm	600mm

\*CONSULT FACTORY



### Angle Flanged Sizes

1.25"	1.5"	2"	2.5"	3"	4"	6"	8"	10"	12"	16"
32mm	40mm	50mm	65mm	80mm	100mm	150mm	200mm	250mm	300mm	400mm



### Globe/Angle Screwed Sizes

1.25"	1.5"	2"	2.5"	3"
32mm	40mm	50mm	65mm	80mm



### Globe/Angle Grooved Sizes

1.5"	2"	2.5"	3"	4"	6"
32mm	50mm	65mm	80mm	100mm	150mm*

\*GLOBE ONLY

TOLL FREE 1.888.628.8258 • phone: (918)627.1942 • fax: (918)622.8916 • 7400 East 42nd Place, Tulsa, OK 74145  
email: sales@controlvalves.com • website: www.controlvalves.com

## DIMENSIONS

### U.S. DIMENSIONS - INCHES

DIM	END CONN.	1 1/4-1 1/2	2	2 1/2	3	4	6	8	10	12	14	16	24
A	SCREWED	8 3/4	9 7/8	10 1/2	13	--	--	--	--	--	--	--	--
	GROOVED	8 3/4	9 7/8	10 1/2	13	15 1/4	20	--	--	--	--	--	--
	150# FLGD	8 1/2	9 3/8	10 1/2	12	15	17 3/4	25 3/8	29 3/4	34	39	40 3/8	62
	300# FLGD	8 3/4	9 7/8	11 1/8	12 3/4	15 5/8	18 5/8	26 3/8	31 1/8	35 1/2	40 1/2	42	63 3/4
B	SCREWED	1 7/16	1 11/16	1 7/8	2 1/4	--	--	--	--	--	--	--	--
	GROOVED	1*	1 3/16	1 7/16	1 3/4	2 1/4	3 5/16	--	--	--	--	--	--
	150# FLGD	2 5/16-2 1/2	3	3 1/2	3 3/4	4 1/2	5 1/2	6 3/4	8	9 1/2	10 5/8	11 3/4	16
	300# FLGD	2 5/8-3 1/16	3 1/4	3 3/4	4 1/8	5	6 1/4	7 1/2	8 3/4	10 1/4	11 1/2	12 3/4	18
C	SCREWED	4 3/8	4 3/4	6	6 1/2	--	--	--	--	--	--	--	--
	GROOVED	4 3/8*	4 3/4	6	6 1/2	7 5/8	--	--	--	--	--	--	--
	150# FLGD	4 1/4	4 3/4	6	6	7 1/2	10	12 11/16	14 7/8	17	--	20 13/16	--
	300# FLGD	4 3/8	5	6 3/8	6 3/8	7 13/16	10 1/2	13 3/16	15 9/16	17 3/4	--	21 5/8	--
D	SCREWED	3 1/8	3 7/8	4	4 1/2	--	--	--	--	--	--	--	--
	GROOVED	3 1/8*	3 7/8	4	4 1/2	5 5/8	--	--	--	--	--	--	--
	150# FLGD	3	3 7/8	4	4	5 1/2	6	8	11 3/8	11	--	15 11/16	--
	300# FLGD	3 1/8	4 1/8	4 3/8	4 3/8	5 13/16	6 1/2	8 1/2	12 1/16	11 3/4	--	16 1/2	--
E	ALL	6	6	7	6 1/2	8	10	11 7/8	15 3/8	17	18	19	27
F	ALL	3 7/8	3 7/8	3 7/8	3 7/8	3 7/8	3 7/8	6 3/8	6 3/8	6 3/8	6 3/8	6 3/8	8
G	ALL	6	6 3/4	7 11/16	8 3/4	11 3/4	14	21	24 1/2	28	31 1/4	34 1/2	52
H	ALL	10	11	11	11	12	13	14	17	18	20	20	28 1/2

\*GROOVED END NOT AVAILABLE IN 1 1/4"

### METRIC DIMENSIONS - M.M.

DIM	END CONN.	DN32-DN40	DN50	DN65	DN80	DN100	DN150	DN200	DN250	DN300	DN350	DN400	DN600
A	SCREWED	222	251	267	330	--	--	--	--	--	--	--	--
	GROOVED	222	251	267	330	387	508	--	--	--	--	--	--
	150# FLGD	216	238	267	305	381	451	645	756	864	991	1026	1575
	300# FLGD	222	251	283	324	397	473	670	791	902	1029	1067	1619
B	SCREWED	37	43	48	57	--	--	--	--	--	--	--	--
	GROOVED	25*	30	37	44	57	84	--	--	--	--	--	--
	150# FLGD	59-64	76	89	95	114	140	171	203	241	270	298	406
	300# FLGD	67-78	83	95	105	127	159	191	222	260	292	324	457
C	SCREWED	111	121	152	165	--	--	--	--	--	--	--	--
	GROOVED	111*	121	152	165	194	--	--	--	--	--	--	--
	150# FLGD	108	121	152	152	191	254	322	378	432	--	529	--
	300# FLGD	111	127	162	162	198	267	335	395	451	--	549	--
D	SCREWED	79	98	102	114	--	--	--	--	--	--	--	--
	GROOVED	79*	98	102	114	143	--	--	--	--	--	--	--
	150# FLGD	76	98	102	102	140	152	203	289	279	--	398	--
	300# FLGD	79	105	111	111	148	165	216	306	298	--	419	--
E	ALL	152	152	178	165	203	254	302	391	432	457	483	686
F	ALL	98	98	98	98	98	98	162	162	162	162	162	203
G	ALL	152	171	195	222	298	356	533	622	711	794	876	1321
H	ALL	254	279	279	279	305	330	356	432	457	508	508	724

\*GROOVED END NOT AVAILABLE IN DN32

For maximum efficiency, the OCV control valve should be mounted in a piping system so that the valve bonnet (cover) is in the top position. Other positions are acceptable but may not allow the valve to function to its fullest and safest potential. In particular, please consult the factory before installing 8" and larger valves, or any valves with a limit switch, in positions other than described. Space should be taken into consideration when mounting valves and their pilot systems.

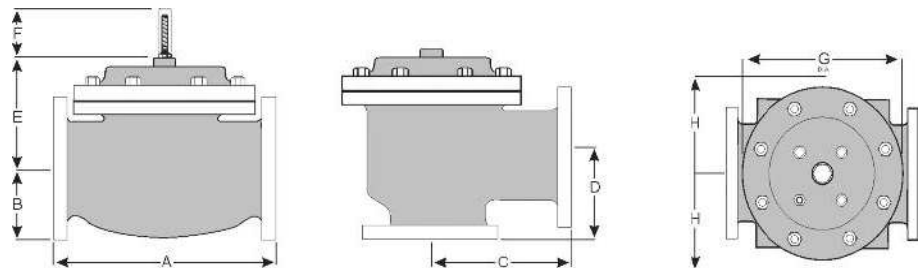

A routine inspection & maintenance program should be established and conducted yearly by a qualified technician. Consult our factory @ **1-888-628-8258** for parts and service.

Represented by:

#### How to order your valve

When Ordering please provide:  
 Series Number - Valve size - Globe or Angle -  
 Pressure Class - Screwed, Flanged, Grooved -  
 Trim Material - Adjustment Range - Pilot  
 Options - Special needs / or installation  
 requirements.

**TOLL FREE 1.888.628.8258** • phone: (918)627.1942 • fax: (918)622.8916 • 7400 East 42nd Place, Tulsa, OK 74145  
 email: sales@controlvalves.com • website: www.controlvalves.com

**Global performance. Personal touch.**