

Model 108-2 ▲

The Model 108-2 has a wide range of applications: anywhere a system must be protected from pressures that are too high (relief) or too low (sustaining).

Typical applications include:

- ▶ Pump systems
- ▶ Fuel distribution systems

SERIES FEATURES

- ▶ Relief Valve: Limits inlet pressure by relieving excess pressure
- ▶ Pressure Sustaining: Prevents inlet pressure from dropping below a predetermined minimum
- ▶ Operates over a wide flow range
- ▶ Inlet pressure is adjustable with a single screw
- ▶ Quick opening; adjustable closing speed
- ▶ Can be maintained without removal from the line
- ▶ Factory tested and can be pre-set to your requirements

OPERATION

The normally closed, spring-loaded pilot, sensing upstream pressure, responds to changes in pressure and causes the main valve to do the same. The net result is a constant modulating action of the pilot and main valve to hold the upstream pressure constant. The pilot system is equipped with a closing speed control that fine tunes the valve response to the system variables.

COMPONENTS

The Model 108-2 consists of the following components, arranged as shown on the schematic diagram:

- 1.) Model 65 Basic Control Valve
- 2.) Model 1330 Pressure Relief/Back Pressure Pilot
- 3.) Model 126 Ejector
- 4.) Model 141-3 Flow Control Valve
- 5.) Model 123 Inline Strainer
- 6.) Model 155L Visual Indicator (optional)

SIZING

Due to static electricity and other concerns, pressure sustaining valves and pressure relief valves that operate frequently should be limited to a maximum velocity of 15 ft/sec. Pressure relief valves that operate intermittently may be extended to 25 ft/sec.

Please consult the factory for definitive sizing assistance.

SCHEMATIC

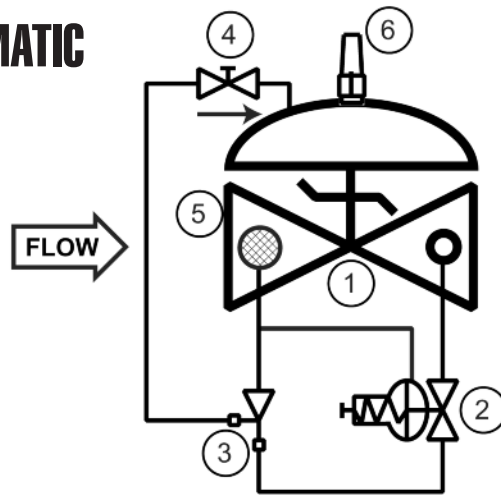

RECOMMENDED INSTALLATION

- ▶ Install the valve with adequate space above and around the valve to facilitate servicing. Refer to the Dimension Table.
- ▶ Valve should be installed with the bonnet (cover) at the top, particularly 8" (DN200) and larger valves, and any valve with a limit switch.
- ▶ Shut-off valves should be installed upstream and downstream of the control valve. These are used to isolate the valve during start-up and maintenance.
- ▶ Install a pressure gauge upstream of the valve to enable adjustment to the required pressure setting. This gauge may be installed in the upstream side port of the valve body.

MAX. PRESSURE

(The pressures listed here are maximum working pressures at 100°F)

END CONNECTIONS	DUCTILE IRON	STEEL/STN STL	ALUMINUM
Threaded	640 psi	640 psi	285 psi
Grooved	300 psi	300 psi	200 psi
150# Flanged	250 psi	285 psi	285 psi
300# Flanged	640 psi	740 psi	---

SIZE	1 1/4", 1 1/2"	2"	2 1/2"	3"	4"	6"	8"	10"	12"	14"	16"	24"
FLOW@15 FPS, GPM	70, 95	155	255	345	600	1350	2340	3690	5240	6330	8260	18800
FLOW@25 FPS, GPM	115-160	260	375	575	1000	2250	3900	6125	8750	10600	13750	31250

Cavitation Note: Relief valves, by their application, are subject to pressure differentials that may induce cavitation. When these conditions exist, it may be only on an intermittent basis, causing minimum concern got valve deterioration. Charts indexing only inlet and outlet pressures do not address the complexity of this phenomenon. OCV can assist you in validating your application.

TOLL FREE 1.888.628.8258 • phone: (918)627.1942 • fax: (918)622.8916 • 7400 East 42nd Place, Tulsa, OK 74145
 email: sales@controlvalves.com • website: www.controlvalves.com

Model 108-2 (Terminal Services)



SIZES

Screwed Ends -	1 1/4" - 3"
Grooved Ends -	1 1/2" - 4" (globe)
	1-1/2" - 4" (angle)
Flanged Ends -	1 1/4" - 24" (globe);
	1 1/4" - 16" (angle)

FLUID OPERATING TEMPERATURE

RANGE (Valve Elastomers)
Buna-N -40°F to 180°F
Viton 20°F to 230°F
Fluorosilicone -40°F to 150°F
EPDM 0°F to 230°F

SPRING RANGES (inlet setting)
5-30 psi, 20-80 psi, 20-200 psi,
100-300 psi

MATERIALS

Consult factory for others.

Body/Bonnet: Ductile Iron (epoxy coated), Carbon Steel (epoxy coated), Stainless Steel, Aluminum

Seat Ring: Stainless Steel, Bronze

Stem: Stainless Steel, Monel

Spring: Stainless Steel

Diaphragm: Buna-N, Viton, (Nylon reinforced)

Seat Disc: Buna-N, Viton

Pilot: Stainless Steel, Bronze

Other pilot system components:

Stainless Steel, Bronze/Brass

Tubeing & Fittings:

Stainless Steel, Copper/Brass

SPECIFICATIONS (Typical Terminal Services Application)

The <pressure relief> <pressure sustaining> valve shall function to <prevent main line pressure from exceeding a predetermined maximum> <prevent the upstream pressure from falling below a predetermined minimum.>

DESIGN

The valve shall be a single-seated, line pressure operated, diaphragm actuated, pilot controlled <globe> <angle> valve. The valve shall seal by means of a corrosion-resistant seat and a resilient, rectangular seat disc. These, and other parts, shall be replaceable without removing the valve from the line. The stem of the main valve shall be guided top and bottom by integral bushings. Alignment of the body, bonnet, and diaphragm assembly shall be by precision dowel pins. The diaphragm shall not be used as a seating surface, nor shall pistons be used as an operating means. The pilot system shall be furnished complete and installed on the main valve. It shall include a closing speed control and an inline strainer. The <pressure relief> <pressure sustaining> valve shall be operationally and hydrostatically tested prior to shipment.

MATERIALS OF CONSTRUCTION

The main valve body and bonnet shall be ductile iron. All ferrous surfaces shall be coated with 4 mils of epoxy. The main valve seat ring shall be stainless steel. Elastomers (diaphragm, resilient seats, and O-rings) shall be Buna-N. Control pilots shall be stainless steel. The closing speed control shall be stainless steel, as shall the control line tubing and fittings.

OPERATING CONDITIONS

The <pressure relief> <pressure sustaining> valve shall be suitable for controlling the inlet pressure to a <maximum> <minimum> of <X> psi at flow rates ranging from <Y to Z> gpm.

ACCEPTABLE PRODUCTS

The <pressure relief> <pressure sustaining> valve shall be a <SIZE> Model 108-2, <globe pattern> <angle pattern> with <150# flanged> <300# flanged> <threaded> <grooved> end connections, as manufactured by OCV Control Valves, Tulsa, Oklahoma, USA.

U.S. DIMENSIONS - INCHES

DIM	END CONN.	1 1/4-1 1/2	2	2 1/2	3	4	6	8	10	12	14	16	24
A	SCREWED	8 3/4	9 7/8	10 1/2	13	--	--	--	--	--	--	--	--
	GROOVED	8 3/4	9 7/8	10 1/2	13	15 1/4	20	--	--	--	--	--	--
	150# FLGD	8 1/2	9 3/8	10 1/2	12	15	17 3/4	25 3/8	29 3/4	34	39	40 3/8	62
C	300# FLGD	8 3/4	9 7/8	11 1/8	12 3/4	15 5/8	18 5/8	26 3/8	31 1/8	35 1/2	40 1/2	42	63 3/4
	SCREWED	4 3/8	4 3/4	6	6 1/2	--	--	--	--	--	--	--	--
	GROOVED	4 3/8*	4 3/4	6	6 1/2	7 5/8	--	--	--	--	--	--	--
D	150# FLGD	4 1/4	4 3/4	6	6	7 1/2	10	12 11/16	14 7/8	17	--	20 13/16	--
	300# FLGD	4 3/8	5	6 3/8	6 3/8	7 13/16	10 1/2	13 3/16	15 9/16	17 3/4	--	21 5/8	--
	SCREWED	3 1/8	3 7/8	4	4 1/2	--	--	--	--	--	--	--	--
E	GROOVED	3 1/8*	3 7/8	4	4 1/2	5 5/8	--	--	--	--	--	--	--
	150# FLGD	3	3 7/8	4	4	5 1/2	6	8	11 3/8	11	--	15 11/16	--
	300# FLGD	3 1/8	4 1/8	4 3/8	4 3/8	5 13/16	6 1/2	8 1/2	12 1/16	11 3/4	--	16 1/2	--
F (OPT)	ALL	6	6	7	6 1/2	8	10	11 7/8	15 3/8	17	18	19	27
	ALL	3 7/8	3 7/8	3 7/8	3 7/8	3 7/8	3 7/8	6 3/8	6 3/8	6 3/8	6 3/8	6 3/8	8
H	ALL	10	11	11	11	12	13	14	17	18	20	20	28 1/2

*GROOVED END NOT AVAILABLE IN 1 1/4"

For maximum efficiency, the OCV control valve should be mounted in a piping system so that the valve bonnet (cover) is in the top position. Other positions are acceptable but may not allow the valve to function to its fullest and safest potential. In particular, please consult the factory before installing 8" and larger valves, or any valves with a limit switch, in positions other than described. Space should be taken into consideration when mounting valves and their pilot systems.

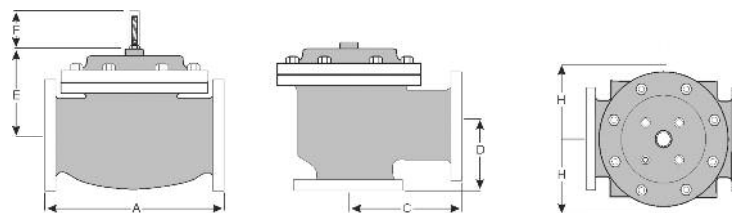

A routine inspection & maintenance program should be established and conducted yearly by a qualified technician. Consult our factory @ 1-888-628-8258 for parts and service.

How to order your Model 108-2 valve

When ordering please provide:

Fluid to be controlled - Model Number - Size - Globe or Angle - End Connection - Body Material - Trim Material - Pilot Options - Flow Rate Setting or Range - Special Requirements / Installation Requirements

Represented by:

TOLL FREE 1.888.628.8258 • phone: (918)627.1942 • fax: (918)622.8916 • 7400 East 42nd Place, Tulsa, Oklahoma 74145
email: sales@controlvalves.com • website: www.controlvalves.com