

Model 119-15 ▲

The Model 119-15 has a very specific purpose: to limit the flow of fuel through a filter separator, close fully in the event of high water levels in the filter separator sump and close to prevent reverse flow. To perform this task, the Model 119-15 must operate in conjunction with one of the OCV 800 Series interface float pilots.

SERIES FEATURES

- ▶ Controls or limits flow to a predetermined rate
- ▶ Built-in orifice plate for sensing flow rate
- ▶ Extra-sensitive differential pilot
- ▶ Flow rate is adjustable with single screw
- ▶ High capacity pilot system provides quick closing on water slug
- ▶ Check feature integral to pilot system
- ▶ Can be maintained without removal from the line
- ▶ Factory tested and can be preset to your requirements
- ▶ Valve position indicator

OPERATION

With little or no water in the sump of the filter separator, the float of the interface pilot is down. The float pilot routes vessel pressure to the bonnet of the three-way auxiliary pilot. This positions the three port auxiliary pilot to connect the bonnet of the main valve downstream, allowing the valve to open. While open, the rate of flow pilot, located in the valve inlet flange, senses the differential across the integral orifice plate and responds to changes in this differential by modulating the main valve to prevent the flow rate from exceeding the predetermined maximum.

With a high water level in the sump of the filter separator, the float of the interface pilot is up. The float pilot vents pressure from the bonnet of the three-way auxiliary pilot, shifting it to apply full inlet pressure to the bonnet of the main valve and drives the valve fully and tightly closed.

Should outlet pressure exceed inlet pressure, the valve's reverse flow check feature will close the valve.

COMPONENTS

The Model 119-15 consists of the following components, arranged as shown on the schematic diagram:

- 1.) Model 65 Basic Control Valve (Fail Closed)
- 2.) Orifice Plate
- 3.) Model A224 Accelerator Pilot
- 4.) Model 2450 Rate of Flow Control Pilot
- 5.) Model 141-3 Flow Control Valve (Opening Speed Control)
- 6A.) Model 141-1 Check Valve
- 6B.) Model 141-1 Check Valve
- 7.) Model 123 Inline Strainer
- 8.) Model 155 Visual Indicator

SIZING

Sizing of the Model 119-15 is typically the same size as the filter separator discharge connection. Definitive sizing information can be found at www.controlvalves.com in the ValveMaster Fuels Sizing & Selection Program, or consult the factory for assistance.

TOLL FREE 1.888.628.8258 • phone: (918)627.1942 • fax: (918)622.8916 • 7400 East 42nd Place, Tulsa, OK 74145
email: sales@controlvalves.com • website: www.controlvalves.com

SCHEMATIC

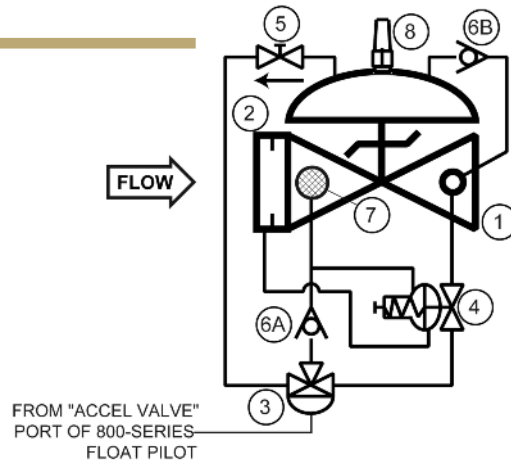

RECOMMENDED INSTALLATION

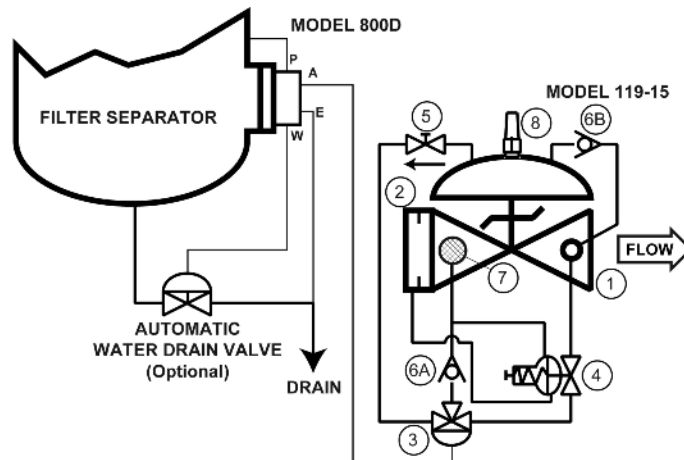

MAX. PRESSURE

Maximum pressure is determined by that of the interface float pilot.

END CONNECTIONS	DUCTILE IRON	STEEL/STN STL	ALUMINUM
150# Flanged	250 psi	285 psi	285 psi
300# Flanged	300 psi	300 psi	---

(The pressures listed here are maximum working pressures at 100°F.)

Model 119-15 (Aviation Fueling)



SIZES GLOBE/ANGLE
 Flanged Ends
 1 1/4" - 24" (globe);
 11/4" - 12", 16" (angle)
FLUID OPERATING TEMPERATURE RANGE
 (Valve Elastomers)
 Buna-N -40°F to 180°F
 Viton 20°F to 230°F
 Fluorosilicone -40°F to 150°F
 EPDM 0°F to 230°F

MATERIALS
 Consult factory for others.
Body/Bonnet: Ductile Iron (epoxy coated), Carbon Steel (epoxy coated), Stainless Steel, Aluminum
Seat Ring: Stainless Steel, Bronze
Stem: Stainless Steel, Monel
Spring: Stainless Steel
Diaphragm: Buna-N, Viton, (Nylon reinforced)
Seat Disc: Buna-N, Viton
Pilot: Stainless Steel, Bronze
Other pilot system components: Stainless Steel, Bronze/Brass
Tubing & Fittings: Stainless Steel, Copper/Brass

SPECIFICATIONS (Typical Aviation Fueling Application)

The filter separator rate of flow/shut-off/check valve shall open and close via hydraulic signals from the interface float pilot, shall limit the flow rate through the filter separator to a predetermined maximum, and shall prevent reverse flow.

DESIGN

The filter separator rate of flow/shut-off/check valve shall be a single-seated, line pressure operated, diaphragm actuated, pilot controlled globe valve. The valve shall seal by means of a corrosion-resistant seat and a resilient, rectangular seat disc. These, and other parts, shall be replaceable without removing the valve from the line. The stem of the main valve shall be guided top and bottom by integral bushings. Alignment of the body, bonnet and diaphragm assembly shall be by precision dowel pins. The diaphragm shall not be used as a seating surface, nor shall the pistons be used as an operating means. The pilot system shall be furnished complete and installed on the main valve. It shall include an orifice plate mounted in the valve inlet flange, rate of flow control pilot, inline strainer, 3-way auxiliary pilot, and valve position indicator. The filter separator rate of flow/shut-off/check valve shall be operationally and hydrostatically tested prior to shipment.

MATERIALS OF CONSTRUCTION

The main valve body and bonnet shall be ductile iron. All ferrous surfaces shall be coated with 4 mils of epoxy. The main valve seat ring shall be stainless steel. Elastomers (diaphragms, resilient seats and O-rings) shall be Buna-N. The control pilots, control line tubing and fittings shall be stainless steel.

OPERATING CONDITIONS

The filter separator rate of flow/shut-off/check valve shall be suitable for pressures of <X to X> psi at flow rates up to <X> gpm.

ACCEPTABLE PRODUCTS

The filter separator rate of flow/shut-off/check valve shall be a <size> Model 119-15, <globe pattern, angle pattern>, with <150# flanged, 300# flanged> end connections, as manufactured by OCV Control Valves, Tulsa, Oklahoma, USA.

U.S. DIMENSIONS - INCHES

DIM	END CONN.	1 1/4-1 1/2	2	2 1/2	3	4	6	8	10	12	14	16	24
A	150# FLGD	8 1/2	9 3/8	10 1/2	12	15	17 3/4 **	25 3/8	29 3/4	34	39	40 3/8	62
	300# FLGD	8 3/4	9 7/8	11 1/8	12 3/4	15 5/8	18 5/8 **	26 3/8	31 1/8	35 1/2	40 1/2	42	63 3/4
B	150# FLGD	2 5/16-2 1/2	3	3 1/2	3 3/4	4 1/2	5 1/2	6 3/4	8	9 1/2	10 5/8	11 3/4	16
	300# FLGD	2 5/8-3 1/16	3 1/4	3 3/4	4 1/8	5	6 1/4	7 1/2	8 3/4	10 1/4	11 1/2	12 3/4	18
C	150# FLGD	4 1/4	4 3/4	6	6	7 1/2	10	12 11/16	14 7/8	17	--	20 13/16	--
	ANGLE	300# FLGD	4 3/8	5	6 3/8	6 3/8	7 13/16	10 1/2	13 3/16	15 9/16	17 3/4	--	21 5/8
D	150# FLGD	3	3 7/8	4	4	5 1/2	6	8	11 3/8	11	--	15 11/16	--
	ANGLE	300# FLGD	3 1/8	4 1/8	4 3/8	4 3/8	5 13/16	6 1/2	8 1/2	12 1/16	11 3/4	--	16 1/2
E	ALL	6	6	7	6 1/2	8	10	11 7/8	15 3/8	17	18	19	27
F (Opt)	ALL	3 7/8	3 7/8	3 7/8	3 7/8	3 7/8	3 7/8	6 3/8	6 3/8	6 3/8	6 3/8	6 3/8	8
G	ALL	6	6 3/4	7 11/16	8 3/4	11 3/4	14	21	24 1/2	28	31 1/4	34 1/2	52
H	ALL	10	11	11	11	12	13	14	17	18	20	20	28 1/2

*GROOVED END NOT AVAILABLE IN 1 1/4"

**Note: for military fueling valves, 6" 150# flanges have 20" face to face dimensions and 6" 300# flanges have 21" face to face dimensions.

For maximum efficiency, the OCV control valve should be mounted in a piping system so that the valve bonnet (cover) is in the top position. Other positions are acceptable but may not allow the valve to function to its fullest and safest potential. In particular, please consult the factory before installing 8" and larger valves, or any valves with a limit switch, in positions other than described. Space should be taken into consideration when mounting valves and their pilot systems.

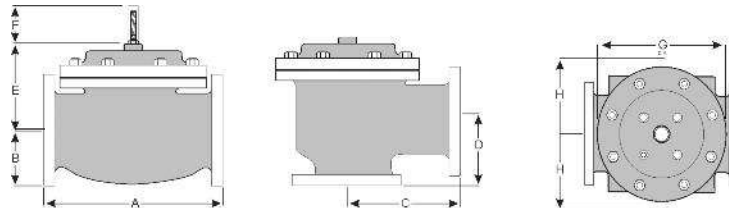

QUALITY SYSTEM
 REGISTERED TO
 ISO 9001

United States/Canada Joint
 Certification Program (JCP)
 Certification Number
 0073030

Represented by:

A routine inspection & maintenance program should be established and conducted yearly by a qualified technician. Consult our factory @ 1-888-628-8258 for parts and service.

How to order your Model 119-15 valve

When ordering please provide:
 • Fluid to be controlled • Model Number •
 Size • Globe or Angle • End Connection •
 Body Material • Trim Material • Flow Rate
 Setting or Range • Special Requirements /
 Installation Requirements

TOLL FREE 1.888.628.8258 • phone: (918)627.1942 • fax: (918)622.8916 • 7400 East 42nd Place, Tulsa, Oklahoma 74145
 email: sales@controlvalves.com • website: www.controlvalves.com