



▲ Model 66TS

The Model 66TS Tank Safety Valve is designed to automatically isolate a fuel storage tank from its loading terminal or product transfer point. Hydraulically linked to the delivery pump, the valve is open only when the pump runs and is effectively producing pressure. The valve will automatically close when the pump is off, fails to produce pressure, or in the event of a line rupture.

SERIES FEATURES

- ▶ Totally hydraulic operation; no electrical connections
- ▶ Dual chamber, full open, low pressure drop design
- ▶ Thermal relief of excess downstream pressure
- ▶ Provides anti-siphon protection
- ▶ Capable of manual operation
- ▶ Can be maintained without removal from the line
- ▶ Valve position indicator standard
- ▶ Factory tested

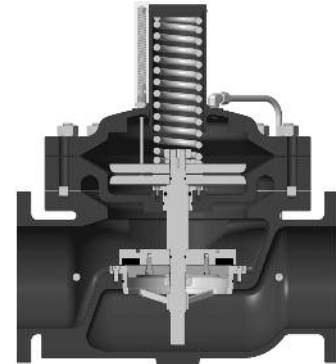

OPERATION

The 66TS is built on a dual diaphragm chamber valve design. It is opened and closed by pressure applied to either side of the diaphragm. The lower chamber receives pressure from pump discharge and acts to open the valve while loss of this pressure allows the valve spring to close the valve.

Opening Cycle-When the pump discharge pressure reaches 5 psi over tank head, the valve begins to open. It is fully open when pump discharge is 15 psi over tank head.

Closing Cycle-Valve closing will start when pump discharge pressure drops for any reason to tank head. This may be due to normal pump shut down, pump failure or line rupture.

Manual Opening- The valve is equipped with an Schrader air valve to enable connection of a pressure source (hand pump, low pressure air bottle, etc.) to open the valve.

Thermal Relief- Pressure buildup of 6-10 psi (above tank head) in the downstream piping will automatically be relieved back through the valve to the tank.

COMPONENTS

- 1.) 66TS Main Valve
- 2.) Ball Valve
- 3.) Schrader Valve
- 4.) Visual Indicator

SIZING

The size of the Model 66TS is typically the same as the pump suction line; however, the velocity through the valve should never exceed 20 ft/second as shown below. Valve pressure drop may be calculated using the Cv values shown. Consult the factory for assistance.

SIZE	2"	3"	4"	6"	8"	10"	12"	16"
MAX. FLOW, GPM	200	460	800	1800	3100	4900	7000	11000
Valve Cv	47	120	200	450	750	1250	1960	2850

CROSS-SECTION DRAWING

RECOMMENDED INSTALLATION

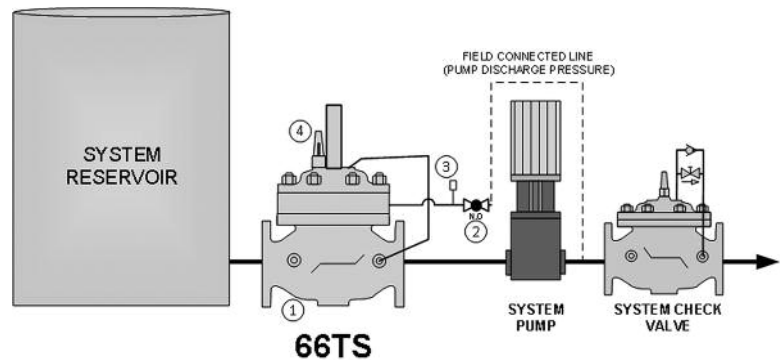

- ▶ Install the proper size sense line from the pump discharge to the valve connection. Based on a valve-to-pump distance of 600 ft., the following schedule 40 pipe sizes are recommended

VALVE SIZE:	2"-3"	4"-6"	8"	10"	12"
SENSE LINE SIZE:	3/8"	3/4"	1"	1 1/4"	1 1/2"

- ▶ Sense line connection at 66TS should have a ball type or positive shut off type valve installed (to facilitate manual opening).
- ▶ To prevent pump cavitation on start-up, pump discharge check valve should be of the slow-opening type to ensure adequate pressure for initial opening of the tank safety valve.
- ▶ Install the valve with adequate space above and around the valve to facilitate servicing. Refer to the Dimension Table.

MAX. PRESSURE

(The pressures listed here are maximum pressures at 100°F)

END CONNECTIONS	DUCTILE IRON	STEEL/STN STL
Threaded	640 psi	640 psi
Grooved	300 psi	300 psi
150# Flanged	250 psi	285 psi
300# Flanged	640 psi	740 psi

TOLL FREE 1.888.628.8258 ● phone: (918)627.1942 ● fax: (918)622.8916 ● 7400 East 42nd Place, Tulsa, OK 74145
 email: sales@controlvalves.com ● website: www.controlvalves.com

SIZES

GLOBE/ANGLE

Screwed Ends: 2" - 3"
 Grooved Ends: 2" - 6" (globe)
 2" - 4" (angle)
 Flanged Ends: 2" - 16" (globe);
 2" - 16" (angle)

FLUID OPERATING TEMPERATURE

RANGE (Valve Elastomers)

Buna-N -40°F to 180°F
 Viton 20°F to 230°F
 Fluorosilicone -40°F to 150°F
 EPDM 0°F to 230°F

MATERIALS

Consult factory for others.

Body/Bonnet: Ductile Iron (epoxy coated), Carbon Steel (epoxy coated), Stainless Steel

Seat Ring: Stainless Steel, Bronze

Stem: Stainless Steel, Monel

Spring: Stainless Steel

Diaphragm: Buna-N, Viton, (Nylon reinforced)

Seat Disc: Buna-N, Viton

Tubing & Fittings: Stainless Steel

SPECIFICATIONS (Typical Aviation Fueling Application)

The tank safety valve shall operate by means of hydraulic pressure from the transfer pump discharge. The valve shall open on positive pressure and close on loss of pressure. It shall be equipped to relieve downstream to upstream in the event of thermal buildup. It shall be equipped with a manual opening feature and valve position indicator.

DESIGN

The tank safety valve shall be a single-seated, dual chamber, diaphragm actuated globe valve. The valve shall seal by means of a corrosion-resistant seat and a resilient, rectangular seat disc. These, and other parts, shall be replaceable without removing the valve from the line. The stem of the main valve shall be guided top and bottom by integral bushings. Alignment of the body, lower chamber and diaphragm assembly shall be by precision dowel pins. The diaphragm shall not be used as a seating surface, nor shall the pistons be used as an operating means. The tank safety valve shall be operationally and hydrostatically tested prior to shipment.

MATERIALS OF CONSTRUCTION

The main valve body and bonnet shall be ductile iron. All ferrous surfaces shall be coated with 4 mils of epoxy. The main valve seat ring shall be stainless steel. Elastomers (diaphragms, resilient seats and O-rings) shall be Buna-N.

ACCEPTABLE PRODUCTS

The tank safety valve shall be a <size> Model 66TS, <globe pattern, angle pattern>, with <150# flanged, 300# flanged, threaded, grooved> end connections, as manufactured by OCV Control Valves, Tulsa, Oklahoma, USA.

DIM	ANSI FLANGE	3"	4"	6"	8"	10"	12"	16"
A	150	12	15	17.75*	25.38	29.75	34.00	40.38
	300	12.75	15.62	18.62*	26.38	31.12	35.50	42.00
B	150	3.75	4.50	5.50	6.75	8.00	9.50	11.75
	300	4.12	5.00	6.25	7.50	8.75	10.25	12.75
C	ALL	10.75	13.50	17.50	20.00	23.00	25.00	32.00
D	ALL	4.38	5.88	7.00	10.50	12.25	14.00	17.25
E	ALL	5.12	6.38	8.62	12.00	14.00	16.00	19.25

*Note: for military fueling valves, 6" 150# flanges have 20" face to face dimensions and 6" 300# flanges have 20-7/8" face to face dimensions.

For maximum efficiency, the OCV control valve should be mounted in a piping system so that the valve bonnet (cover) is in the top position. Other positions are acceptable but may not allow the valve to function to its fullest and safest potential. In particular, please consult the factory before installing 8" and larger valves, or any valves with a limit switch, in positions other than described. Space should be taken into consideration when mounting valves and their pilot systems.

A routine inspection & maintenance program should be established and conducted yearly by a qualified technician. Consult our factory @ **1-888-628-8258** for parts and service.

How to order your Model 66TS valve

When ordering please provide:
 Fluid to be controlled - Model Number - Size - Globe or Angle - End Connection - Body Material - Trim Material - Elastomers - Special Requirements / Installation Requirements

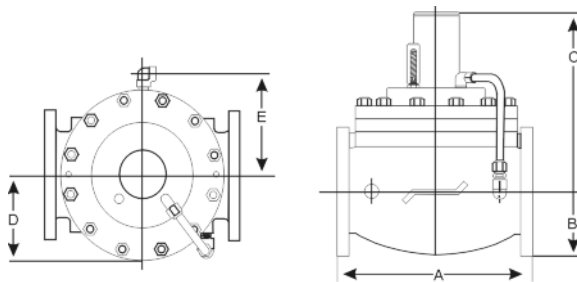

QUALITY SYSTEM
 REGISTERED TO
 ISO 9001

United States/Canada Joint
 Certification Program (JCP)
 Certification Number 0073030

Represented by:

TOLL FREE 1.888.628.8258 • phone: (918)627.1942 • fax: (918)622.8916 • 7400 East 42nd Place, Tulsa, Oklahoma 74145
 email: sales@controlvalves.com • website: www.controlvalves.com