

# pressure sustaining and check valve

## installation, operating, and maintenance instructions

# model 108-3

### GENERAL DESCRIPTION

The OCV Model 108-3, also described as a **back pressure control valve**, performs two primary functions:

1. As a **Pressure Sustaining Valve**. Here the 108-3 is installed in the main line itself. It functions to control the incoming pressure at the set point, or more commonly, to prevent the pressure from falling below a predetermined minimum. For example, it may be installed on the discharge of a pump to ensure that the pump remains "on its curve."
2. **Check Valve**: In the event of pressure reversal, the 108-3 will close and remain closed to prevent reverse flow. Again, installed on the discharge of a pump, it precludes the need for a separate check valve.

The Model 108-3 consists of the following components, arranged as shown on the schematic diagram:

1. **Model 65 Basic Control Valve**, a hydraulically-operated, diaphragm-actuated, globe or angle valve which closes with an elastomer-on-metal seal.
2. **Model 1330 Pressure Relief Pilot**, a two-way, normally-closed pilot valve which senses upstream pressure under its diaphragm and balances it against an adjustable spring load. An increase in upstream pressure tends to make the pilot open.

3. **Model 126 Ejector**, a simple "tee" fitting with a fixed orifice in its inlet port. It provides the proper pressure to the diaphragm chamber of the main valve depending on the position of the pressure relief pilot.
4. **Model 141-3 Flow Control Valve**, a needle-type valve which provides adjustable, restricted flow in one direction, and free flow in the opposite

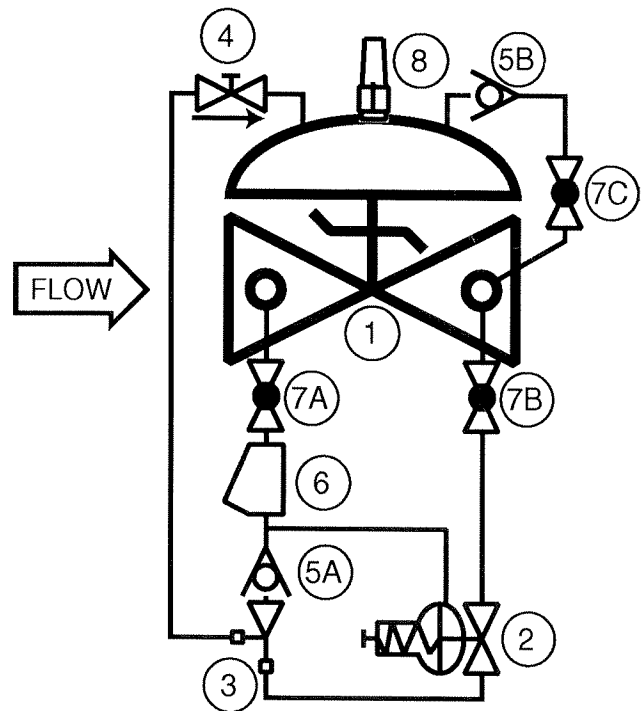

direction. On the 108-3, the flow control valve is connected as a **closing speed control**.

5. Two **Model 141-1 Check Valves**, which enable the 108-3 to function as a check valve.
6. **Model 159 Y-Strainer** (standard on water service valves) or **Model 123 Inline Strainer** (standard on fuel service valves). The strainer protects the pilot system from solid contaminants in the line fluid.
7. Three **Model 141-4 Ball Valves** (standard on water service valves, optional on fuel service valves), useful for isolating the pilot system for maintenance or troubleshooting.

At user option, the 108-3 may also be equipped with the following:

1. Model 155 Visual Indicator.
2. Model 150 Limit Switch Assembly (includes visual indicator).
3. Model 141-3 Opening Speed Control.

### **THEORY OF OPERATION**

**PRESSURE SUSTAINING ACTION:** To understand how the 108-3 operates, it is best to start with the **Ejector (3)**. Due to the orifice in its upstream port, the ejector creates a pressure drop proportional to the flow through it. The flow through the ejector is in turn controlled by the degree of opening of the **Pressure Relief Pilot (2)**. The **wider** the pilot **opens**, the **greater the flow** through the ejector and the **lower the pressure** downstream of the orifice. Conversely, the **more** the pilot **closes**, the **lower the flow** through the ejector and the **greater the pressure** downstream of the orifice.

Now note that the diaphragm chamber of the Main Valve (1) is connected to the branch port of the ejector and is thus downstream of the orifice. Therefore, the pressure in the diaphragm chamber of the main valve is effectively controlled by the pressure relief pilot, in the manner described above. As the pilot **opens**, the diaphragm pressure **decreases** and the main valve **opens**; as the pilot **closes**, the diaphragm pressure **increases** and the main valve **closes**.

Typically, the pressure upstream of the main valve is normally above the set point of the relief pilot. Therefore, the pilot is wide open as is the main valve. However, if system demand increases to the point that the upstream pressure tries to fall below the set point, the pilot will start to close and the main valve will follow, throttling as required to keep the pressure from falling any further.

**CHECK ACTION:** If the pressure differential across the valve should reverse itself—for example, if the pump stops, the now-higher downstream pressure will open **check valve (5B)**, build up on the diaphragm and cause the main valve to close quickly and tightly. At the same time, **check valve (5A)** will close, preventing any reverse flow through the pilot system.

### **INSTALLATION**

Figure 1 shows a typical installation of a 108-3 on the discharge of a centrifugal pump. Here it will keep a minimum back pressure on the pump to keep it from running off the right side of its curve in periods of high system demand. It will also act as the pump discharge check valve. This illustration is intended only as rough guides for valve installation, as indeed there are many other places in a system where the 108-3 can be effectively employed. Notice, however, the use of isolation valves. While these do not affect the operation of the 108-3, they can be extremely useful if the valve needs to be isolated from the line for maintenance or repair.

For full installation details, the user is referred to the Model 65 Basic Valve section of this manual.

### **START-UP AND ADJUSTMENTS**

The following procedures should be followed in the order presented in order to affect an initial startup of the 108-3.

1. Install a pressure gauge of the proper range upstream of the 108-3. The unused **inlet** side port in the main valve body may be used for this purpose if there is no convenient location in the upstream piping.
2. Remove the plastic cap from the pressure relief pilot (2) and loosen the adjusting screw jam nut. Turn the adjusting screw **clockwise** to a full stop.

3. Loosen the adjusting screw jam nut on the flow control valve (4) (closing speed control). Turn the adjusting screw **clockwise** to a full stop, then **counterclockwise** three full turns.
4. Make sure all threepilot system isolation ball valves (7A-7C) are **open**.
5. Start the pump or otherwise start the system flowing. The main valve at this time should be fully closed.
6. Carefully loosen a pipe plug in the main valve bonnet until fluid begins to discharge around the threads. When only clear fluid (no air) is discharging, retighten the plug.
7. Turn the adjusting screw of the pressure relief pilot (2) counterclockwise until it is loose enough to be turned with the fingers. The main valve should open fully.
8. Observing the inlet pressure gauge, open valves or otherwise increase flow until the pressure falls to a point approximately 5 psi below the desired set point.
9. Slowly turn the adjusting screw of the pressure relief pilot (2) **clockwise** until the pressure rises to **the set point**. Tighten the adjusting screw jam nut and replace the plastic cap.
10. Shut down the pump.

## MAINTENANCE

Because of the simplicity of design of the 108-3, required maintenance is minimal. However, the following checks, periodically performed, can do much to keep the valve operating properly and efficiently.

1. Check for chipped or peeling paint. Touch up as required.
2. Check for leaks at fittings and around flanges and connections. Tighten as required.
3. If the valve is equipped with a Y-strainer, check the screen for buildup of solid material. Clean as required. This point is most important, as a clogged strainer can keep the valve from closing. On new installations, it is recommended that the

strainer be checked every day or two until experience dictates a greater or lesser interval. Strainer maintenance is covered in detail on a special page later in this manual.

## TROUBLESHOOTING

In the event of malfunction of the 108-3, the following guide should enable the technician to isolate the specific cause of the problem and take the appropriate corrective action.

### A. MAIN VALVE FAILS TO OPEN:

1. Valve closed upstream or downstream of the 108-3. Open as required.
2. Downstream pilot system ball valve (7B) closed. Open as required.
3. Pressure relief pilot (2) adjusted too far clockwise. See Adjustment instructions.
4. Diaphragm of pressure relief pilot (2) ruptured. This will be evidenced by a discharge of fluid from the vent hole in the pilot bonnet. Replace diaphragm. See the 1330 Pilot section of this manual.
5. Stem of pressure relief pilot (2) binding. Disassemble pilot and determine cause. See the 1330 Pilot section of this manual.
6. Stem of main valve binding. Disassemble valve and determine cause. See the Model 65 Basic Valve section of this manual.

### B. MAIN VALVE FAILS TO CLOSE:

1. Upstream pilot system ball valve (7A) closed. Open as required.
2. Strainer (6) clogged. Clean as required.
3. Closing speed control adjusted fully closed. Open as required. See Adjustment instructions.
4. Check valve (5A) clogged or stuck closed. Repair or replace as required.
5. Pressure relief pilot (2) adjusted too far counterclockwise. See Adjustment instructions.

6. Close pilot system ball valve (7C).
  - (a) If valve closes, check valve (5B) is leaking badly or stuck open. Repair or replace as required.
  - (b) If valve remains open, proceed to Step 7.
7. Close the downstream pilot system ball valve (7B).
  - (a) If valve closes, proceed to Step 8.
  - (b) If valve remains open, proceed to Step 9.
8. Pressure relief pilot (2) stem binding or seat badly deteriorated. Disassemble pilot and determine cause. See the 1330 Pilot section of this manual.
9. Close all three pilot system ball valves (7A-7C) and loosen a pipe plug in the main valve bonnet. A **continuous** discharge of fluid from the loosened plug indicates that the main valve diaphragm is ruptured. Replace diaphragm. See the Model 65 Basic valve section of this manual.

**NOTE:** Certain valves, predominantly those in fuel service, are assembled "fail closed." In this case, a ruptured diaphragm would keep the valve from opening, rather than keep it from closing. To determine which type you have, examine the "bridge mark" cast into the side of the main valve body and compare it with the diagram below.

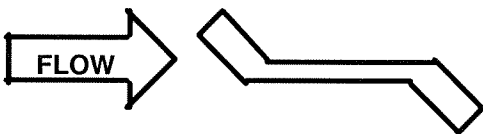

FLOW UNDER SEAT

DIAPHRAGM FAILURE = VALVE FAILS TO CLOSE

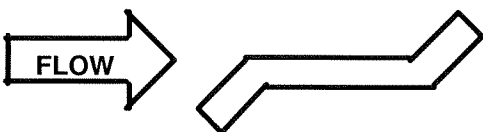

FLOW OVER SEAT

DIAPHRAGM FAILURE = VALVE FAILS TO OPEN

**C. VALVE WILL NOT CHECK**

1. Pilot system ball valve (7C) closed. Open as required.
2. Close pilot system ball valve (7A).
  - (a) If backflow stops, check valve 5A is leaking or stuck open. Repair or replace as necessary.
  - (b) If backflow continues, proceed to Step 3.
3. Check valve (5B) stuck closed. Repair or replace as necessary.
4. Damaged seat or object caught in main valve. Disassemble valve and determine cause. See the model 65 Basic Valve section of this manual.

10. Main valve stem binding or object caught in valve. Disassemble valve and determine cause. See the Model 65 Basic Valve section of this manual.

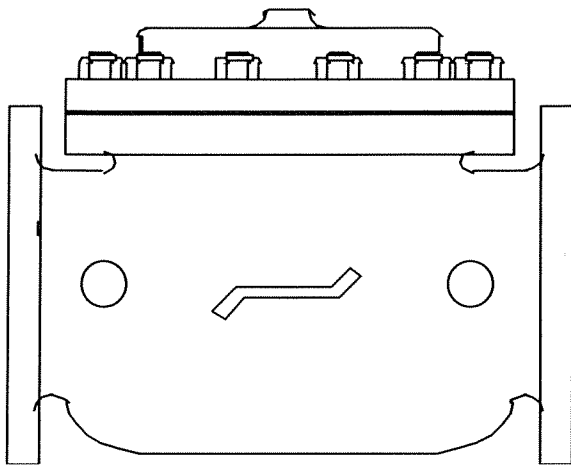

## installation, operating, and maintenance instructions

# series 65

## basic control valve

### GENERAL DESCRIPTION

The OCV Series 65 is a hydraulically-operated, diaphragm-actuated valve. It is available in either a globe (Model 65) or angle (Model 65A) configuration. The diaphragm is nylon-fabric bonded with synthetic rubber and forms a sealed chamber in the upper portion of the valve, separating operating pressure from line pressure. An elastomeric seat disc forms a tight seal with the valve seat when pressure is applied above the diaphragm.

### FUNCTIONAL DESCRIPTION

Because the Series 65 is a hydraulically operated valve, it requires a minimum line pressure of approximately 5 psig in order to function. The valve functions on a simple principle of pressure differential. The line pressure at the inlet of the valve is bypassed through the pilot control piping to the diaphragm chamber of the valve. This pressure, together with the valve spring, works against the pressure under the valve seat. Because the effective area of the diaphragm is greater than that of the seat, the valve is held tightly closed. As the controlling pilot(s) allow the pressure to bleed off the diaphragm chamber, the two opposing pressures begin to balance and the valve will begin to open. The valve can be used to perform a simple on-off function, or with the proper pilot system, a modulating, or regulating function.

In cases where the line fluid is unusually dirty, or is otherwise unsuitable for operating the valve, an independent operating pressure source may be employed. The pressure available from such a source must be equal to, or greater than, line pressure.

### INSTALLATION

In order to insure safe, accurate and efficient operation of the OCV control valve, the following list of checkpoints and procedures should be followed when installing the

valve.

1. Make a careful visual inspection of the valve to insure that there has been no damage to the external piping, fittings or controls. Check that all fittings are tight.
2. Thoroughly flush all interconnecting piping of chips, scale and foreign matter prior to mounting the valve.
3. Install the valve in the line according to the flow arrow on the inlet flange. The arrow should point downstream.
4. Allow sufficient room around the valve for ease of adjustment and maintenance service.

In addition, it is highly recommended that:

1. Isolation valves (eg., gate or butterfly) be installed on the inlet and discharge sides of the valve to facilitate isolating the valve for maintenance.
2. Pressure gauges be installed at the inlet and outlet sides of the valve to provide monitoring of the valve during initial start-up and during operation. The body side ports, if unused by the pilot system, provide a convenient connection for the gauges.
3. All valves larger than 6" be installed horizontally, i.e., with the bonnet pointed up, for ease of adjustment and maintenance servicing.

### MAINTENANCE

The OCV control valve requires no lubrication and a minimum of maintenance. However, a periodic inspection should be established to determine how the fluid being handled is affecting the efficiency of the valve. In a water system, for example, the fluid velocity as well as the substances occurring in natural waters, such as dissolved minerals and suspended particles, vary in every installation. The effect of these actions or substances must be determined by inspection. It is recommended that an annual inspection, which includes ex-

amination of the valve interior, be conducted. Particular attention should be paid to the elastomeric parts, i.e., the diaphragm and seat disc. Any obviously worn parts should be replaced.

### REPAIR PROCEDURES

In the event of malfunction of the OCV control valve, troubleshooting should be conducted according to the procedures outlined for the specific model of valve. Then, if those steps indicate a problem with the main valve, this section will outline the procedures necessary to correct the problem.

Problems with the main valve can be classed in three basic categories:

1. VALVE FAILS TO OPEN
  - a. Diaphragm damaged\* - See Procedure A
  - b. Stem binding - See Procedure B
2. VALVE FAILS TO CLOSE
  - a. Diaphragm damaged\* - See Procedure A
  - b. Stem binding - See Procedure B
  - c. Object lodged in valve - See Procedure B
3. VALVE OPENS AND CLOSES BUT LEAKS WHEN CLOSED
  - a. Seat disc damaged - See Procedure C
  - b. Seat ring damaged - See Procedure D

\*A diaphragm failure can prevent the valve from either opening or closing, depending on the flow direction. Most water service valves flow "under the seat", in which case a diaphragm failure will keep the valve from closing. On the other hand, most fuel service valves flow "over the seat", in which case a diaphragm failure will keep the valve from opening. To determine which you have, examine the bridge mark cast into the side of the valve body, then compare it with the figures below.

#### PROCEDURE A : DIAPHRAGM REPLACEMENT

1. Isolate the valve from the system by closing upstream and downstream block valves.
2. Loosen one of the tubing connections on the bonnet. Allow any residual pressure to bleed off.
3. Remove all tubing connected at the bonnet.
4. Remove the bonnet nuts.
5. Remove the bonnet. If the bonnet sticks in place, it may be loosened by rapping sharply around its edge with a rubber-headed mallet. *NOTE: 8" and larger valves are equipped with eye bolts through which a chain can be fastened to aid in*

*lifting the bonnet.*

6. Remove the spring.
7. Remove the diaphragm plate capscrews and the diaphragm plate.
8. Remove the old diaphragm.
9. Making sure the dowel pin holes are in the proper location, place the new diaphragm over the studs and press down until it is flat against the body and spool.
10. Replace the diaphragm plate and the diaphragm plate capscrews.
11. Tighten all diaphragm plate capscrews snugly.
12. Replace the spring.
13. Replace the bonnet and reinstall the bonnet nuts.
14. Tighten the bonnet nuts snugly using a criss-cross tightening pattern.
15. Reinstall the control tubing.
16. Reopen the upstream and downstream block valves.
17. Before placing the valve back in service, perform the air bleed procedure described in the first section of this manual.

#### PROCEDURE B: CORRECTION OF BINDING STEM

1. Perform Steps 1 thru 6 of Procedure A, above.
2. Remove the spool assembly from the valve. *NOTE:*

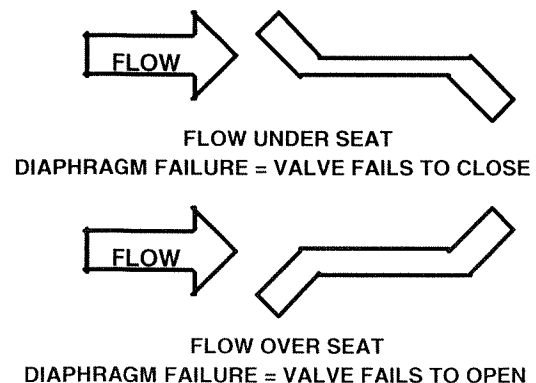

*On smaller valves, this can be accomplished simply by grasping the stem and pulling upward. Valves 6" and larger have the top of the stem threaded to accept an eyebolt to aid in lifting the spool out of the body. 6" thru 12" valves are threaded 3/8-16. 14" and 16" valves are threaded 5/8-11.*

3. Carefully examine both ends of the stem for deep scratches, scoring or buildup of mineral deposits.

- Polish the stem if necessary using a fine grade of emery cloth.
- 4. Similarly, examine and polish the upper bushing (in the bonnet) and the lower guide (in the seat ring).
- 5. Reinstall the spool assembly.
- 6. Reassemble the valve, following Steps 12 thru 17 in Procedure A.

**PROCEDURE C: SEAT DISC REPLACEMENT**

- 1. Perform Steps 1 and 2 of Procedure B, above.
- 2. With the spool assembly removed from the body, remove the seat retainer screws.
- 3. Slide the seat retainer off the lower end of the stem.
- 4. Remove the seat disc from its groove in the spool.  
*NOTE: The seat disc may fit quite tightly in the groove. If necessary, it may be pried out using a thin-bladed screwdriver or similar tool.*
- 5. Install the new seat disc in the groove.
- 6. Reinstall the seat retainer and tighten the seat retainer screws.
- 7. Reassemble the valve, following Steps 5 and 6 of Procedure B.

**PROCEDURE D: SEAT RING REPLACEMENT**

*NOTE: It is rare for a seat ring to require replacement. Minor nicks and scratches in the seating surface can usually be smoothed out with emery cloth.*

- 1. Perform Steps 1 and 2 of Procedure B, above.
- 2. If you are working on a 4" or smaller valve, follow Steps 3 thru 9, below.
- 3. If you are working on a 6" or larger valve, follow Steps 10 thru 16, below.

- 4. Seat rings in valves 4" and smaller are threaded into the valve body. To remove, you will need a special seat ring tool. You may fabricate one using standard pipe as shown in the sketch below, or one may be purchased from OCV.
- 5. Using the seat ring tool, unthread the seat ring from the body.
- 6. Remove the old o-ring from the counterbore in the body.
- 7. Install the new o-ring in the counterbore.
- 8. Using the seat ring tool, install the new seat ring.
- 9. Reassemble the valve, following Steps 5 & 6 of Procedure B.
- 10. Seat rings in valves 6" and larger are bolted into the body with socket head capscrews. In addition you will note that the seat ring is equipped with additional threaded holes that may be used for "jacking" the seat ring out of the body.
- 11. Remove the socket head capscrews.
- 12. Remove the old seat ring from the body by temporarily installing two or more of the capscrews in the "jacking" holes.
- 13. Install a new o-ring in the groove of the new seat ring. Lubricate the o-ring and outer seat ring wall with Vaseline® or similar lubricant.
- 14. Install the new seat ring in the body, making sure that the capscrew holes line up.
- 15. Replace and tighten all the capscrews.
- 16. Reassemble the valve, following Steps 5 and 6 of Procedure B.

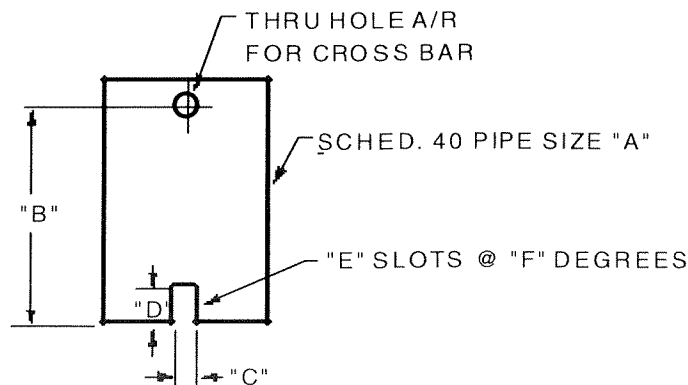

VALVE SIZE	"A" PIPE SIZE	"B" MIN. LENGTH	"C" SLOT WIDTH	"D" SLOT DEPTH	"E" NO. OF SLOTS	"F" SLOT SPACING
1-1/4"	3/4"	6"	3/8"	3/8"	2	180°
1-1/2"	3/4"	6"	3/8"	3/8"	2	180°
2"	1-1/2"	7"	3/8"	3/8"	2	180°
2-1/2"	2"	8"	1/2"	1/2"	3	120°
3"	2-1/2"	9"	5/8"	5/8"	2	180°
4"	3"	10"	5/8"	5/8"	2	180°

REVISED 3-17-97

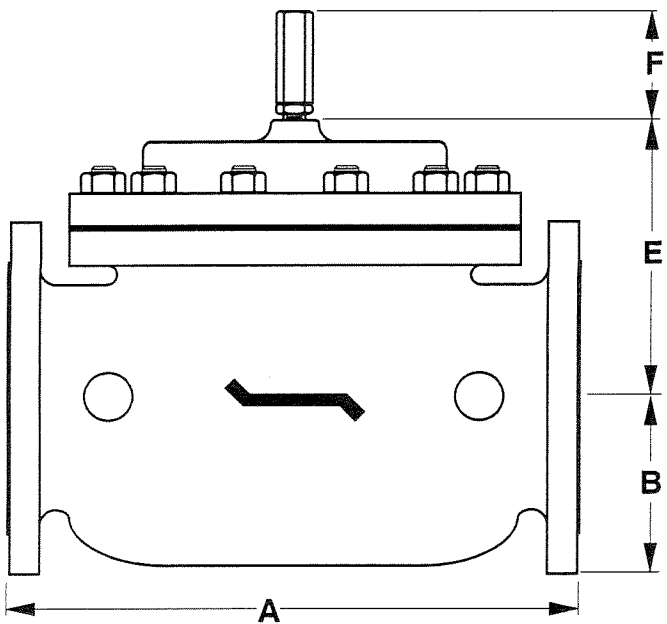
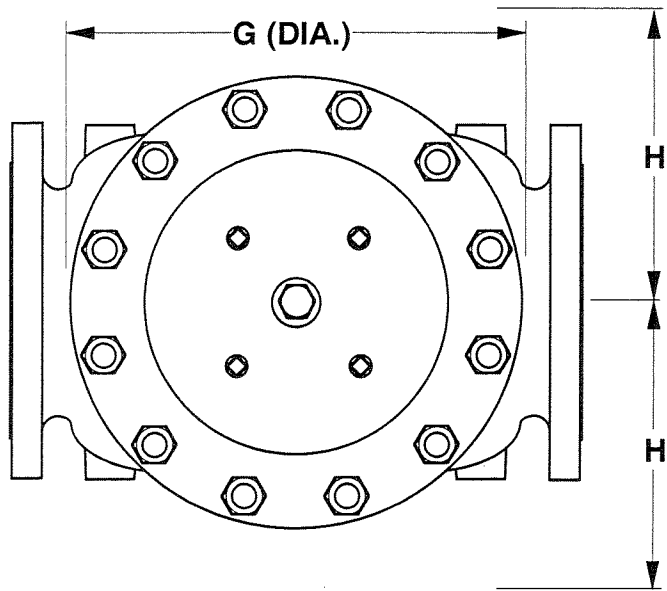

DIM	ANSI CLASS	VALVE SIZE													
		1 1/4	1 1/2	2	2 1/2	3	4	6	8	10	12	14	16	24	
A	SE	8.75	8.75	9.88	10.50	13.00	-	-	-	-	-	-	-	-	
	150	8.50	8.50	9.38	10.50	12.00	15.00	17.75	25.38	29.75	34.00	39.00	40.38	62.00	
	300	8.75	8.75	9.88	11.12	12.75	15.62	18.62	26.38	31.12	35.50	40.50	42.00	63.75	
B	SE	1.44	1.44	1.69	1.88	2.25	-	-	-	-	-	-	-	-	
	150	2.31	2.50	3.00	3.50	3.75	4.50	5.50	6.75	8.00	9.50	10.62	11.75	16.00	
	300	2.62	3.06	3.25	3.75	4.12	5.00	6.25	7.50	8.75	10.25	11.50	12.75	18.00	
C	SE	4.38	4.38	4.75	6.00	6.50	-	-	-	-	-	-	-	-	
	150	4.25	4.25	4.75	6.00	6.00	7.50	10.00	12.69	14.88	17.00	-	20.81	-	
	300	4 3/8	4.38	5.00	6.38	6.38	7.81	10.50	13.19	15.56	17.75	-	21.62	-	
D	SE	3.12	3.12	3.88	4.00	4.50	-	-	-	-	-	-	-	-	
	150	3.00	3.00	3.88	4.00	4.00	5.50	6.00	8.00	11.38	11.00	-	15.69	-	
	300	3.25	3.25	4.12	4.38	4.38	5.81	6.50	8.50	12.06	11.75	-	16.50	-	
E	ALL	6.00	6.00	6.00	7.00	6.50	7.92	10.00	11.88	15.38	17.00	18.00	19.00	27.00	
F	ALL	3.88	3.88	3.88	3.88	3.88	3.88	3.88	6.38	6.38	6.38	6.38	6.38	8.00	
G	ALL	6.00	6.00	6.75	7.69	8.75	11.75	14.00	21.00	24.50	28.00	31.25	34.50	52.00	
H	ALL	10.00	10.00	11.00	11.00	11.00	12.00	13.00	14.00	17.00	18.00	20.00	20.00	28.50	

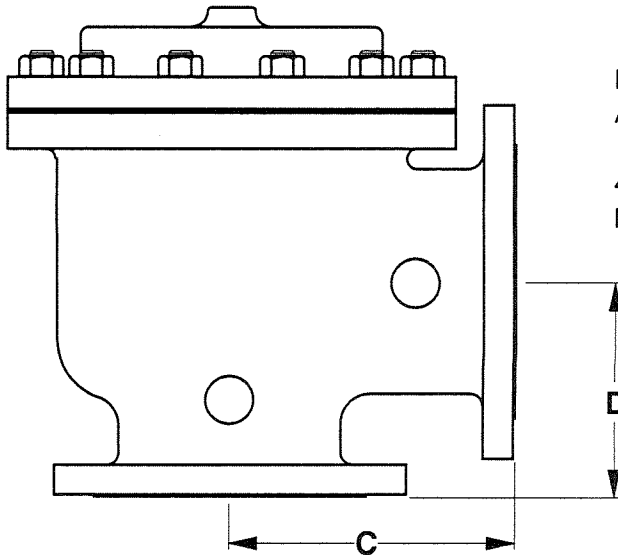

NOTE: 3" VALVE DIMENSIONS ARE FOR NEW MODEL 3100

4" VALVE DIMENSIONS ARE FOR NEW MODEL 4400

REV. A SDJ 6-6-02  
REV. B SDJ 2-3-03

<b>TOLERANCES</b>		 <b>OCV Control Valves</b> TULSA, OKLAHOMA U.S.A.	
UNLESS NOTED FRACTIONAL $\pm 1/64$ DECIMAL $\pm .005$ MACH. FINISH $125/\sqrt{\quad}$ ANGULAR $\pm 1/2^\circ$			
<b>GENERAL VALVE DIMENSIONS</b>			
DRAWN BY SDJ	DATE 10-6-97	SIZE <b>A</b>	DRAWING NUMBER <b>65D</b>
CHKD. BY	DATE		REV. <b>B</b>



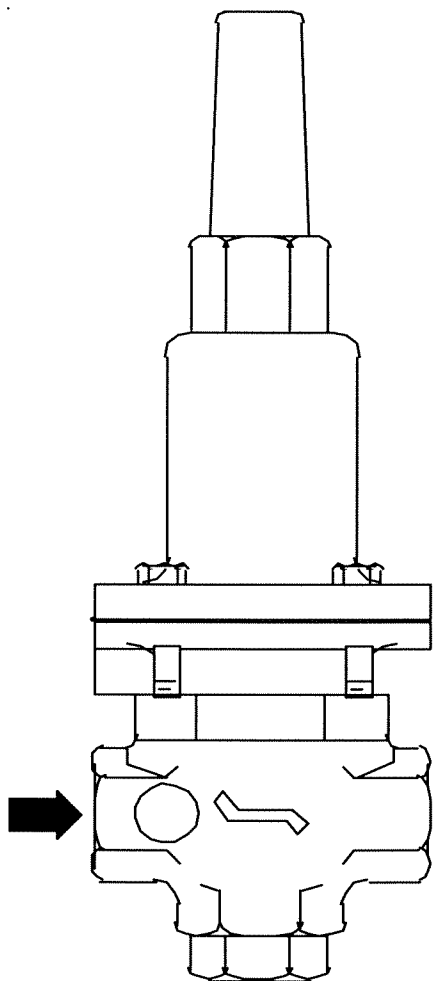

## installation, operating, and maintenance instructions

### pressure sustaining/ pressure relief pilot

**model 1330**

#### **GENERAL DESCRIPTION**

The Model 1330 Pressure Sustaining/Pressure Relief Pilot is a normally-closed, direct-acting, spring-loaded, diaphragm-type control pilot. As the primary control pilot for the OCV Series 108 control valves, it is designed to maintain a constant preset inlet pressure on the main valve. It is a constant throttling device, maintaining precise, positive control of the main valve. The 1330 may also be used by itself as a back pressure regulator.

The 1330 is available in bronze or stainless steel construction and with 3/8 NPT or 1/2 NPT end connections.

The 1330 is available with four different adjustment ranges:

5-30 psi	65-180 psi
20-80 psi	100-300 psi

#### **FUNCTIONAL DESCRIPTION**

The 1330 controls the pressure in the diaphragm cham-

ber of the main valve, hence the degree of opening or closing of the valve. The upstream pressure is sensed under the diaphragm of the pilot and is balanced against an adjustable spring load. As the upstream pressure increases above the set point, the pilot opens wider, decreasing the pressure in the diaphragm chamber of the main valve, opening the valve a proportionate amount. Conversely, as upstream pressure decreases below the set point, the pilot closes further, increasing the pressure in the diaphragm chamber of the main valve, closing the valve a proportionate amount. The net result is a constant modulating action of the pilot and main valve, keeping the upstream pressure at the set point within very close limits.

#### **INSTALLATION AND ADJUSTMENT**

The 1330 is normally installed in the main valve control piping between the ejector and the downstream body tap. Flow must be in the direction indicated. A sensing line, typically 1/4" O.D. tubing, must be installed between the pilot sense port and the upstream

control piping ahead of the ejector.

Pressure adjustment is made by means of the single adjusting screw:

**Clockwise** adjustment **increases** upstream pressure.

**Counterclockwise** adjustment **decreases** upstream pressure.

## MAINTENANCE

Required maintenance of the 1330 is minimal. Fittings and bolts should be periodically checked, and the body should be inspected for damage or excessive buildup of foreign material.

## TROUBLESHOOTING

Other than improper adjustment, there are basically only three malfunctions which can occur with the 1330 pilot. These, and the symptoms they can cause, are as follows:

1. **PILOT DIAPHRAGM RUPTURED:** Results in failure of the main valve to open. A ruptured pilot diaphragm will be evidenced by leakage through the vent hole in the pilot bonnet.
2. **PILOT SEAT DISC DETERIORATED:** Results in failure of the valve to seal off completely (pressure relief service). Can also cause poor pressure control.
3. **PILOT STEM BINDING:** Typically results in poor pressure control, though in extreme cases, it can result in failure of the main valve to open or close.

## REPAIR PROCEDURES

Refer to the 1330 assembly drawing for parts identification.

### A. DIAPHRAGM REPLACEMENT

1. Prior to disassembling the pilot, turn the adjusting screw (10) fully counterclockwise until it is loose enough to be turned with the fingers.
2. Remove the four bonnet capscrews (17).
3. Remove the bonnet (2). Set the spring (9) and spring retainers (11) aside in a safe place.
4. Pull the adapter (3) out of the pilot body (1).

5. Remove hex nut (16), lockwasher (22), upper diaphragm plate (8) and o'ring (20).
6. Remove old diaphragm (5).
7. Inspect both diaphragm plate o'rings (20). Replace if necessary.
8. Place new diaphragm on stem (7).
9. Replace upper diaphragm plate (8), o'ring (20), lockwasher (22) and hex nut (16). Tighten securely.
10. Insert adapter (2) back into pilot body (1).
11. Hold spring (9) and spring retainers (11) together in the proper orientation and insert them into the bonnet (2).
12. Place the bonnet over the adapter and insert the bonnet capscrews (17). Tighten securely.
13. Place valve back in service, following the startup and adjustment procedures given in the main portion of this manual.

### B. SEAT DISC REPLACEMENT

1. Follow Steps 1 through 4 under DIAPHRAGM REPLACEMENT, above.
2. Remove capscrew (12), seal washer (13) and old seat disc (6).
3. Place new seat disc, new seal washer and capscrew (12) on stem. Tighten securely.
4. Reassemble pilot following Steps 10 through 13 under DIAPHRAGM REPLACEMENT, above.

### C. STEM REPAIR

1. Follow Steps 1 and 2 under SEAT DISC REPLACEMENT, above.
2. Remove stem (7) from adapter (3).
3. Inspect stem and o'ring (21) carefully.
4. Remove any foreign material or light scratches from the stem with a fine grade of emery cloth. A badly scored stem should be replaced.
5. Replace o'ring (21).
6. Lubricate the o'ring and stem liberally with Vaseline® or similar lubricant.
7. Place stem in adapter (3). Make sure it moves freely.
8. Reassemble pilot following Steps 3 and 4 under SEAT DISC REPLACEMENT, above.

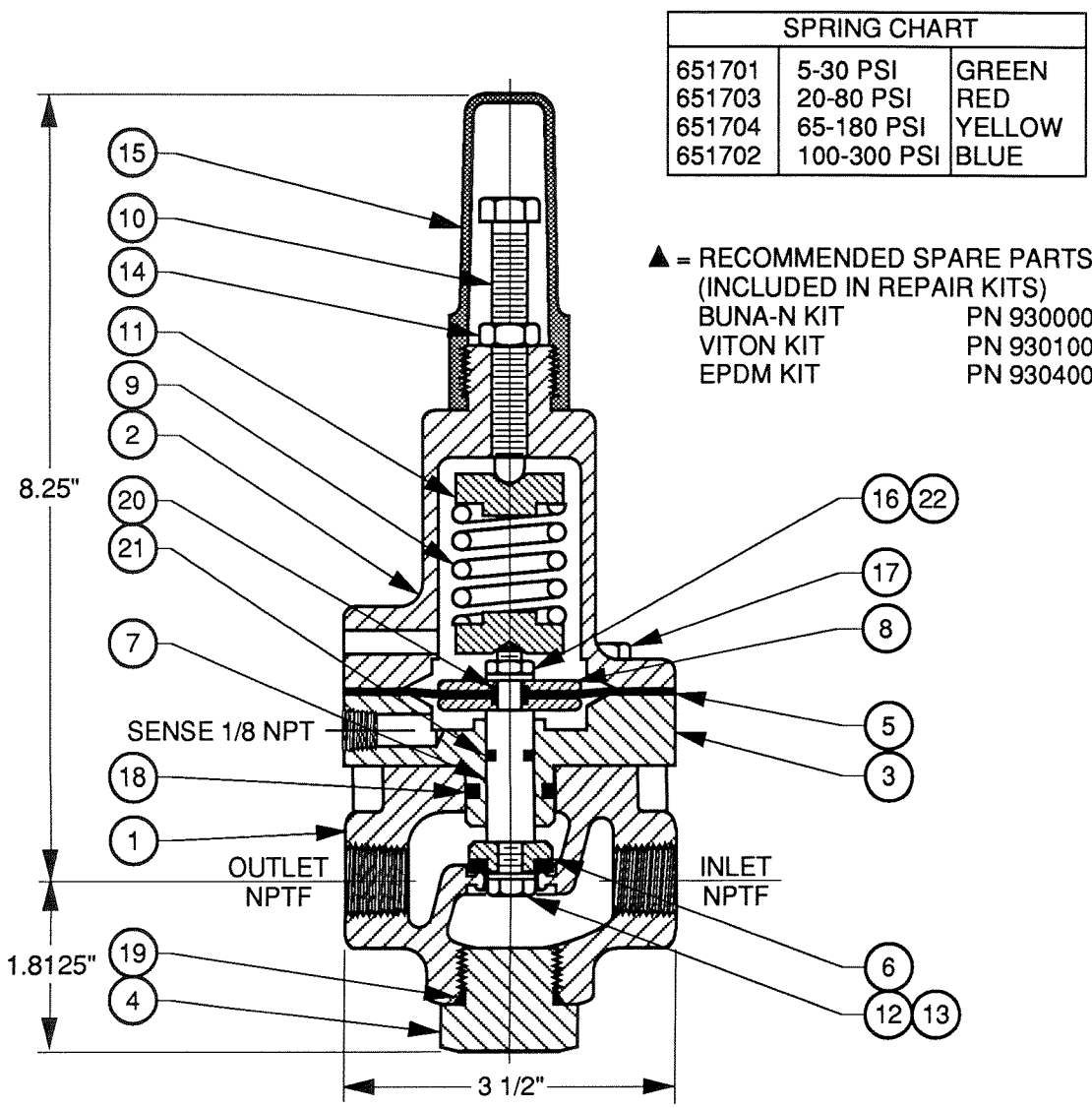

SPRING CHART		
651701	5-30 PSI	GREEN
651703	20-80 PSI	RED
651704	65-180 PSI	YELLOW
651702	100-300 PSI	BLUE

▲ = RECOMMENDED SPARE PARTS  
(INCLUDED IN REPAIR KITS)

BUNA-N KIT PN 930000  
 VITON KIT PN 930100  
 EPDM KIT PN 930400

ITEM	PART NO	QTY	DESCRIPTION	MATERIAL
1	302102	1	BODY	3/8" NPTF
	302104			1/2" NPTF
	302702			3/8" NPTF
	302704			1/2" NPTF
2	304102	1	BONNET	BRONZE
	304702			STN STEEL
3	300129	1	ADAPTOR	BRONZE
	300719			STN STEEL
4	692502	1	PLUG	ZINC PLTD STL
	310730			STN STEEL
5	694002	1	DIAPHRAGM	BUNA-N / NYLON
	694102			VITON / NYLON
	694016			EPDM / NYLON
6	310703	1	SEAT DISC	BUNA-N / SS
	310709			VITON / SS
	310707			EPDM / SS
7	314702	1	STEM	STN STEEL
	314002			MONEL
8	308102	2	DIAPHRAGM PLATE	BRASS
	308702			STN STEEL
	308702			STN STEEL
9	CHART	1	SPRING	STN STEEL
10	300700	1	ADJUSTING SCREW	STN STEEL
11	300134	2	SPRING RETAINER	BRASS
	300729			STN STEEL
12	531700	1	HEX HEAD CAPSCREW	STN STEEL
13	685760	1	LOCKWASHER	STN STEEL
14	590717	1	HEX NUT	STN STEEL
15	692002	1	CAP	PVC
16	590712	1	HEX NUT	STN STEEL
17	531701	4	HEX HEAD CAPSCREW	STN STEEL
18	611116	1	O-RING	VITON
	614116			EPDM
19	610912	1	O-RING	BUNA-N
	611912			VITON
	914912			EPDM
20	611010	2	O-RING	VITON
	614010			EPDM
21	611012	1	O-RING	VITON
	614012			EPDM
22	685700	1	LOCKWASHER	STN STEEL

CHG	E.C. NO.	DATE	BY	REVISIONS

MATERIAL	TOLERANCES
NOTED	UNLESS NOTED FRACTIONAL ±1/64 DECIMAL ±.005 MACH. FINISH 125/ ANGULAR ±1/2°
NO. REQ'D	DRAWN BY RON
	DATE 2-14-96
SCALE 1/2	CHKD. BY 
	DATE 

**OCV Control Valves** TULSA, OKLAHOMA U.S.A.

**MODEL 1330 PILOT 3/8"-1/2" NPTF**  
**PRESSURE RELIEF / SUSTAINING / SURGE**

SIZE <b>A</b>	DRAWING NUMBER <b>1330</b>	REV. 
------------------	-------------------------------	----------

**DESCRIPTION**



**MODEL 126 EJECTOR**  
 The Model 126 ejector is a simple tee fitting with a fixed orifice in its inlet port. It provides the proper supply pressure to the main valve diaphragm chamber, allowing various two-way control pilots to control the valve position.

**MODEL 126 EJECTOR DIAGRAM**

Brass Construction / Stainless Steel Construction

MATERIAL	PART NUMBER	P (NPT)	T-TUBE O.D.	STD. ORIFICE	USED ON VALVE SIZES
Brass	213100	3/8"	3/8"	.125"	1 1/4"-6"
Brass	214100	1/2"	1/2"	.188"	8"-10"
Brass	215100	3/4"	3/4"	.188"	12"-16"
316 Stn. Steel	213700	1/4"	3/8"	.090"	1 1/4"-6"
316 Stn. Steel	214700	3/8"	1/2"	.125"	8"-10"
316 Stn. Steel	215700	1/2"	3/4"	.188"	12"-16"

Orifice bushings are stainless steel.

**STAINLESS**

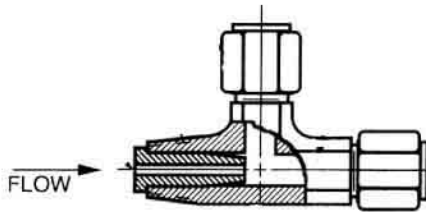

**BRASS**

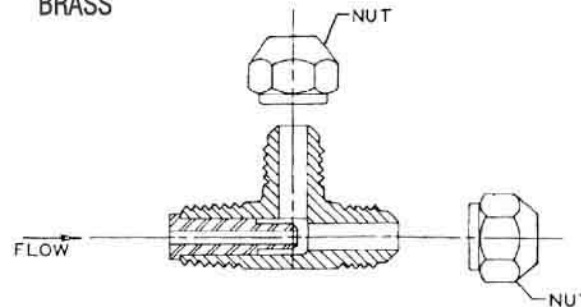

**SCHEMATIC SYMBOL**

The Model 126 Ejector is shown on OCV Valve Schematics as:

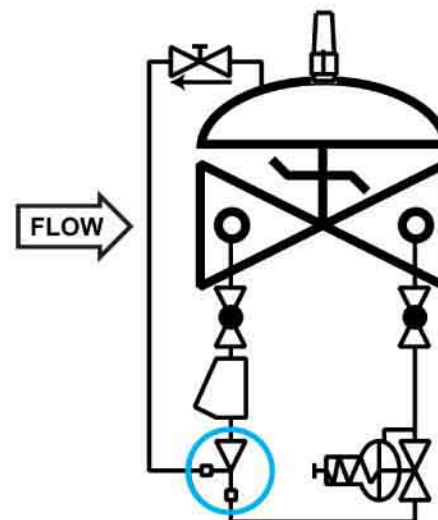
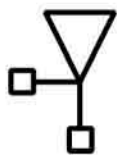

EXAMPLE: Shown here on a MODEL 127-3 Pressure Reducing Valve

**DESCRIPTION**



The Model 141-3 Flow Control Valve is an adjustable restriction device, installed in the control circuit tubing. The flow control valve differs from a standard needle valve in that it includes an internal check valve. Thus it allows free flow in one direction (through the check) and restricted flow in the other direction (through the needle). The setting of the flow control valve meters the flow into or out of the main valve diaphragm chamber,

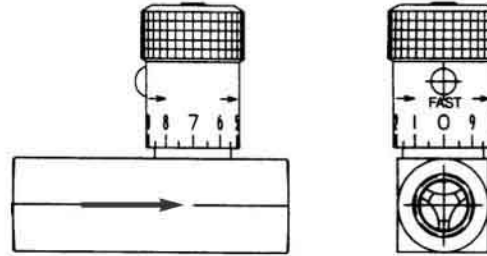

thus controlling either the opening or closing speed of the main valve. These can be installed in series for separate opening and closing speed control. Restricted flow is in the direction of the flow arrow on the body.

**MODEL 141-3 MATRIX**

MATERIAL	PART NUMBER	INLET/OUTLET (NPT)	A	USED ON VALVE SIZE*
Brass	682100	1/4	2 3/8	1 1/4"-2"
Brass	682101	3/8	2 3/4	2 1/2"-6"
Brass	682102	1/2	3 1/4	8"-10"
Brass	682103	3/4	3 7/8	12"-16"
Stn. Steel	682700	1/4	2 3/8	1 1/4"-2" Stn.
Stn. Steel	682701	3/8	2 3/4	2 1/2"-6"
Stn. Steel	682702	1/2	3 1/4	8"-10"
Stn. Steel	682703	3/4	3 5/8	12"-16"

Note: Flow control valve use and size may vary on valve application. Consult factory.

**SCHEMATIC SYMBOL**

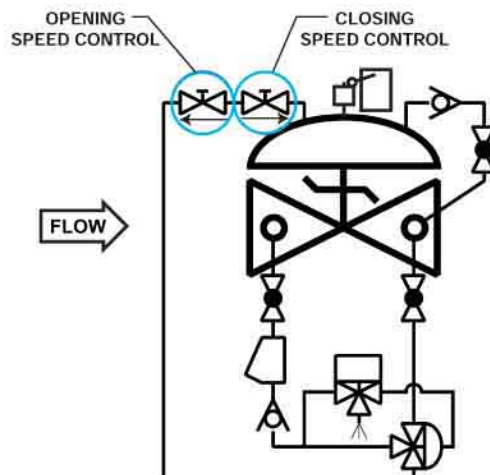

The Model 141-3 Flow Control Valve is shown on OCV Valve Schematics as:

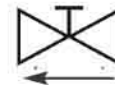

EXAMPLE: Shown here on a MODEL 125 Pump Control Valve as separate opening and closing speeds.

**Flow Control Valves 141-3**

**DESCRIPTION**

The Model 141-1 Check Valve uses a spring-loaded poppet that will allow flow in one direction only. It is the primary component used on valves with a reverse flow check function. Flow is in the direction of the arrow on the check valve body.



◀ Check Valves shown  
Stainless Steel & Brass

**MODEL  
141-1  
MATRIX**

MATERIAL	PART NUMBER	INLET/OUTLET (NPT)	LENGTH	USED ON VALVE SIZE
Bronze	681100	3/8	2	1 1/4"-6"
Bronze	681101	1/2	2 1/8	8"-10"
Bronze	681102	3/4	2 1/4	12"-16"
Stn. Steel	681700	3/8	2 5/16	1 1/4"-6"
Stn. Steel	681701	1/2	2 5/16	8"-10"
Stn. Steel	681702	3/4	2 7/8	12"-16"

**SCHEMATIC  
SYMBOL**

The Model 141-1 Check Valve is shown on OCV Valve Schematics as:

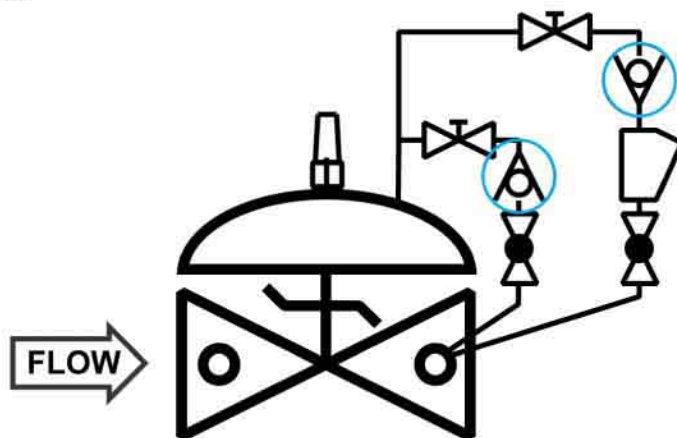
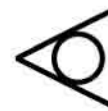

EXAMPLE: Shown here on a  
MODEL 94-3 Check Valve.

**Check Valve 141-1**



**DESCRIPTION**

**MODEL 159 Y-STRAINER**

The 159 Y-Strainer installs in the inlet piping of the pilot system and protects the pilot system from solid contaminants in the line fluid. It is the standard strainer for water service valves.

**MODEL 159 Y-STRAINER MATRIX**

MATERIAL	PART NUMBER	INLET/OUTLET (NPT)	BLOW OFF PORT (NP)	A	STD. MESH	USED ON VALVE SIZE
Bronze	660100	3/8	3/8	2 11/16	24	1 1/4"-6"
Bronze	660101	1/2	3/8	2 5/8	24	8"-10"
Bronze	660102	3/4	3/8	3 5/16	24	12"-16"
Stn. Steel	660700	3/8	1/4	2 1/2	20	1 1/4"-6"
Stn. Steel	660701	1/2	1/4	2 1/2	20	8"-10"
Stn. Steel	660702	3/4	1/4	3 1/8	20	12"-16"

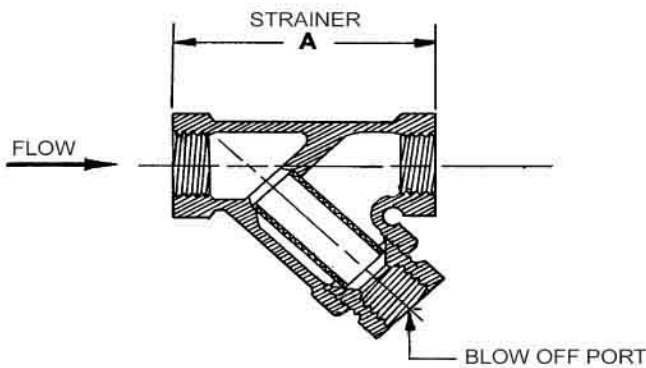

**MATERIALS**

Bronze, ASTM B62  
Optional mesh sizes: 50, 100

Stainless Steel, CF8-M (316)  
Optional mesh sizes: 60, 80, 100

Screens are stainless steel

**SCHEMATIC SYMBOL**

The Model 159 Y-Strainer is shown on OCV Valve Schematics as:

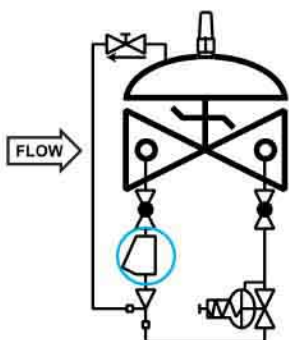

EXAMPLE: Shown here on a MODEL 127-3 Pressure Reducing Valve

**MAINTENANCE**

Routine cleaning and checking of the Y-Strainer will aid in keeping the control valve functioning properly. Pilot system isolation ball valves are supplied on valves equipped with the Model 159 Y-Strainer. These allow flushing of the screen through the blow off port, or removal of the screen itself for manual cleaning.

**DESCRIPTION**

The Model 141-4 Ball Valve is a ¼-turn shutoff device used for isolating the pilot system from the main valve. They are extremely useful for performing routine maintenance and troubleshooting.

Ball valves are standard on water service valves; optional on fuel service valves.

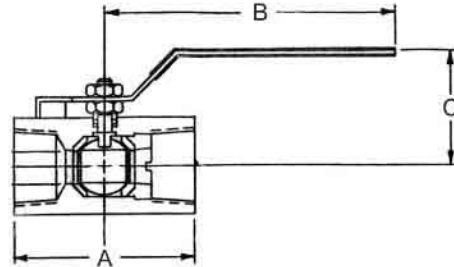

**MODEL 141-4 MATRIX**

MATERIAL	PART NUMBER	INLET/OUTLET (NPT)	A	B	C	USED ON VALVE SIZE*
Bronze	680100	3/8	1 3/4	3 1/2	1 7/8	1 ¼"-6"
Bronze	680101	1/2	2	3 1/2	2 1/4	8"-10"
Bronze	680102	3/4	3	4 3/4	2 1/4	12"-16"
Stn. Steel	680700	3/8	2	3 3/4	2 1/8	1 ¼"-6"
Stn. Steel	680701	1/2	2 1/4	3 3/4	2 1/2	8"-10"
Stn. Steel	680702	3/4	3	4 3/4	2 1/4	12"-16"

**SCHEMATIC SYMBOL**

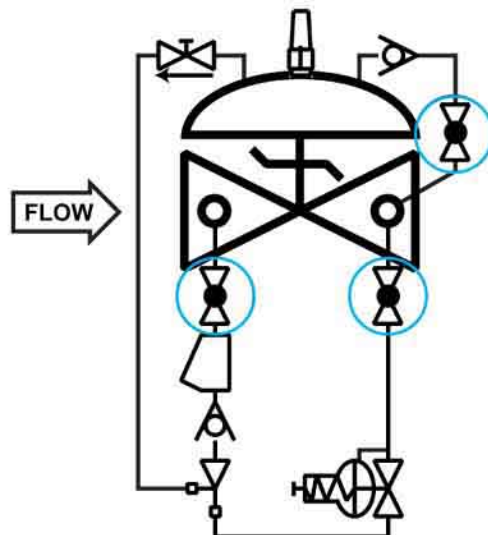

The Model 141-4 Ball Valve is shown on OCV Valve Schematics as:

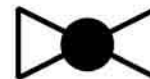

EXAMPLE: Shown here on a MODEL 127-4 Pressure Reducing / Check Valve.