

# solenoid control valve

(energize-to-close)

## installation, operating and maintenance instructions

### model 115-1

#### GENERAL DESCRIPTION

The OCV Model 115-1 is a simple, on-off valve that opens and closes in response to an electrical signal.

The 115-1 consists of the following components, arranged as shown on the schematic diagram:

1. **Model 65 Basic Valve Assembly**, a hydraulically operated, diaphragm actuated globe valve that closes with an elastomer-on-metal seal.
2. **Model 452 Three-Way Solenoid Pilot**, that “converts” the electrical control signals into hydraulic signals to open and close the valve. Applying power to the solenoid causes the valve to close.
3. **Model 141-2 Needle Valve** that controls the speed at which the main valve opens and closes.
4. **Model 159 Y-Strainer** that protects the pilot system from solid contaminants in the line fluid.
5. Two **Model 141-4 Ball Valves**, useful for isolating the pilot system for maintenance or repair.
6. **Model 155 Visual Indicator Assembly** (optional) that enables the user to determine the valve’s operating position at a glance.

#### THEORY OF OPERATION

**ELECTRICAL ON-OFF ACTION:** Applying power to the **solenoid pilot (2)** shifts the pilot to connect Port P to Port A and block Port R. This allows full inlet pressure to build up in the diaphragm chamber of the **main valve (1)**, forcing the valve fully and tightly closed.

Removing power from the solenoid pilot shifts the pilot to connect Port A to Port R and block Port P. This ex-

hausts pressure on the diaphragm chamber of the main valve to atmosphere, allowing the valve to open fully.

To summarize, energizing the solenoid causes the valve to close; deenergizing the solenoid causes the valve to open.

#### INSTALLATION

The 115-1 is furnished fully factory-assembled and ready for installation at the appropriate point in the system. For full installation details, the user is referred to the Model 65 Basic Valve section of this manual.

Once the main valve is installed, the solenoid pilot must be wired into the control circuit. This is a simple two-wire hookup.

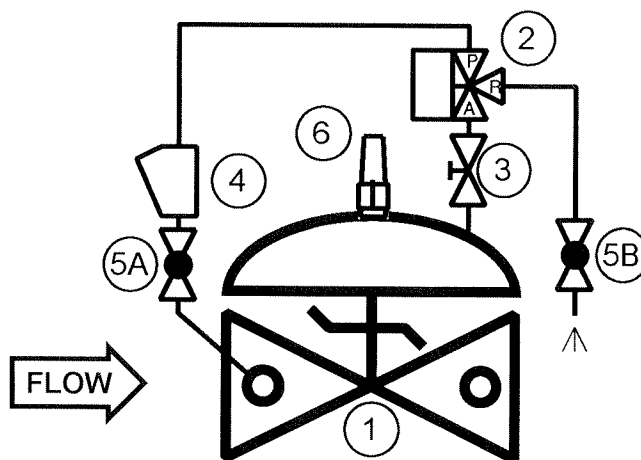

## STARTUP AND ADJUSTMENTS

The following procedures should be followed in the order presented in order to effect an initial startup the 115-1.

1. Energize\* the solenoid pilot (2).
2. Loosen the jam nut on the needle valve (3). Turn the adjusting screw fully clockwise, then counterclockwise three full turns.
3. Carefully loosen a pipe plug in the main valve bonnet until fluid begins to discharge around the threads. When only clear fluid (no air) is discharging, retighten the plug.
5. Deenergize the solenoid. Observe that the main valve opens.
6. Energize\* the solenoid. Observe that the main valve closes.
7. Adjust the needle valve (3) for the opening/closing speed that best suits the operating conditions. **Clockwise** adjustment will **decrease** the opening/closing speed. However, do NOT adjust fully clockwise, as this will prevent the valve from operating.

\*NOTE: The valve can be operated in the absence of electrical power by the use of the manual override device on the side of the solenoid coil. Simply push the button in to momentarily open the valve. Or push in and turn 90° clockwise for sustained manual override. *Make sure that the manual override device is OFF (button counterclockwise and out) when the valve is placed under electrical operation.*

## MAINTENANCE

Because of the simplicity of design of the 115-1, required maintenance is minimal. However, the following checks, periodically performed, can do much to keep the valve operating properly and efficiently.

1. Check for chipped or peeling paint. Touch up as required.
2. Check for leaks at fittings and around flanges and connections. Tighten as required.
3. Check that electrical wiring and connections are secure.

## TROUBLESHOOTING

In the event of malfunction of the 115-1, the following guide should enable the technician to isolate the specific cause of the problem and take the appropriate corrective action.

### MAIN VALVE FAILS TO OPEN

1. Valve closed downstream of 115-1 — Open as required.
2. Solenoid not deenergized or manual override actuated — Check control system or take solenoid out of manual override.
3. Needle valve (3) fully closed — Open as required. See Adjustment instructions.
4. Stem of main valve (1) binding — Disassemble valve and determine cause. See the Model 65 Basic Valve section of this manual.

### MAIN VALVE FAILS TO CLOSE

1. Solenoid pilot (2) not energized — Check control system.
2. Activate the manual override on the solenoid. If the valve closes, the coil may be burned out. Otherwise, proceed to Step 3.
3. Needle valve (3) fully closed — Open as required. See Adjustment instructions.
4. Strainer (4) clogged — Clean as required.
6. Solenoid pilot (2) stuck open or seats deteriorated — See the Solenoid Valve section of this manual.
7. Stem of main valve (1) binding, diaphragm ruptured, or object caught in valve — Disassemble valve and determine cause. See the Model 65 Basic Valve section of this manual.



# installation, operating, and maintenance instructions

## series 65 basic control valve

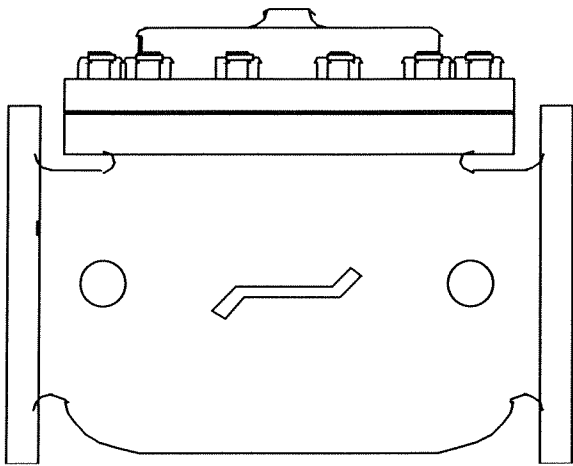

### GENERAL DESCRIPTION

The OCV Series 65 is a hydraulically-operated, diaphragm-actuated valve. It is available in either a globe (Model 65) or angle (Model 65A) configuration. The diaphragm is nylon-fabric bonded with synthetic rubber and forms a sealed chamber in the upper portion of the valve, separating operating pressure from line pressure. An elastomeric seat disc forms a tight seal with the valve seat when pressure is applied above the diaphragm.

### FUNCTIONAL DESCRIPTION

Because the Series 65 is a hydraulically operated valve, it requires a minimum line pressure of approximately 5 psig in order to function. The valve functions on a simple principle of pressure differential. The line pressure at the inlet of the valve is bypassed through the pilot control piping to the diaphragm chamber of the valve. This pressure, together with the valve spring, works against the pressure under the valve seat. Because the effective area of the diaphragm is greater than that of the seat, the valve is held tightly closed. As the controlling pilot(s) allow the pressure to bleed off the diaphragm chamber, the two opposing pressures begin to balance and the valve will begin to open. The valve can be used to perform a simple on-off function, or with the proper pilot system, a modulating, or regulating function.

In cases where the line fluid is unusually dirty, or is otherwise unsuitable for operating the valve, an independent operating pressure source may be employed. The pressure available from such a source must be equal to, or greater than, line pressure.

### INSTALLATION

In order to insure safe, accurate and efficient operation of the OCV control valve, the following list of checkpoints and procedures should be followed when installing the

valve.

1. Make a careful visual inspection of the valve to insure that there has been no damage to the external piping, fittings or controls. Check that all fittings are tight.
2. Thoroughly flush all interconnecting piping of chips, scale and foreign matter prior to mounting the valve.
3. Install the valve in the line according to the flow arrow on the inlet flange. The arrow should point downstream.
4. Allow sufficient room around the valve for ease of adjustment and maintenance service.

In addition, it is highly recommended that:

1. Isolation valves (eg., gate or butterfly) be installed on the inlet and discharge sides of the valve to facilitate isolating the valve for maintenance.
2. Pressure gauges be installed at the inlet and outlet sides of the valve to provide monitoring of the valve during initial start-up and during operation. The body side ports, if unused by the pilot system, provide a convenient connection for the gauges.
3. All valves larger than 6" be installed horizontally, i.e., with the bonnet pointed up, for ease of adjustment and maintenance servicing.

### MAINTENANCE

The OCV control valve requires no lubrication and a minimum of maintenance. However, a periodic inspection should be established to determine how the fluid being handled is affecting the efficiency of the valve. In a water system, for example, the fluid velocity as well as the substances occurring in natural waters, such as dissolved minerals and suspended particles, vary in every installation. The effect of these actions or substances must be determined by inspection. It is recommended that an annual inspection, which includes ex-

amination of the valve interior, be conducted. Particular attention should be paid to the elastomeric parts, i.e., the diaphragm and seat disc. Any obviously worn parts should be replaced.

### REPAIR PROCEDURES

In the event of malfunction of the OCV control valve, troubleshooting should be conducted according to the procedures outlined for the specific model of valve. Then, if those steps indicate a problem with the main valve, this section will outline the procedures necessary to correct the problem.

Problems with the main valve can be classed in three basic categories:

1. VALVE FAILS TO OPEN
  - a. Diaphragm damaged\* - See Procedure A
  - b. Stem binding - See Procedure B
2. VALVE FAILS TO CLOSE
  - a. Diaphragm damaged\* - See Procedure A
  - b. Stem binding - See Procedure B
  - c. Object lodged in valve - See Procedure B
3. VALVE OPENS AND CLOSES BUT LEAKS WHEN CLOSED
  - a. Seat disc damaged - See Procedure C
  - b. Seat ring damaged - See Procedure D

\*A diaphragm failure can prevent the valve from either opening or closing, depending on the flow direction. Most water service valves flow "under the seat", in which case a diaphragm failure will keep the valve from closing. On the other hand, most fuel service valves flow "over the seat", in which case a diaphragm failure will keep the valve from opening. To determine which you have, examine the bridge mark cast into the side of the valve body, then compare it with the figures below.

#### PROCEDURE A : DIAPHRAGM REPLACEMENT

1. Isolate the valve from the system by closing upstream and downstream block valves.
2. Loosen one of the tubing connections on the bonnet. Allow any residual pressure to bleed off.
3. Remove all tubing connected at the bonnet.
4. Remove the bonnet nuts.
5. Remove the bonnet. If the bonnet sticks in place, it may be loosened by rapping sharply around its edge with a rubber-headed mallet. *NOTE: 8" and larger valves are equipped with eye bolts through which a chain can be fastened to aid in*

*lifting the bonnet.*

6. Remove the spring.
7. Remove the diaphragm plate capscrews and the diaphragm plate.
8. Remove the old diaphragm.
9. Making sure the dowel pin holes are in the proper location, place the new diaphragm over the studs and press down until it is flat against the body and spool.
10. Replace the diaphragm plate and the diaphragm plate capscrews.
11. Tighten all diaphragm plate capscrews snugly.
12. Replace the spring.
13. Replace the bonnet and reinstall the bonnet nuts.
14. Tighten the bonnet nuts snugly using a criss-cross tightening pattern.
15. Reinstall the control tubing.
16. Reopen the upstream and downstream block valves.
17. Before placing the valve back in service, perform the air bleed procedure described in the first section of this manual.

#### PROCEDURE B: CORRECTION OF BINDING STEM

1. Perform Steps 1 thru 6 of Procedure A, above.
2. Remove the spool assembly from the valve. *NOTE:*

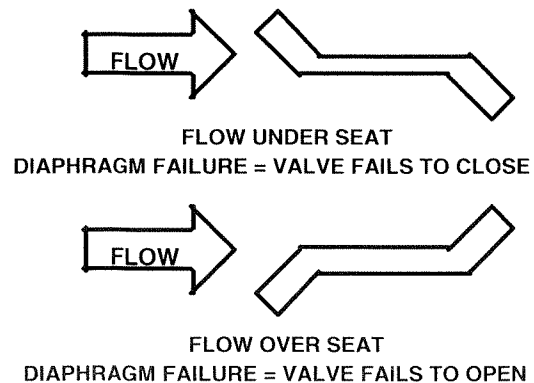

*On smaller valves, this can be accomplished simply by grasping the stem and pulling upward. Valves 6" and larger have the top of the stem threaded to accept an eyebolt to aid in lifting the spool out of the body. 6" thru 12" valves are threaded 3/8-16. 14" and 16" valves are threaded 5/8-11.*

3. Carefully examine both ends of the stem for deep scratches, scoring or buildup of mineral deposits.

Polish the stem if necessary using a fine grade of emery cloth.

4. Similarly, examine and polish the upper bushing (in the bonnet) and the lower guide (in the seat ring).
5. Reinstall the spool assembly.
6. Reassemble the valve, following Steps 12 thru 17 in Procedure A.

**PROCEDURE C: SEAT DISC REPLACEMENT**

1. Perform Steps 1 and 2 of Procedure B, above.
2. With the spool assembly removed from the body, remove the seat retainer screws.
3. Slide the seat retainer off the lower end of the stem.
4. Remove the seat disc from its groove in the spool.  
*NOTE: The seat disc may fit quite tightly in the groove. If necessary, it may be pried out using a thin-bladed screwdriver or similar tool.*
5. Install the new seat disc in the groove.
6. Reinstall the seat retainer and tighten the seat retainer screws.
7. Reassemble the valve, following Steps 5 and 6 of Procedure B.

**PROCEDURE D: SEAT RING REPLACEMENT**

*NOTE: It is rare for a seat ring to require replacement. Minor nicks and scratches in the seating surface can usually be smoothed out with emery cloth.*

1. Perform Steps 1 and 2 of Procedure B, above.
2. If you are working on a 4" or smaller valve, follow Steps 3 thru 9, below.
3. If you are working on a 6" or larger valve, follow Steps 10 thru 16, below.

4. Seat rings in valves 4" and smaller are threaded into the valve body. To remove, you will need a special seat ring tool. You may fabricate one using standard pipe as shown in the sketch below, or one may be purchased from OCV.
5. Using the seat ring tool, unthread the seat ring from the body.
6. Remove the old o-ring from the counterbore in the body.
7. Install the new o-ring in the counterbore.
8. Using the seat ring tool, install the new seat ring.
9. Reassemble the valve, following Steps 5 & 6 of Procedure B.
10. Seat rings in valves 6" and larger are bolted into the body with socket head capscrews. In addition you will note that the seat ring is equipped with additional threaded holes that may be used for "jacking" the seat ring out of the body.
11. Remove the socket head capscrews.
12. Remove the old seat ring from the body by temporarily installing two or more of the capscrews in the "jacking" holes.
13. Install a new o-ring in the groove of the new seat ring. Lubricate the o-ring and outer seat ring wall with Vaseline® or similar lubricant.
14. Install the new seat ring in the body, making sure that the capscrew holes line up.
15. Replace and tighten all the capscrews.
16. Reassemble the valve, following Steps 5 and 6 of Procedure B.

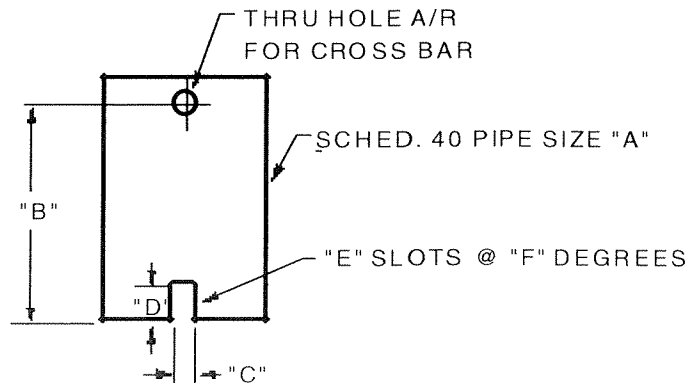

VALVE SIZE	"A" PIPE SIZE	"B" MIN. LENGTH	"C" SLOT WIDTH	"D" SLOT DEPTH	"E" NO. OF SLOTS	"F" SLOT SPACING
1-1/4"	3/4"	6"	3/8"	3/8"	2	180°
1-1/2"	3/4"	6"	3/8"	3/8"	2	180°
2"	1-1/2"	7"	3/8"	3/8"	2	180°
2-1/2"	2"	8"	1/2"	1/2"	3	120°
3"	2-1/2"	9"	5/8"	5/8"	2	180°
4"	3"	10"	5/8"	5/8"	2	180°

REVISED 3-17-97

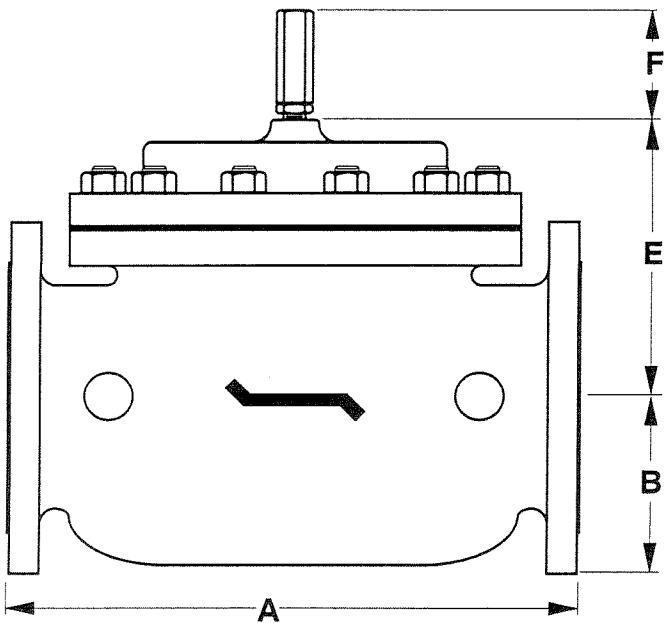
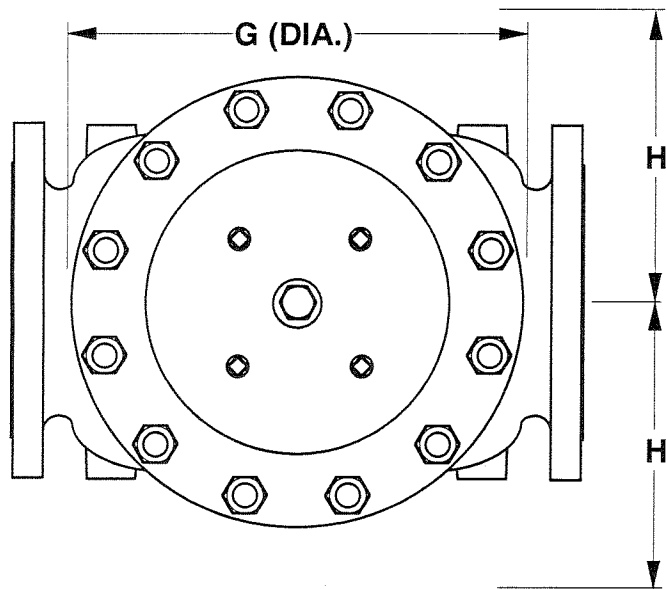

DIM	ANSI CLASS	VALVE SIZE												
		1 1/4	1 1/2	2	2 1/2	3	4	6	8	10	12	14	16	24
A	SE	8.75	8.75	9.88	10.50	13.00	-	-	-	-	-	-	-	-
	150	8.50	8.50	9.38	10.50	12.00	15.00	17.75	25.38	29.75	34.00	39.00	40.38	62.00
	300	8.75	8.75	9.88	11.12	12.75	15.62	18.62	26.38	31.12	35.50	40.50	42.00	63.75
B	SE	1.44	1.44	1.69	1.88	2.25	-	-	-	-	-	-	-	-
	150	2.31	2.50	3.00	3.50	3.75	4.50	5.50	6.75	8.00	9.50	10.62	11.75	16.00
	300	2.62	3.06	3.25	3.75	4.12	5.00	6.25	7.50	8.75	10.25	11.50	12.75	18.00
C	SE	4.38	4.38	4.75	6.00	6.50	-	-	-	-	-	-	-	-
	150	4.25	4.25	4.75	6.00	6.00	7.50	10.00	12.69	14.88	17.00	-	20.81	-
	300	4 3/8	4.38	5.00	6.38	6.38	7.81	10.50	13.19	15.56	17.75	-	21.62	-
D	SE	3.12	3.12	3.88	4.00	4.50	-	-	-	-	-	-	-	-
	150	3.00	3.00	3.88	4.00	4.00	5.50	6.00	8.00	11.38	11.00	-	15.69	-
	300	3.25	3.25	4.12	4.38	4.38	5.81	6.50	8.50	12.06	11.75	-	16.50	-
E	ALL	6.00	6.00	6.00	7.00	6.50	7.92	10.00	11.88	15.38	17.00	18.00	19.00	27.00
F	ALL	3.88	3.88	3.88	3.88	3.88	3.88	3.88	6.38	6.38	6.38	6.38	6.38	8.00
G	ALL	6.00	6.00	6.75	7.69	8.75	11.75	14.00	21.00	24.50	28.00	31.25	34.50	52.00
H	ALL	10.00	10.00	11.00	11.00	11.00	12.00	13.00	14.00	17.00	18.00	20.00	20.00	28.50

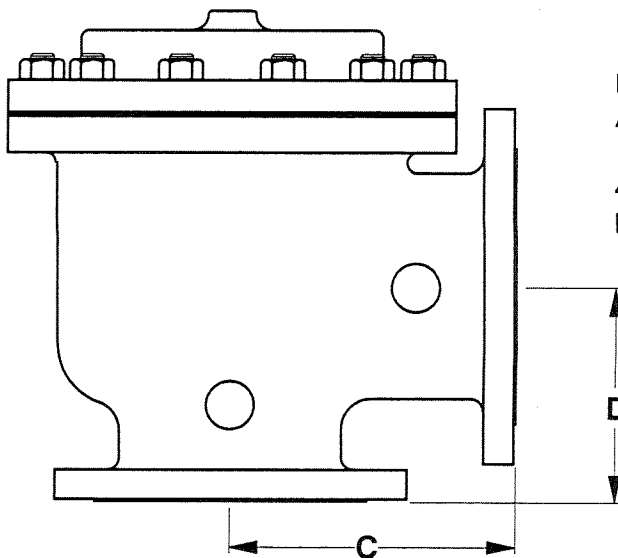

NOTE: 3" VALVE DIMENSIONS ARE FOR NEW MODEL 3100

4" VALVE DIMENSIONS ARE FOR NEW MODEL 4400

REV. A SDJ 6-6-02  
REV. B SDJ 2-3-03

<b>TOLERANCES</b>		 <b>OCV Control Valves</b> TULSA, OKLAHOMA U.S.A.	
UNLESS NOTED FRACTIONAL $\pm 1/64$ DECIMAL $\pm .005$ MACH. FINISH 125/ $\sqrt{\text{ }}$ ANGULAR $\pm 1/2^\circ$			
<b>GENERAL VALVE DIMENSIONS</b>			
DRAWN BY SDJ	DATE 10-6-97	SIZE	DRAWING NUMBER
CHKD. BY	DATE	<b>A</b>	<b>65D</b>
			REV. <b>B</b>

# INSTALLATION & MAINTENANCE INSTRUCTIONS

**ASCO.**

BULLETIN

8320

Form No. V5688R2

3-WAY SOLENOID VALVES — NORMALLY OPEN,  
NORMALLY CLOSED, AND UNIVERSAL OPERATION  
1/4" NPT — BRASS AND STAINLESS STEEL CONSTRUCTION

## DESCRIPTION

Bulletin 8320 valves are small 3-way solenoid valves with all three connections located in the body. Valve bodies are made of brass or stainless steel.

Standard valves have a Type 1, General Purpose Solenoid Enclosure. Valves may also be provided with an explosion-proof solenoid enclosure designed to meet Enclosure Type 3-Raintight, Type 7 (C & D)-Explosion-Proof Class I, Groups C & D and Type 9 (E, F, & G)-Dust Ignition-Proof Class II, Groups E, F, & G, and have a temperature range code of TC3. Installation and maintenance instructions for the explosion-proof solenoid enclosure are on Form No. V5380.

## OPERATION

### Normally Open (Pressure at 3)

Applies pressure when solenoid is de-energized; exhausts pressure when solenoid is energized. When solenoid is de-energized, flow is from Port "3" to Port "1." Port "2" is closed. When solenoid is energized, flow is from Port "1" to "2." Port "3" is closed.

### Normally Closed (Pressure at 2)

Applies pressure when solenoid is energized; exhausts pressure when solenoid is de-energized. When solenoid is de-energized, flow is from Port "1" to Port "3." Port "2" is closed. When solenoid is energized, flow is from Port "2" to Port "1." Port "3" is closed.

### Universal (Pressure at 1, 2, or 3)

For normally closed or normally open operation, selection or diversion of pressure can be applied to Ports "1", "2", or "3."

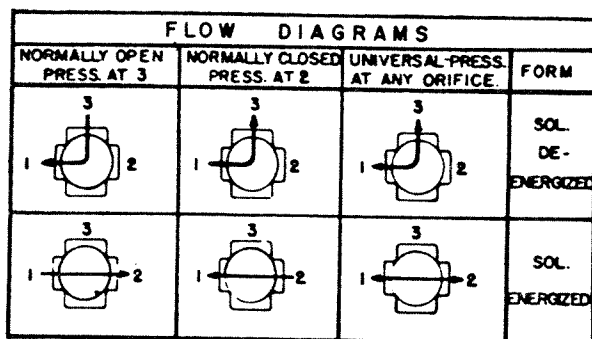

## Manual Operator (Optional)

Manual operator allows manual operation when desired or during an electrical power outage. Two types of manual operators are available - push type (Suffix MO) and screw type (Suffix MS). To operate valve manually with push type operator, push stem at base of valve body as far upward as possible. Valve will now be in the same position as when the solenoid is energized. Removing pressure from stem will release manual operator to original position. To operate valve with a screw type manual operator, rotate manual operator stem at base of valve body clockwise until it hits a stop. Valve will now be in the same position as when the solenoid is energized. Rotate manual operator stem fully counterclockwise before operating valve electrically.

## INSTALLATION

Check nameplate for correct catalog number, pressure, voltage, frequency, and service.

## Temperature Limitations

For maximum valve ambient and fluid temperatures, refer to chart below. Check catalog number prefix and watt rating on nameplate to determine the maximum temperatures. See example below chart.

Construction AC or DC	Catalog Number Prefix	Watts	Maximum Ambient Temp. °F	Maximum Fluid Temp. °F
AC	None, DA, or S	10.5	77	200
	DF, FT, or SF	10.5	122	200
	HT	10.5	140	200
	None, DP, or SP	16.7*	77	200
DC	None, FT, or HT	11.2*	77	150

\* Catalog Nos. 8320A 170, 8320A 180, and 8320A 190 are limited to 140 °F fluid temperature.

EXAMPLES: For Catalog No. HT 8320A 201, AC construction with a watt rating of 10.5, the maximum ambient temperature is 140 °F with a maximum fluid temperature of 200 °F. For Catalog No. 8320A 204, AC construction with a watt rating of 10.5, the maximum ambient temperature is 77 °F with a maximum fluid temperature of 200 °F.

## Positioning

This valve is designed to perform properly when mounted in any position. However, for optimum life and performance, the solenoid should be mounted vertically and upright to reduce the possibility of foreign matter accumulating in the solenoid base sub-assembly area.

## Mounting

For mounting dimensions of body boss (brass) or mounting brackets (optional on brass construction), refer to Figures 1, 2, and 3.

## Piping

Connect piping to valve according to markings on valve body. Refer to flow diagrams provided. Apply pipe compound sparingly to male pipe threads only. If applied to valve threads, the compound may enter the valve and cause operational difficulty. Avoid pipe strain by properly supporting and aligning piping. When tightening the pipe, do not use valve or solenoid as a lever. Locate wrenches applied to valve body or piping as close as possible to connection point.

**IMPORTANT:** To protect the solenoid valve, install a strainer or filter, suitable for the service involved in the inlet side as close to the valve as possible. Clean periodically depending on service conditions. See ASCO Bulletins 8600, 8601, and 8602 for strainers.

## Wiring

Wiring must comply with local codes and the National Electrical Code. Solenoid housings are provided with a 7/8" diameter hole to accommodate 1/2" conduit. On some constructions, a green grounding wire is provided. Use rigid metallic conduit to ground all enclosures not provided with a green grounding wire. To facilitate wiring, the enclosure may be rotated 360° by removing the retaining cap or clip. **WARNING:** When metal retaining clip disengages, it will spring upward. Rotate enclosure to desired position. Then replace retaining cap or clip before operating.

**NOTE:** Alternating current (AC) and direct current (DC) solenoids are built differently. To convert from one to the other, it is necessary to change the complete solenoid, including the solenoid base sub-assembly and core assembly.

Form No. V5688R2

**ASCO Valves**

**ASCO**

Printed in U.S.A.

Automatic Switch Co. 50-60 Hanover Road, Florham Park, New Jersey 07932

© Automatic Switch Co. INCORPORATED. All Rights Reserved.

Standard catalog valves are supplied with coils designed for continuous duty service. When the solenoid is energized for a long period, the solenoid enclosure becomes hot and can be touched by hand only for an instant. This is a safe operating temperature. Any excessive heating will be indicated by the smoke and odor of burning coil insulation.

### MAINTENANCE

**NOTE:** It is not necessary to remove the valve from the pipeline for repairs.  
**WARNING:** Turn off electrical power supply and depressurize valve before making repairs.

#### Cleaning

All solenoid valves should be cleaned periodically. The time between cleanings will vary depending on the medium and service conditions. In general, if the voltage to the coil is correct, sluggish valve operation, excessive noise, or leakage will indicate that cleaning is required. Clean valve strainer or filter when cleaning the valve.

#### Preventive Maintenance

1. Keep the medium flowing through the valve as free from dirt and foreign material as possible.
2. While in service, the valve should be operated at least once a month to insure proper opening and closing.
3. Depending on the medium and service conditions, periodic inspection of internal valve parts for damage or excessive wear is recommended. Thoroughly clean all parts. Replace worn or damaged parts. However, for best results, replace all parts as supplied with an ASCO Rebuild Kit.

#### Causes Of Improper Operation

1. **Faulty Control Circuits:** Check the electrical system by energizing the solenoid. A metallic "click" signifies that the solenoid is operating. Absence of the "click" indicates loss of power supply. Check for loose or blown fuses, open circuited or grounded coil, broken lead wires or splice connections.
2. **Burned-Out Coil:** Check for open-circuited coil. Replace coil as necessary. Check supply voltage; it must be the same as specified on nameplate.
3. **Low Voltage:** Check voltage across the coil lead. Voltage must be at least 85% of nameplate rating.
6. **Incorrect Pressure:** Check valve pressure. Pressure to valve must be within range specified on nameplate.
5. **Excessive Leakage:** Disassemble valve (see Maintenance) and clean all parts. Replace worn or damaged parts. However, for best results, replace all parts as supplied with an ASCO Rebuild Kit.

#### Coil Replacement (Refer to Figures 4 and 5)

**WARNING:** Turn off electrical power supply.

1. Disconnect coil lead wires.
2. Remove retaining cap or clip, nameplate and housing. **WARNING:** When metal retaining clip disengages, it will spring upward.
3. Remove spring washer, insulating washer, coil, insulating washer, ground wire terminal (if present) from solenoid base sub-assembly. Insulating washers are omitted when a molded coil is used.
4. Reassemble in reverse order of disassembly. Use exploded view provided for identification and placement of parts.

**CAUTION:** The solenoid must be fully reassembled because the housing and internal parts complete the magnetic circuit. Be sure to replace insulating washer at each end of the non-molded coil.

#### Valve Disassembly (Refer to Figures 4 and 5)

**WARNING:** Depressurize valve and turn off electrical power supply.

1. Disassemble valve in an orderly fashion. Use exploded views for identification and placement of parts.
2. If necessary, disconnect coil lead wires, grounding wire (if present), and rigid conduit from solenoid housing.
3. Remove retaining cap or clip and slip the entire solenoid enclosure off the solenoid base sub-assembly. **WARNING:** When metal retaining clip disengages, it will spring upward.
4. Unscrew solenoid base sub-assembly from valve body.
5. Remove core assembly, core spring, core guide (AC construction only), and solenoid base gasket.
6. Unscrew end cap (or manual operator assembly) and remove end cap gasket, disc holder spring, and disc holder sub-assembly.
7. All parts are now accessible to clean or replace. Replace worn or damaged parts. However, for best results, replace all parts as supplied with an ASCO Rebuild kit.

#### Valve Reassembly

1. Reassemble in reverse order of disassembly. Use exploded views for identification and placement of parts.
2. Lubricate all gaskets with DOW CORNING® 111 Compound lubricant or an equivalent high-grade silicone grease. For stainless steel valve constructions, apply a small amount of LOCTITE® PST® pipe sealant (ASCO No. 208-832-11) to male threads of end cap (or manual operator assembly). Pipe sealant supplied in ASCO Rebuild Kits.

3. Replace disc holder sub-assembly, disc holder spring, end cap gasket, and end cap (or manual operator assembly). For brass construction, torque end cap to  $175 \pm 25$  inch-pounds ( $19,8 \pm 2,8$  newton-meters). For stainless steel, torque end cap to  $90 \pm 10$  inch-pounds ( $10,2 \pm 1,1$  newton-meters).
4. Replace solenoid base gasket, core assembly, core spring, core guide (AC construction only), and solenoid base sub-assembly. Torque solenoid base sub-assembly to  $175 \pm 25$  inch-pounds ( $19,8 \pm 2,8$  newton-meters).
5. Replace solenoid enclosure and retaining cap or clip.
6. Restore line pressure and electrical power supply to valve.
7. After maintenance is completed, operate the valve a few times to be sure of proper operation. A metallic "click" signifies the solenoid is operating.

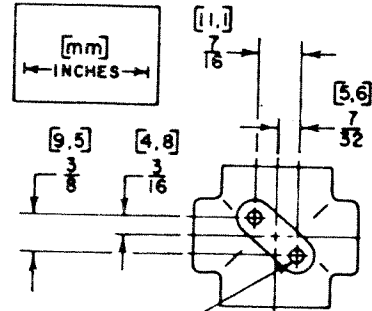

TWO (2) MOUNTING HOLES  
9/32 [7.1] DEEP FOR NO. 8  
THREAD CUTTING SCREW.

Figure 1. Brass Valve Body Mounting

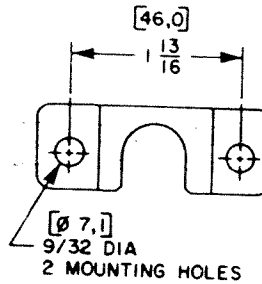

**NOTE:** FOR MOUNTING, A FLAT SURFACE MUST BE PROVIDED ACROSS THE ENTIRE LENGTH OF THE BRACKET. BRACKET MAY BE ROTATED 360°.

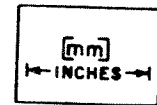
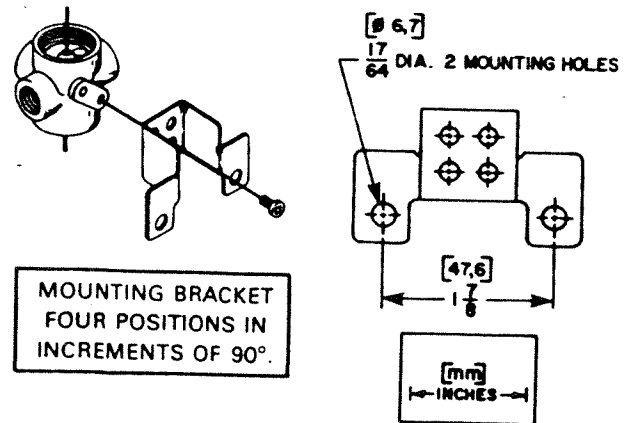

Figure 2. Mounting Bracket for Stainless Steel



MOUNTING BRACKET  
FOUR POSITIONS IN  
INCREMENTS OF 90°.



Figure 3. Optional Mounting Bracket for Brass



**ORDERING INFORMATION  
FOR ASCO REBUILD KITS AND COILS**

Parts marked with an asterisk (\*) in the exploded view are supplied in Rebuild Kits.

- When Ordering Rebuild Kits for ASCO valves, order the Rebuild Kit number stamped on the valve nameplate. +
  - When Ordering Coils for ASCO valves, order the number stamped on your coil. +
- + If the number of the Rebuild Kit or the Coil is not visible, order them and specify your valve's Catalog Number, Serial Number, Voltage, and Frequency.

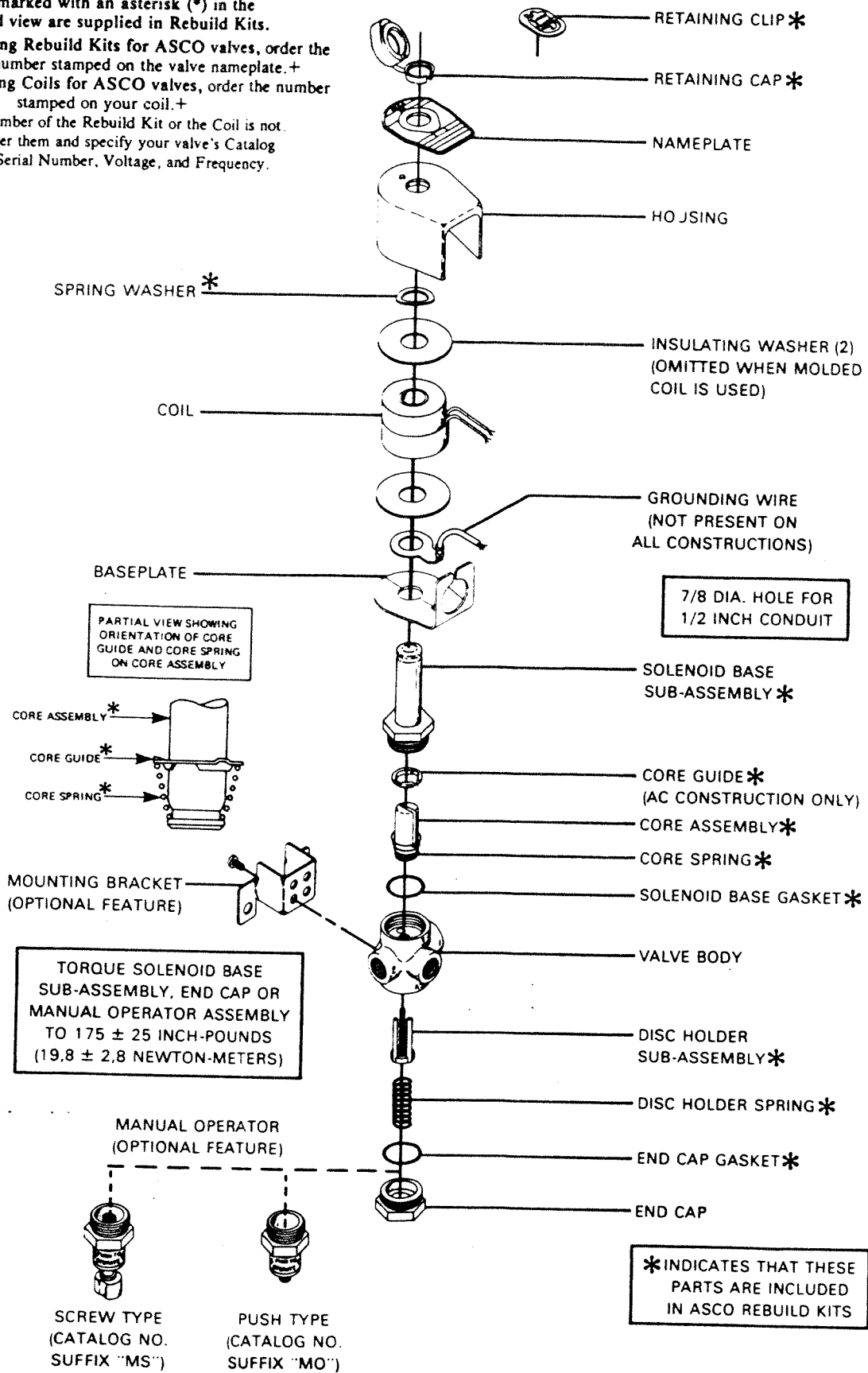

**Figure 4. Bulletin 8320, Brass Construction  
With General Purpose Solenoid Enclosure Shown  
For Explosion-Proof Solenoid Enclosure, See Form No.V5380.**

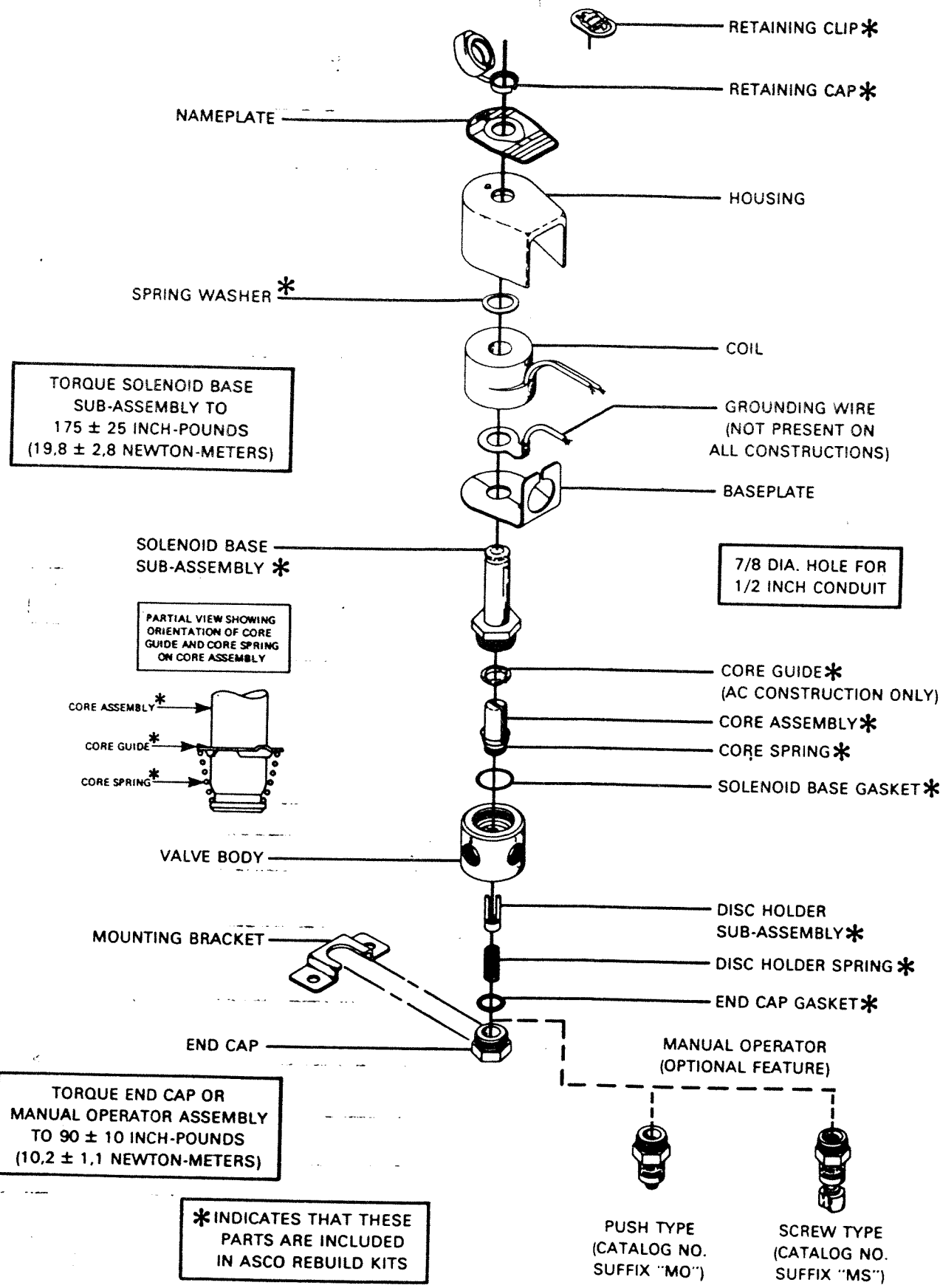

Figure 5. Bulletin 8320, Stainless Steel Construction  
 With General Purpose Solenoid Enclosure Shown.  
 For Explosion-Proof Solenoid Enclosure, See Form No.V5380.

## DESCRIPTION

The Model 141-2 Needle Valve is an adjustable restriction device installed in the control circuit tubing. The setting of the needle valve meters the flow into and out of the main valve diaphragm chamber, thus controlling the response speed of the main valve. Depending on the application, the needle valve may be used as a closing speed control, opening speed control, or both simultaneously.



◀ Needle Valves shown  
Sizes: 3/4" & 1/4"

## MODEL 141-2 MATRIX

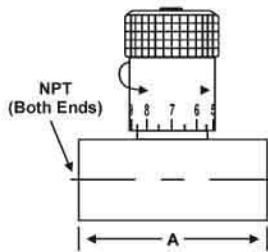

MATERIAL	PART NUMBER	INLET/OUTLET (NPT)	A	USED ON VALVE SIZE*
Brass	683100	1/4	2	1 1/4"-2"
Brass	683101	3/8	2 1/4	2 1/2"-6"
Brass	683102	1/2	2 5/8	8"-10"
Brass	683103	3/4	3 1/4	12"-16"
Stn. Steel	683700	1/4	2	1 1/4"-2"
Stn. Steel	683702	3/8	2 1/4	2 1/2"-6"
Stn. Steel	682704	1/2	2 5/8	8"-10"
Stn. Steel	683703	3/4	3 5/8	12"-16"

Note: Needle valve size may vary on valve application. Consult factory.

## SCHEMATIC SYMBOL

The Model 141-2 Needle Valve is shown on OCV Valve Schematics as:

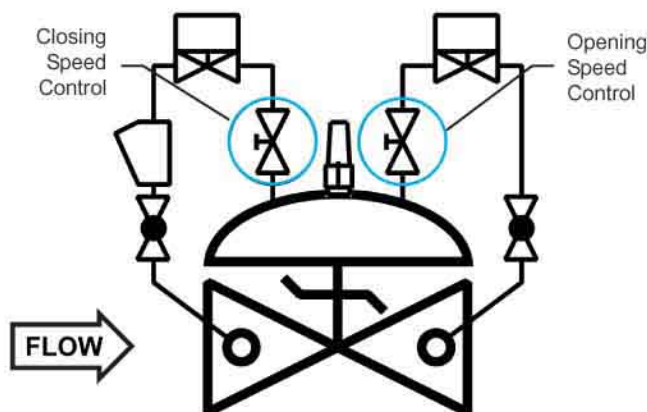
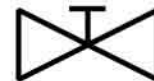

EXAMPLE: Shown here on a MODEL 115-3 DIGITAL VALVE as separate opening and closing speed controls.



**DESCRIPTION**

**MODEL 159 Y-STRAINER**

The 159 Y-Strainer installs in the inlet piping of the pilot system and protects the pilot system from solid contaminants in the line fluid. It is the standard strainer for water service valves.

**MODEL 159 Y-STRAINER MATRIX**

MATERIAL	PART NUMBER	INLET/OUTLET (NPT)	BLOW OFF PORT (NP)	A	STD. MESH	USED ON VALVE SIZE
Bronze	660100	3/8	3/8	2 11/16	24	1 1/4"-6"
Bronze	660101	1/2	3/8	2 5/8	24	8"-10"
Bronze	660102	3/4	3/8	3 5/16	24	12"-16"
Stn. Steel	660700	3/8	1/4	2 1/2	20	1 1/4"-6"
Stn. Steel	660701	1/2	1/4	2 1/2	20	8"-10"
Stn. Steel	660702	3/4	1/4	3 1/8	20	12"-16"

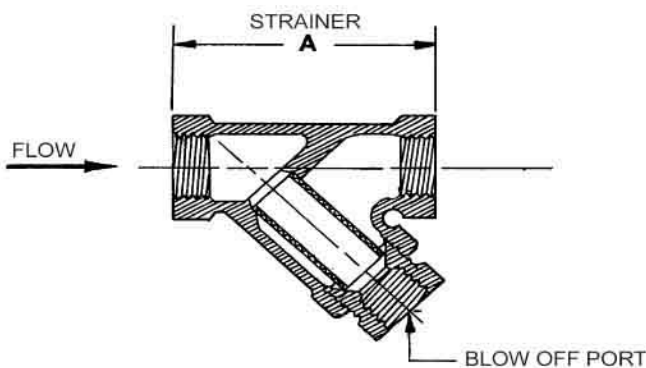

**MATERIALS**

Bronze, ASTM B62  
Optional mesh sizes: 50, 100

Stainless Steel, CF8-M (316)  
Optional mesh sizes: 60, 80, 100

Screens are stainless steel

**SCHEMATIC SYMBOL**

The Model 159 Y-Strainer is shown on OCV Valve Schematics as:

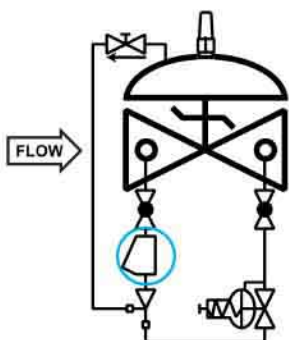

EXAMPLE: Shown here on a MODEL 127-3 Pressure Reducing Valve

**MAINTENANCE**

Routine cleaning and checking of the Y-Strainer will aid in keeping the control valve functioning properly. Pilot system isolation ball valves are supplied on valves equipped with the Model 159 Y-Strainer. These allow flushing of the screen through the blow off port, or removal of the screen itself for manual cleaning.

**DESCRIPTION**

The Model 141-4 Ball Valve is a 1/4-turn shutoff device used for isolating the pilot system from the main valve. They are extremely useful for performing routine maintenance and troubleshooting.

Ball valves are standard on water service valves; optional on fuel service valves.

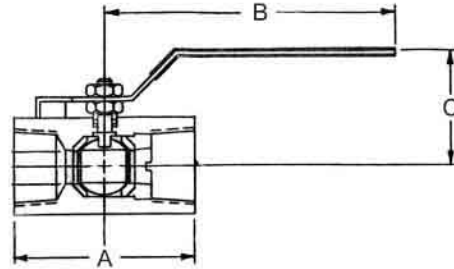

**MODEL 141-4 MATRIX**

MATERIAL	PART NUMBER	INLET/OUTLET (NPT)	A	B	C	USED ON VALVE SIZE*
Bronze	680100	3/8	1 3/4	3 1/2	1 7/8	1 1/4"-6"
Bronze	680101	1/2	2	3 1/2	2 1/4	8"-10"
Bronze	680102	3/4	3	4 3/4	2 1/4	12"-16"
Stn. Steel	680700	3/8	2	3 3/4	2 1/8	1 1/4"-6"
Stn. Steel	680701	1/2	2 1/4	3 3/4	2 1/2	8"-10"
Stn. Steel	680702	3/4	3	4 3/4	2 1/4	12"-16"

**SCHEMATIC SYMBOL**

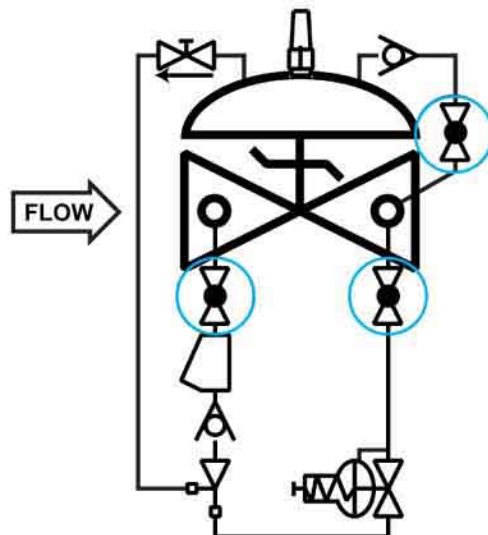

The Model 141-4 Ball Valve is shown on OCV Valve Schematics as:

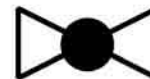

EXAMPLE: Shown here on a MODEL 127-4 Pressure Reducing / Check Valve.

**DESCRIPTION**

The Model 155 Visual Indicator is a device that enables the user to determine the extent of opening of a control valve. It consists of an adaptor threaded into the center port of the valve bonnet, a rod threaded into the main valve stem, a sealing O-ring, and a protective clear plastic housing. The indicator rod moves as the valve opens and closes. It may be installed on virtually any OCV control valve, and can be done so without any disassembly of the valve itself.

**WHERE USED** - Standard on Series 94 Check Valves, Series 3330 Altitude Valves, and Series 22 Digital Control Valves. Optional on any other valve not employing a limit switch or position transmitter.



**MODEL 155 MATRIX**

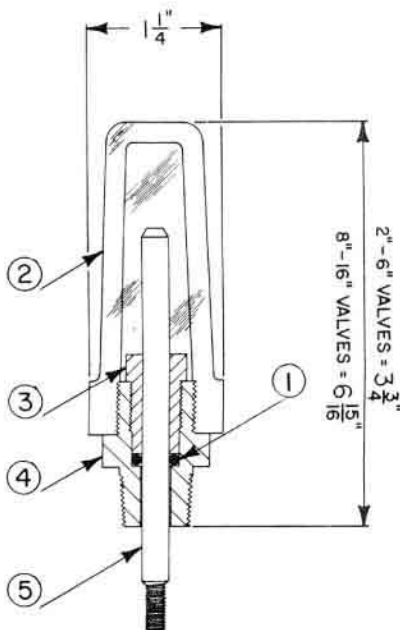

MATERIAL	PART NO. (BRASS ADAPTOR)	PART NO. (STAINLESS ADAPTOR)	VALVE TRAVEL (FULL STROKE)
1 1/4" - 1 1/2"	255100	255700	3/8"
2"	255100	255700	1/2"
2 1/2"	255100	255700	3/4"
3"	255100	255700	1"
4"	255101	255701	1 3/8"
6"	255102	255702	1 1/2"
8" - 10"	255103	255703	2 1/2"
12"	255104	255704	3"
14" - 16"	255105	255705	3 1/2", 4"
24"	255109	255709	6"

ITEM	DESCRIPTION
1	O-Ring
2	Housing
3	Bushing
4	Adaptor
5	Stem

**SCHEMATIC SYMBOL**

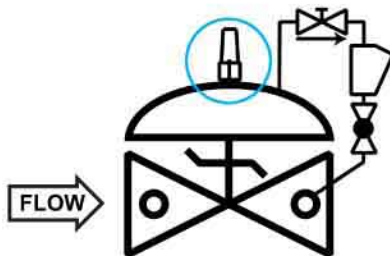

The Model 155 is shown on OCV Valve Schematic as:



EXAMPLE: Shown here on a Model 94-1 Check Valve

**MATERIALS**

- Indicator Rod: Monel
- Adapter: Brass (std.), Stainless Steel (optional)
- Housing: Butyrate (1 1/4" - 6") Acrylic (8" and larger)
- O-Ring: Viton® (std.) Buna-N, EPDM (optional)

**Valve Position Indicator 155**