

# solenoid control valve (energize to open)

## installation, operating, and maintenance instructions

# model 115-2

### GENERAL DESCRIPTION

The OCV Model 115-2 solenoid control valve is designed to open or close in response to an electrical signal. It consists of the following components:

1. **Model 65 Basic Valve**, a hydraulically-operated, diaphragm-actuated, globe or angle valve with an elastomer-on-metal seal.
2. **Model 451 Solenoid Pilot** a two-way, normally-closed, electrically-operated valve. Applying power to the solenoid coil causes this valve to open.
3. **Model 126 Ejector**, a simple "tee" fitting with a fixed orifice in its upstream port. It provides the proper pressure to the diaphragm chamber of the main valve depending on the position of the solenoid.
4. **Model 141-2 Needle Valve** which controls the opening and closing speed of the main valve.
5. **Model 159 Y-Strainer** (standard on water service valves) or **Model 123 Inline Strainer** (standard on fuel service valves). The strainer protects the pilot system from solid contaminants in the line fluid.
6. Two **Model 141-4 Ball Valves** (standard on water service valves, optional on fuel service valves), useful for isolating the pilot system for maintenance or troubleshooting.

At user option, the 115-2 may also be equipped with the

following:

1. Model 155 Visual Indicator.
2. Model 150 Limit Switch Assembly (includes visual indicator).
3. Model 141-3 Flow Control Valve, set up as a closing speed control or as an opening speed control. Or two 141-3's can be provided to give separate, independent control of both closing and opening speeds.

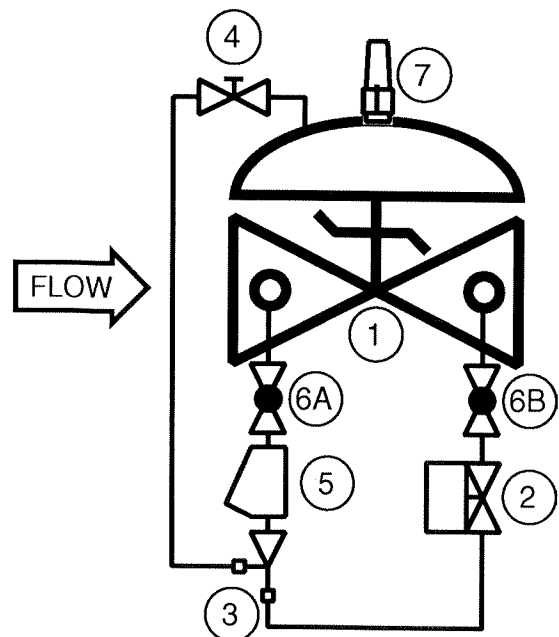

4. Manual override on solenoid pilot.

### **THEORY OF OPERATION** (refer to schematic diagram):

To understand how the 115-2 operates, it is best to begin with the EJECTOR. Due to the orifice in its upstream port, the ejector creates a pressure drop proportional to the flow through it. The flow through the ejector is in turn controlled by the position of the SOLENOID PILOT. If its coil is energized, the solenoid pilot is full open and full flow is allowed through the ejector. The pressure drop through the orifice is at its greatest, which means the **minimum** pressure exists downstream of the orifice.

Now note that the main valve diaphragm chamber is connected at the branch port of the ejector, which is downstream of the orifice. Thus the diaphragm chamber "sees" this low pressure and the main valve opens wide.

When its coil is deenergized, the solenoid pilot goes fully closed. This blocks flow through the ejector which allows full inlet pressure to be applied to the main valve diaphragm chamber. The main valve thus goes fully and tightly closed.

### **INSTALLATION**

The 115-2 is furnished fully factory-assembled and ready for installation at the appropriate point in the system. The user is referred to the Basic Valve section of this manual for full installation details.

Once the main valve is installed, the solenoid pilot is wired into the control system. This is a simple two-wire hookup.

### **STARTUP AND ADJUSTMENT**

The following procedures should be followed in the order presented in order to effect an initial startup of the 115-2.

1. Make sure the coil of the solenoid pilot is deenergized.
2. Turn the adjusting screw of the needle valve fully **clockwise**, then back it off **three full turns**.

3. Start the pump, or otherwise start the system flowing. The main valve will at this time be fully closed.
4. Carefully loosen one of the pipe plugs in the main valve bonnet until fluid appears around the threads. When only clear fluid (no air) is discharging, retighten the plug.
5. Energize the solenoid pilot. Observe that the main valve opens.
6. Deenergize the solenoid pilot and observe that the valve closes.
7. Open and close the valve several times electrically as required to set needle valve for proper opening and closing speed.

### **MAINTENANCE**

Because of the simplicity of design of the 115-2, required maintenance is minimal. However, the following checks, periodically performed, can do much to keep the valve operating properly and efficiently.

1. Check for chipped or peeling paint. Touch up as required.
2. Check for leaks at fittings and around flanges and connections. Tighten as required.
3. Check for frayed or loose electrical connections.
4. If the valve is equipped with a Y-strainer, check the screen for buildup of solid material. Clean as required. This point is most important, as a clogged strainer can keep the valve from closing. On new installations, it is recommended that the strainer be checked every day or two until experience dictates a greater or lesser interval. Strainer maintenance is covered in detail on a special page later in this manual.

### **TROUBLESHOOTING**

In the event of malfunction of the 115-2, the following guide should enable the technician to isolate the specific cause of the problem and take the appropriate corrective action.

**A. MAIN VALVE FAILS TO OPEN:**

1. Valve closed upstream or downstream of the 115-2. Open as required.
2. Downstream pilot system ball valve closed. Open as required.
3. Solenoid not energized. Check electrical system.
4. Needle valve fully closed. See Adjustment instructions.
5. Solenoid pilot stuck closed or coil burned out. See Solenoid Valve section of this manual.
6. Stem of main valve binding. Disassemble valve and determine cause. See the Model 65 Basic Valve section of this manual.

**B. MAIN VALVE FAILS TO CLOSE:**

1. Upstream pilot system ball valve closed. Open as required.
2. Solenoid not deenergized. Check electrical system.
3. Strainer clogged. Clean as required.
4. Close downstream pilot system ball valve.
  - a. If main valve closes, proceed to Step 5.
  - b. If main valve remains open, proceed to Step 6.
5. Solenoid pilot stuck open. See Solenoid Valve section of this manual.
6. Close both pilot system ball valves and loosen a pipe plug in the main valve bonnet. A **continuous** discharge of fluid from the loosened plug indicates that the main valve diaphragm is ruptured. Replace diaphragm. See the Model 65 Basic valve section of this manual.

on the upstream end, the valve is "fail closed." If the bridge mark slants **upward** on the upstream end, the valve is "fail open."

7. Main valve stem binding or object in valve. Disassemble valve and determine cause. See Basic Valve section of this manual.

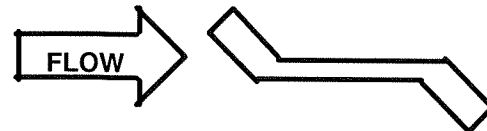

FLOW UNDER SEAT  
DIAPHRAGM FAILURE = VALVE FAILS TO CLOSE

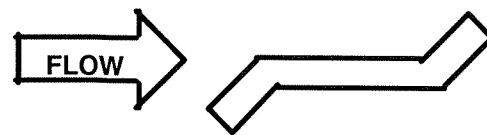

FLOW OVER SEAT  
DIAPHRAGM FAILURE = VALVE FAILS TO OPEN

**NOTE:** Certain valves, predominantly those in fuel service, are assembled "fail closed." In this case, a ruptured diaphragm would keep the valve from opening, rather than keep it from closing. To determine which type you have, examine the "bridge mark" cast into the side of the main valve body and compare it with the diagram below. If the bridge mark slants **downward**

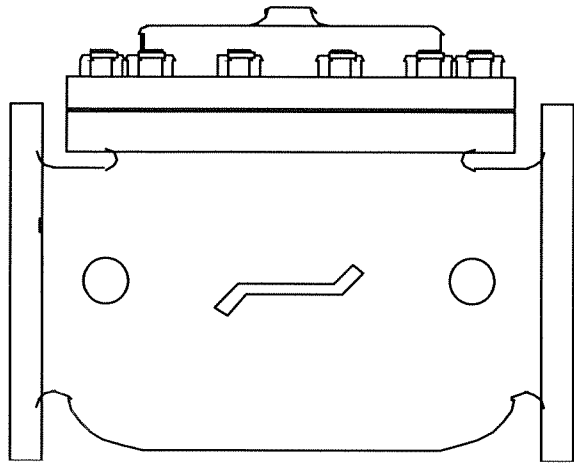

# installation, operating, and maintenance instructions

## series 65 basic control valve

### GENERAL DESCRIPTION

The OCV Series 65 is a hydraulically-operated, diaphragm-actuated valve. It is available in either a globe (Model 65) or angle (Model 65A) configuration. The diaphragm is nylon-fabric bonded with synthetic rubber and forms a sealed chamber in the upper portion of the valve, separating operating pressure from line pressure. An elastomeric seat disc forms a tight seal with the valve seat when pressure is applied above the diaphragm.

### FUNCTIONAL DESCRIPTION

Because the Series 65 is a hydraulically operated valve, it requires a minimum line pressure of approximately 5 psig in order to function. The valve functions on a simple principle of pressure differential. The line pressure at the inlet of the valve is bypassed through the pilot control piping to the diaphragm chamber of the valve. This pressure, together with the valve spring, works against the pressure under the valve seat. Because the effective area of the diaphragm is greater than that of the seat, the valve is held tightly closed. As the controlling pilot(s) allow the pressure to bleed off the diaphragm chamber, the two opposing pressures begin to balance and the valve will begin to open. The valve can be used to perform a simple on-off function, or with the proper pilot system, a modulating, or regulating function.

In cases where the line fluid is unusually dirty, or is otherwise unsuitable for operating the valve, an independent operating pressure source may be employed. The pressure available from such a source must be equal to, or greater than, line pressure.

### INSTALLATION

In order to insure safe, accurate and efficient operation of the OCV control valve, the following list of checkpoints and procedures should be followed when installing the

valve.

1. Make a careful visual inspection of the valve to insure that there has been no damage to the external piping, fittings or controls. Check that all fittings are tight.
2. Thoroughly flush all interconnecting piping of chips, scale and foreign matter prior to mounting the valve.
3. Install the valve in the line according to the flow arrow on the inlet flange. The arrow should point downstream.
4. Allow sufficient room around the valve for ease of adjustment and maintenance service.

In addition, it is highly recommended that:

1. Isolation valves (eg., gate or butterfly) be installed on the inlet and discharge sides of the valve to facilitate isolating the valve for maintenance.
2. Pressure gauges be installed at the inlet and outlet sides of the valve to provide monitoring of the valve during initial start-up and during operation. The body side ports, if unused by the pilot system, provide a convenient connection for the gauges.
3. All valves larger than 6" be installed horizontally, i.e., with the bonnet pointed up, for ease of adjustment and maintenance servicing.

### MAINTENANCE

The OCV control valve requires no lubrication and a minimum of maintenance. However, a periodic inspection should be established to determine how the fluid being handled is affecting the efficiency of the valve. In a water system, for example, the fluid velocity as well as the substances occurring in natural waters, such as dissolved minerals and suspended particles, vary in every installation. The effect of these actions or substances must be determined by inspection. It is recommended that an annual inspection, which includes ex-

amination of the valve interior, be conducted. Particular attention should be paid to the elastomeric parts, i.e., the diaphragm and seat disc. Any obviously worn parts should be replaced.

### REPAIR PROCEDURES

In the event of malfunction of the OCV control valve, troubleshooting should be conducted according to the procedures outlined for the specific model of valve. Then, if those steps indicate a problem with the main valve, this section will outline the procedures necessary to correct the problem.

Problems with the main valve can be classed in three basic categories:

1. VALVE FAILS TO OPEN
  - a. Diaphragm damaged\* - See Procedure A
  - b. Stem binding - See Procedure B
2. VALVE FAILS TO CLOSE
  - a. Diaphragm damaged\* - See Procedure A
  - b. Stem binding - See Procedure B
  - c. Object lodged in valve - See Procedure B
3. VALVE OPENS AND CLOSES BUT LEAKS WHEN CLOSED
  - a. Seat disc damaged - See Procedure C
  - b. Seat ring damaged - See Procedure D

\*A diaphragm failure can prevent the valve from either opening or closing, depending on the flow direction. Most water service valves flow "under the seat", in which case a diaphragm failure will keep the valve from closing. On the other hand, most fuel service valves flow "over the seat", in which case a diaphragm failure will keep the valve from opening. To determine which you have, examine the bridge mark cast into the side of the valve body, then compare it with the figures below.

#### PROCEDURE A : DIAPHRAGM REPLACEMENT

1. Isolate the valve from the system by closing upstream and downstream block valves.
2. Loosen one of the tubing connections on the bonnet. Allow any residual pressure to bleed off.
3. Remove all tubing connected at the bonnet.
4. Remove the bonnet nuts.
5. Remove the bonnet. If the bonnet sticks in place, it may be loosened by rapping sharply around its edge with a rubber-headed mallet. *NOTE: 8" and larger valves are equipped with eye bolts through which a chain can be fastened to aid in*

- lifting the bonnet.*
6. Remove the spring.
  7. Remove the diaphragm plate capscrews and the diaphragm plate.
  8. Remove the old diaphragm.
  9. Making sure the dowel pin holes are in the proper location, place the new diaphragm over the studs and press down until it is flat against the body and spool.
  10. Replace the diaphragm plate and the diaphragm plate capscrews.
  11. Tighten all diaphragm plate capscrews snugly.
  12. Replace the spring.
  13. Replace the bonnet and reinstall the bonnet nuts.
  14. Tighten the bonnet nuts snugly using a criss-cross tightening pattern.
  15. Reinstall the control tubing.
  16. Reopen the upstream and downstream block valves.
  17. Before placing the valve back in service, perform the air bleed procedure described in the first section of this manual.

#### PROCEDURE B: CORRECTION OF BINDING STEM

1. Perform Steps 1 thru 6 of Procedure A, above.
2. Remove the spool assembly from the valve. *NOTE:*

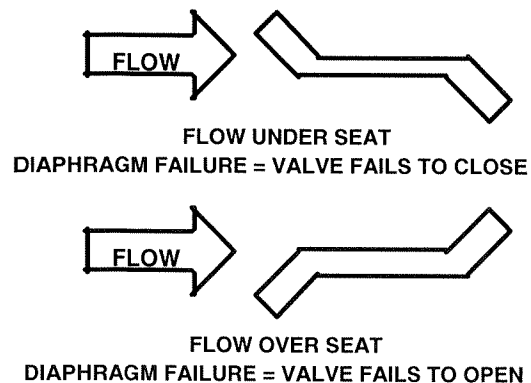

*On smaller valves, this can be accomplished simply by grasping the stem and pulling upward. Valves 6" and larger have the top of the stem threaded to accept an eyebolt to aid in lifting the spool out of the body. 6" thru 12" valves are threaded 3/8-16. 14" and 16" valves are threaded 5/8-11.*

3. Carefully examine both ends of the stem for deep scratches, scoring or buildup of mineral deposits.

- Polish the stem if necessary using a fine grade of emery cloth.
- 4. Similarly, examine and polish the upper bushing (in the bonnet) and the lower guide (in the seat ring).
- 5. Reinstall the spool assembly.
- 6. Reassemble the valve, following Steps 12 thru 17 in Procedure A.

**PROCEDURE C: SEAT DISC REPLACEMENT**

- 1. Perform Steps 1 and 2 of Procedure B, above.
- 2. With the spool assembly removed from the body, remove the seat retainer screws.
- 3. Slide the seat retainer off the lower end of the stem.
- 4. Remove the seat disc from its groove in the spool.  
*NOTE: The seat disc may fit quite tightly in the groove. If necessary, it may be pried out using a thin-bladed screwdriver or similar tool.*
- 5. Install the new seat disc in the groove.
- 6. Reinstall the seat retainer and tighten the seat retainer screws.
- 7. Reassemble the valve, following Steps 5 and 6 of Procedure B.

**PROCEDURE D: SEAT RING REPLACEMENT**

*NOTE: It is rare for a seat ring to require replacement. Minor nicks and scratches in the seating surface can usually be smoothed out with emery cloth.*

- 1. Perform Steps 1 and 2 of Procedure B, above.
- 2. If you are working on a 4" or smaller valve, follow Steps 3 thru 9, below.
- 3. If you are working on a 6" or larger valve, follow Steps 10 thru 16, below.

- 4. Seat rings in valves 4" and smaller are threaded into the valve body. To remove, you will need a special seat ring tool. You may fabricate one using standard pipe as shown in the sketch below, or one may be purchased from OCV.
- 5. Using the seat ring tool, unthread the seat ring from the body.
- 6. Remove the old o-ring from the counterbore in the body.
- 7. Install the new o-ring in the counterbore.
- 8. Using the seat ring tool, install the new seat ring.
- 9. Reassemble the valve, following Steps 5 & 6 of Procedure B.
- 10. Seat rings in valves 6" and larger are bolted into the body with socket head capscrews. In addition you will note that the seat ring is equipped with additional threaded holes that may be used for "jacking" the seat ring out of the body.
- 11. Remove the socket head capscrews.
- 12. Remove the old seat ring from the body by temporarily installing two or more of the capscrews in the "jacking" holes.
- 13. Install a new o-ring in the groove of the new seat ring. Lubricate the o-ring and outer seat ring wall with Vaseline® or similar lubricant.
- 14. Install the new seat ring in the body, making sure that the capscrew holes line up.
- 15. Replace and tighten all the capscrews.
- 16. Reassemble the valve, following Steps 5 and 6 of Procedure B.

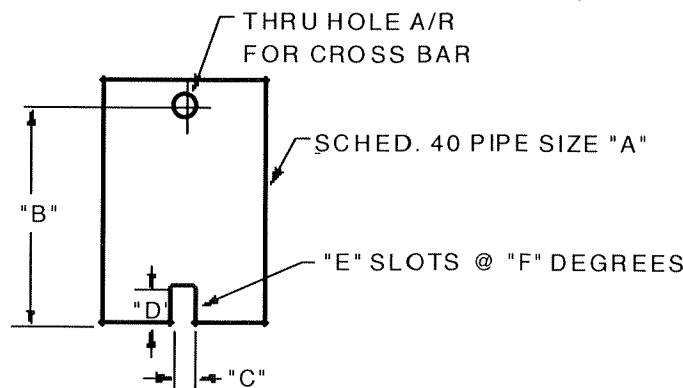

VALVE SIZE	"A" PIPE SIZE	"B" MIN. LENGTH	"C" SLOT WIDTH	"D" SLOT DEPTH	"E" NO. OF SLOTS	"F" SLOT SPACING
1-1/4"	3/4"	6"	3/8"	3/8"	2	180°
1-1/2"	3/4"	6"	3/8"	3/8"	2	180°
2"	1-1/2"	7"	3/8"	3/8"	2	180°
2-1/2"	2"	8"	1/2"	1/2"	3	120°
3"	2-1/2"	9"	5/8"	5/8"	2	180°
4"	3"	10"	5/8"	5/8"	2	180°

REVISED 3-17-97

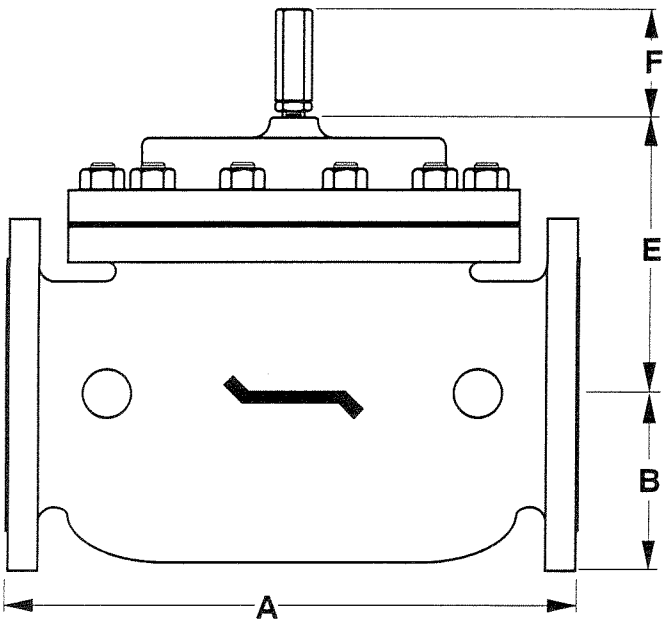
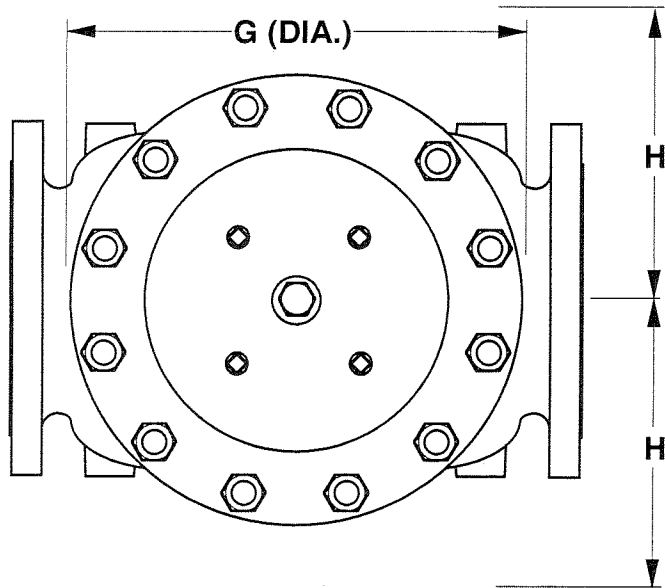

DIM	ANSI CLASS	VALVE SIZE												
		1 1/4	1 1/2	2	2 1/2	3	4	6	8	10	12	14	16	24
A	SE	8.75	8.75	9.88	10.50	13.00	-	-	-	-	-	-	-	-
	150	8.50	8.50	9.38	10.50	12.00	15.00	17.75	25.38	29.75	34.00	39.00	40.38	62.00
	300	8.75	8.75	9.88	11.12	12.75	15.62	18.62	26.38	31.12	35.50	40.50	42.00	63.75
B	SE	1.44	1.44	1.69	1.88	2.25	-	-	-	-	-	-	-	-
	150	2.31	2.50	3.00	3.50	3.75	4.50	5.50	6.75	8.00	9.50	10.62	11.75	16.00
	300	2.62	3.06	3.25	3.75	4.12	5.00	6.25	7.50	8.75	10.25	11.50	12.75	18.00
C	SE	4.38	4.38	4.75	6.00	6.50	-	-	-	-	-	-	-	-
	150	4.25	4.25	4.75	6.00	6.00	7.50	10.00	12.69	14.88	17.00	-	20.81	-
	300	4 3/8	4.38	5.00	6.38	6.38	7.81	10.50	13.19	15.56	17.75	-	21.62	-
D	SE	3.12	3.12	3.88	4.00	4.50	-	-	-	-	-	-	-	-
	150	3.00	3.00	3.88	4.00	4.00	5.50	6.00	8.00	11.38	11.00	-	15.69	-
	300	3.25	3.25	4.12	4.38	4.38	5.81	6.50	8.50	12.06	11.75	-	16.50	-
E	ALL	6.00	6.00	6.00	7.00	6.50	7.92	10.00	11.88	15.38	17.00	18.00	19.00	27.00
F	ALL	3.88	3.88	3.88	3.88	3.88	3.88	3.88	6.38	6.38	6.38	6.38	6.38	8.00
G	ALL	6.00	6.00	6.75	7.69	8.75	11.75	14.00	21.00	24.50	28.00	31.25	34.50	52.00
H	ALL	10.00	10.00	11.00	11.00	11.00	12.00	13.00	14.00	17.00	18.00	20.00	20.00	28.50

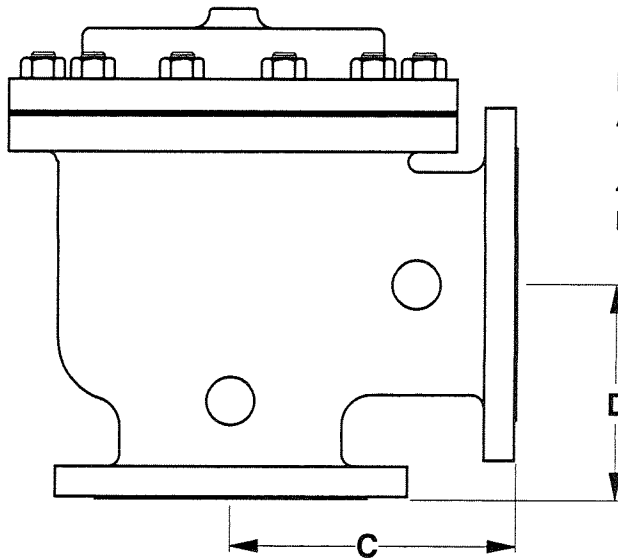

NOTE: 3" VALVE DIMENSIONS ARE FOR NEW MODEL 3100

4" VALVE DIMENSIONS ARE FOR NEW MODEL 4400

REV. A SDJ 6-6-02  
REV. B SDJ 2-3-03

<b>TOLERANCES</b>		 <b>OCV Control Valves</b> TULSA, OKLAHOMA U.S.A.	
UNLESS NOTED FRACTIONAL ±1/64 DECIMAL ±.005 MACH. FINISH 125/ ANGULAR ±1/2°			
<b>GENERAL VALVE DIMENSIONS</b>			
DRAWN BY SDJ	DATE 10-6-97	SIZE <b>A</b>	DRAWING NUMBER <b>65D</b>
CHKD. BY	DATE		REV. <b>B</b>

# INSTALLATION & MAINTENANCE INSTRUCTIONS

2-WAY INTERNAL PILOT-OPERATED SOLENOID VALVES

NORMALLY CLOSED OPERATION

1/2" AND 3/4" NPT - 5/8" ORIFICE

**ASCO.**

BULLETINS

8210

8211

Form No. V5827R1

## DESCRIPTION

Bulletin 8210's are 2-way normally closed, internal pilot-operated solenoid valves, and are made of stainless steel. Standard valves have a General Purpose Type I Solenoid Enclosure.

Bulletin 8211's are the same as Bulletin 8210's except for the solenoid enclosure. Bulletin 8211's have a combination Watertight and Explosion-Proof Solenoid Enclosure designed to meet Enclosure Type 4-Watertight, Type 7 (C and D) Explosion-Proof Class I, Groups C and D and Type 9 (E, F & G) Dust Ignition-Proof Class II, Groups E, F and G. Installation and maintenance instructions for the watertight and explosion-proof solenoid enclosure are on Form No. V5380.

## OPERATION

**Normally Closed:** Valve is closed when solenoid is de-energized; open when energized.

### Manual Operator (Optional)

Valves with suffix "MO" in catalog number are provided with a manual operator which allows manual operation when desired or during an interruption of electrical power. To operate valve manually, rotate stem clockwise 180°. Disengage manual operator by rotating stem counterclockwise 180° before operating electrically.

## INSTALLATION

Check nameplate for correct catalog number, pressure, voltage, frequency, and service.

### Temperature Limitations

For maximum valve ambient and fluid temperatures, refer to chart below. Check catalog number prefix on nameplate to determine maximum temperatures.

CONSTRUCTION	COIL CLASS	CATALOG NUMBER PREFIX	MAXIMUM AMBIENT TEMP. °F	MAXIMUM FLUID TEMP. °F
AC Construction (Alternating Current)	F	NONE	77	175
DC Construction (Direct Current)	A, F or H	None, FT or HT	77	150

### Positioning

This valve is designed to perform properly when mounted in any position. However, for optimum life and performance, the solenoid should be mounted vertically and upright to reduce the possibility of foreign matter accumulating in the solenoid base sub-assembly area.

### Mounting

For mounting bracket (optional feature) mounting dimensions, refer to Figure 1.

### Piping

Connect piping to valve according to markings on valve body. Apply pipe compound sparingly to male pipe threads only. If applied to valve threads, the compound may enter the valve and cause operational difficulty. Avoid pipe strain by properly supporting and aligning piping. When tightening the pipe, do not use valve or solenoid as a lever. Locate wrenches applied to valve body or piping as close as possible to connection point.

**IMPORTANT:** To protect the solenoid valve, install a strainer or filter, suitable for the service involved, in the inlet side as close to the valve as possible. Clean periodically depending on service conditions. See ASCO Bulletins 8600, 8601, and 8602 for strainers.

## Wiring

Wiring must comply with local codes and the National Electrical Code. The solenoid housing has a 7/8" diameter hole to accommodate 1/2" conduit. On some constructions, a green grounding wire is provided. To facilitate wiring, the solenoid enclosure may be rotated 360° by removing the retaining cap or clip. **WARNING: When metal retaining clip disengages, it will spring upward.** Rotate enclosure to desired position. Then replace retaining cap or clip before operating.

## Solenoid Temperature

Standard catalog valves are supplied with coils designed for continuous duty service. When the solenoid is energized for a long period, the solenoid enclosure becomes hot and can be touched by hand only for an instant. This is a safe operating temperature. Any excessive heating will be indicated by the smoke and odor of burning coil insulation.

## MAINTENANCE

**NOTE:** It is not necessary to remove the valve from the pipeline for repairs.

**WARNING: Turn off electrical power supply and depressurize valve before making repairs.**

### Cleaning

All solenoid valves should be cleaned periodically. The time between cleanings will vary depending on the medium and service conditions. In general, if the current to the coil is correct, sluggish valve operation, excessive noise or leakage will indicate that cleaning is required. Clean valve strainer or filter when cleaning the valve.

### Preventive Maintenance

1. Keep the medium flowing through the valve as free from dirt and foreign material as possible.
2. While in service, the valve should be operated at least once a month to insure proper opening and closing.
3. Depending on the medium and service conditions, periodic inspection of internal valve parts for damage or excessive wear is recommended. Thoroughly clean all parts. Replace worn or damaged parts. However, for best results, replace all parts as supplied with an ASCO Rebuild Kit.

### Causes Of Improper Operation

1. **Faulty Control Circuit:** Check the electrical system by energizing the solenoid. A metallic "click" signifies that the solenoid is operating. Absence of the "click" indicates loss of power supply. Check for loose or blown fuses, open-circuited or grounded coil, broken lead wires or splice connections.
2. **Burned-Out Coil:** Check for open-circuited coil. Replace coil if necessary. Check supply voltage; it must be the same as specified on nameplate.
3. **Low Voltage:** Check voltage across the coil leads. Voltage must be at least 85% of nameplate rating.
4. **Incorrect Pressure:** Check valve pressure. Pressure to valve must be within range specified on nameplate.
5. **Excessive Leakage:** Disassemble valve (see MAINTENANCE) and clean all parts. Replace worn or damaged parts. However, for best results, replace all parts as supplied with an ASCO Rebuild Kit.



### Coil Replacement (Refer to Figure 2.)

**WARNING: Turn off electrical power supply.** Then proceed as follows:

1. Disconnect coil lead wires and green grounding wire if present.
2. Remove retaining cap or clip, nameplate, and housing.  
**WARNING: When metal retaining clip disengages, it will spring upward.**
3. Remove spring washer, insulating washer, grounding wire terminal (if present), and coil from solenoid base sub-assembly. Insulating washers are omitted when a molded coil is used.
4. Reassemble in reverse order of disassembly. Use exploded view provided for identification and placement of parts.

**CAUTION: The solenoid must be fully reassembled because the housing and internal parts complete the magnetic circuit. Place an insulating washer at each end of non-molded coil.**

### Valve Disassembly and Reassembly

**NOTE: For valves with a manual operator (Suffix MO in catalog number) refer to Figure 3. For standard valves refer to Figure 2.**

**WARNING: Depressurize valve and turn off electrical power supply.** Proceed in the following manner:

1. Remove retaining cap or clip and pull the entire solenoid enclosure off the solenoid base sub-assembly. **CAUTION: When metal retaining clip disengages, it will spring upward.**
2. Unscrew the solenoid base sub-assembly and remove bonnet gasket. For valves with a manual operator, unscrew manual operator body and remove stem retainer, manual operator stem sub-assembly, stem gasket, and bonnet gasket.
3. Remove bonnet screws (4), valve bonnet, core spring, core/diaphragm sub-assembly, and body gasket. **CAUTION: Do not damage or distort hanger spring between core/diaphragm sub-assembly.**
4. All parts are now accessible for cleaning or replacement. Replace worn or damaged parts. However, for best results, replace all parts as supplied with an ASCO Rebuild Kit.
5. Reassemble in reverse order of disassembly. Use exploded view provided for identification and placement of parts.
6. Replace body gasket and core/diaphragm sub-assembly, locating the bleed hole in the diaphragm assembly approximately 45° from the valve outlet.
7. Replace valve bonnet and bonnet screws (4). Torque bonnet screws (4) in a crisscross manner to 95 ± 10 inch-pounds (10,7 ± 1,1 newton-meters).
8. Insert core spring in core, wide end of core spring in core first, closed end protruding from top of core.
9. Replace bonnet gasket and solenoid base sub-assembly. Torque solenoid base sub-assembly to 175 ± 25 inch-pounds (19,8 ± 2,8 newton-meters).
10. For valves with a manual operator, replace stem gasket and manual operator stem sub-assembly in manual operator body.
11. Replace stem retainer on manual operator body. Be sure that the captive washer on manual operator stem sub-assembly is on the outside of the stem retainer when assembled.
12. Replace bonnet gasket, manual operator body, bonnet gasket, and solenoid base sub-assembly. Torque manual operator body and solenoid base sub-assembly to 175 ± 25 inch-pounds (19,8 ± 2,8 newton-meters).
13. Replace solenoid enclosure and retaining cap or clip.
14. Restore electrical power and line pressure.
15. After maintenance, operate the valve a few times to be sure of proper opening and closing.

### ASCO REBUILD KITS

Rebuild Kits and Coils are available for ASCO valves. Parts marked with an asterisk (\*) are supplied in Rebuild Kits.

### ORDERING INFORMATION FOR ASCO REBUILD KITS

When Ordering Rebuild Kits or Coils, Specify Valve Catalog Number, Serial Number, Voltage, and Frequency.

### PARTIAL VIEW OF MOUNTING BRACKET (OPTIONAL)

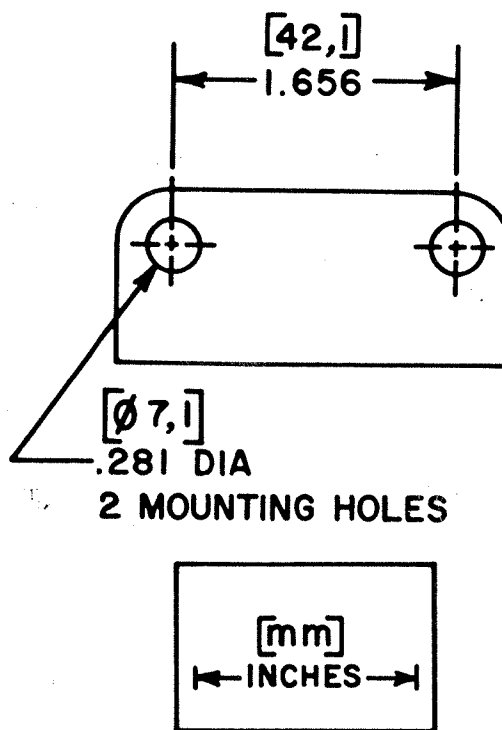
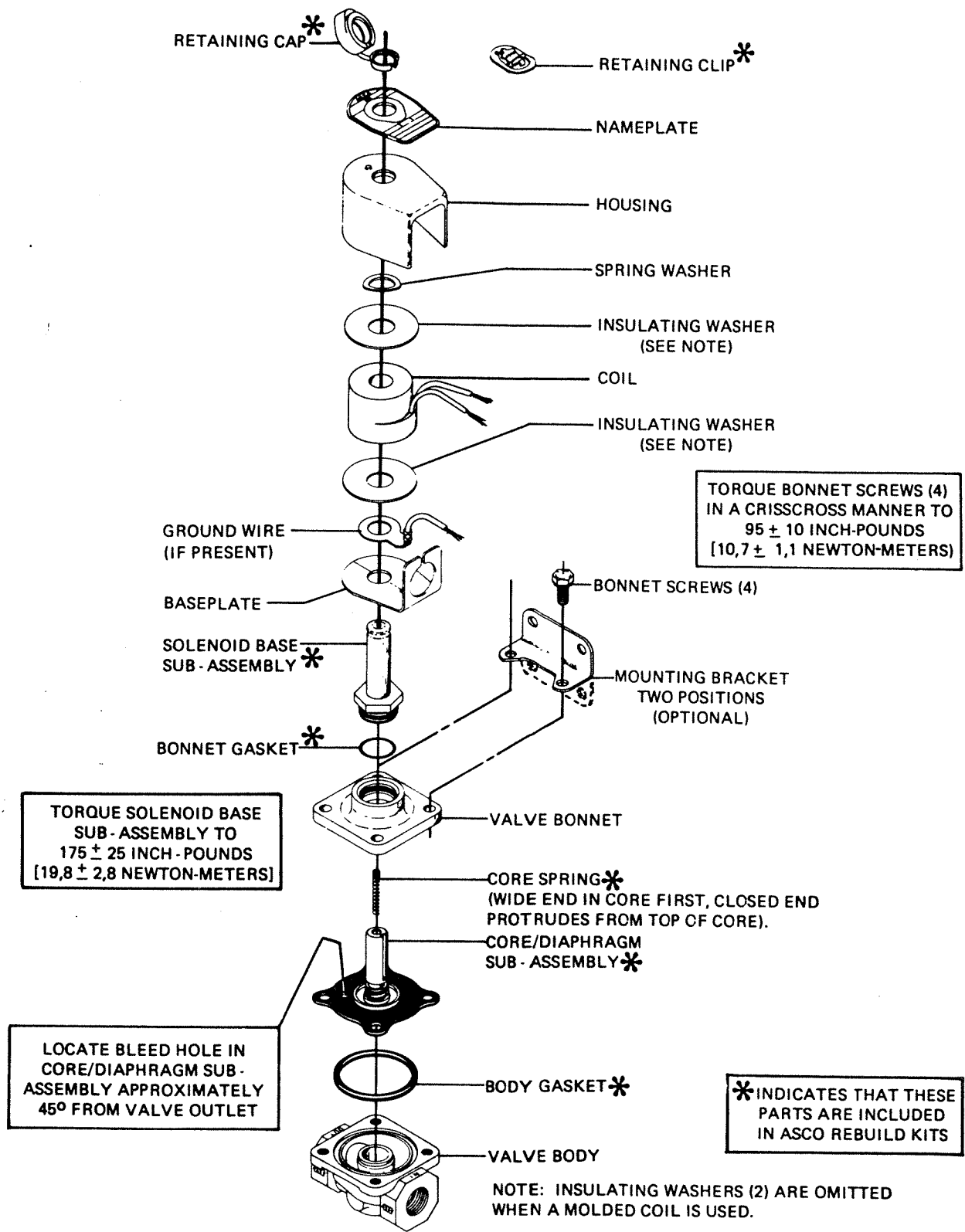
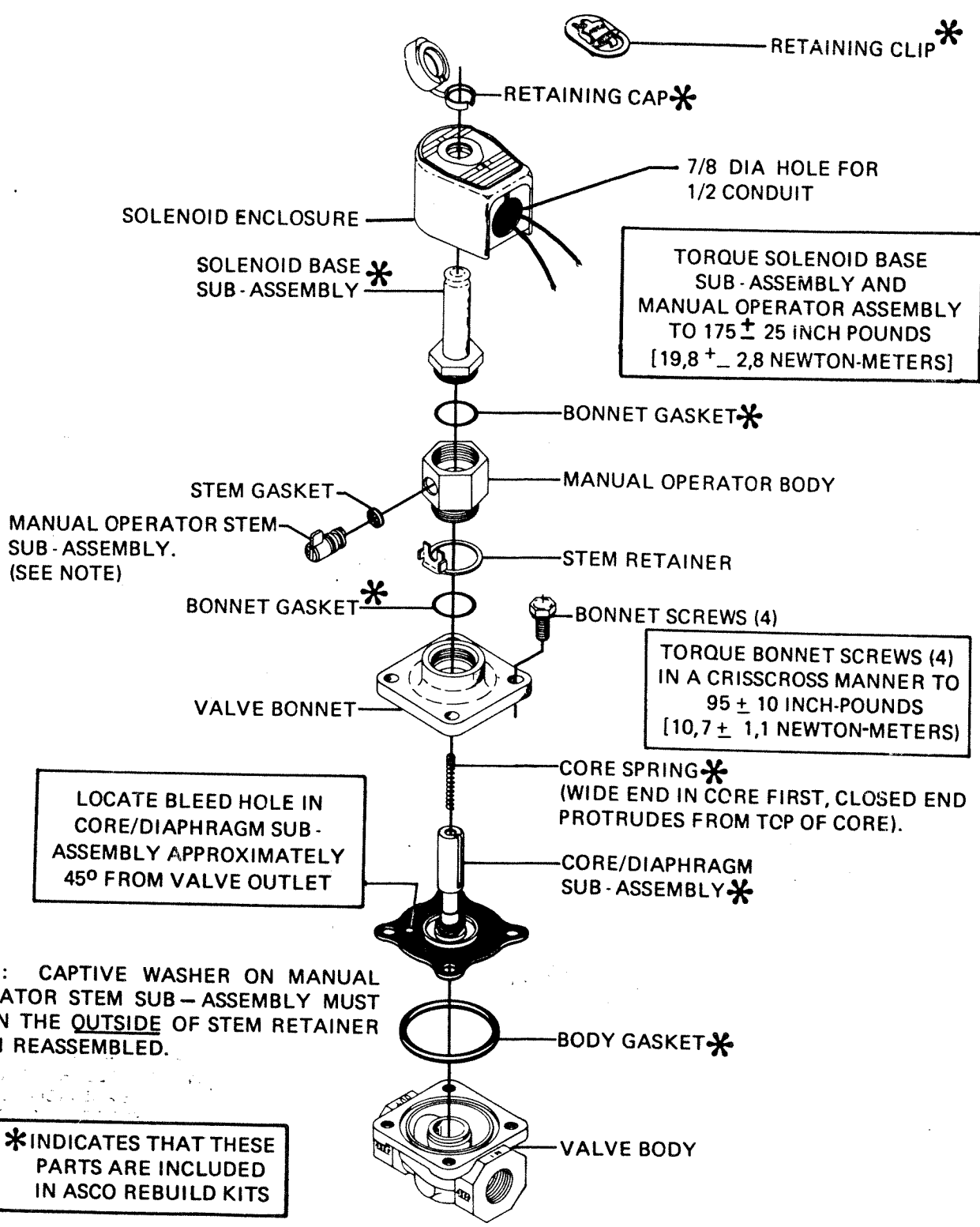

Figure 1.  
Dimensions for Mounting Bracket  
(Optional Feature)



**Figure 2. Bulletin 8210 - 1/2" and 3/4" NPT  
 General purpose solenoid enclosure shown.  
 For watertight and explosion-proof solenoid enclosure used on  
 Bulletin 8211, see Form No. V5380.**



TORQUE SOLENOID BASE SUB-ASSEMBLY AND MANUAL OPERATOR ASSEMBLY TO  $175 \pm 25$  INCH POUNDS [ $19,8 \pm 2,8$  NEWTON-METERS]

TORQUE BONNET SCREWS (4) IN A CRISSCROSS MANNER TO  $95 \pm 10$  INCH-POUNDS [ $10,7 \pm 1,1$  NEWTON-METERS]

LOCATE BLEED HOLE IN CORE/DIAPHRAGM SUB-ASSEMBLY APPROXIMATELY  $45^\circ$  FROM VALVE OUTLET

NOTE: CAPTIVE WASHER ON MANUAL OPERATOR STEM SUB-ASSEMBLY MUST BE ON THE OUTSIDE OF STEM RETAINER WHEN REASSEMBLED.

\*INDICATES THAT THESE PARTS ARE INCLUDED IN ASCO REBUILD KITS

Figure 3. Bulletin 8210 - Manual Operator (Catalog No. with Suffix MO) General purpose solenoid enclosure shown. For watertight and explosion-proof solenoid enclosure used on Bulletin 8211, see Form No. V5380.



**ASCO Valves**

Automatic Switch Co. 50-60 Hanover Road, Florham Park, New Jersey 07932

Form No. V5827R1

**DESCRIPTION**



**MODEL 126 EJECTOR**  
 The Model 126 ejector is a simple tee fitting with a fixed orifice in its inlet port. It provides the proper supply pressure to the main valve diaphragm chamber, allowing various two-way control pilots to control the valve position.

**MODEL 126 EJECTOR DIAGRAM**

Brass Construction / Stainless Steel Construction

MATERIAL	PART NUMBER	P (NPT)	T-TUBE O.D.	STD. ORIFICE	USED ON VALVE SIZES
Brass	213100	3/8"	3/8"	.125"	1 1/4"-6"
Brass	214100	1/2"	1/2"	.188"	8"-10"
Brass	215100	3/4"	3/4"	.188"	12"-16"
316 Stn. Steel	213700	1/4"	3/8"	.090"	1 1/4"-6"
316 Stn. Steel	214700	3/8"	1/2"	.125"	8"-10"
316 Stn. Steel	215700	1/2"	3/4"	.188"	12"-16"

Orifice bushings are stainless steel.

STAINLESS

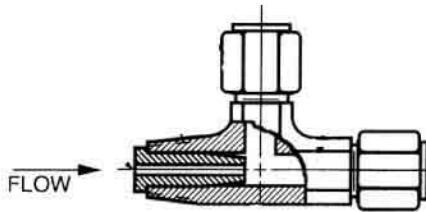

BRASS

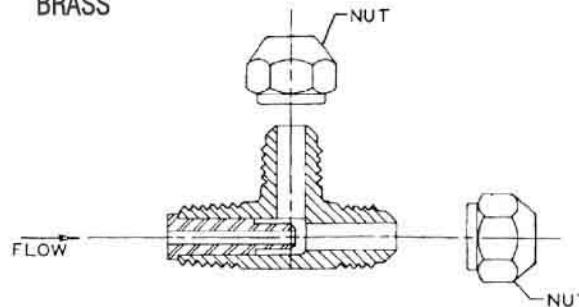

**SCHEMATIC SYMBOL**

The Model 126 Ejector is shown on OCV Valve Schematics as:

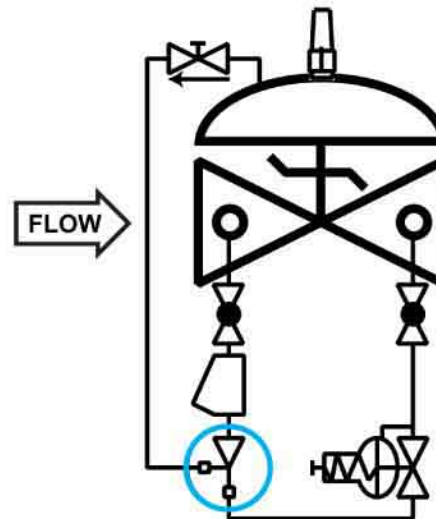
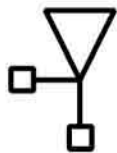

EXAMPLE: Shown here on a MODEL 127-3 Pressure Reducing Valve

## DESCRIPTION

The Model 141-2 Needle Valve is an adjustable restriction device installed in the control circuit tubing. The setting of the needle valve meters the flow into and out of the main valve diaphragm chamber, thus controlling the response speed of the main valve. Depending on the application, the needle valve may be used as a closing speed control, opening speed control, or both simultaneously.



◀ Needle Valves shown  
Sizes: 3/4" & 1/4"

## MODEL 141-2 MATRIX

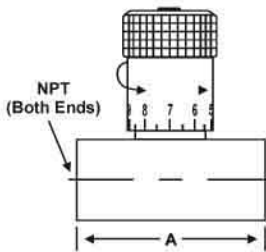

MATERIAL	PART NUMBER	INLET/OUTLET (NPT)	A	USED ON VALVE SIZE*
Brass	683100	1/4	2	1 1/4"-2"
Brass	683101	3/8	2 1/4	2 1/2"-6"
Brass	683102	1/2	2 5/8	8"-10"
Brass	683103	3/4	3 1/4	12"-16"
Stn. Steel	683700	1/4	2	1 1/4"-2"
Stn. Steel	683702	3/8	2 1/4	2 1/2"-6"
Stn. Steel	682704	1/2	2 5/8	8"-10"
Stn. Steel	683703	3/4	3 5/8	12"-16"

Note: Needle valve size may vary on valve application. Consult factory.

## SCHEMATIC SYMBOL

The Model 141-2 Needle Valve is shown on OCV Valve Schematics as:

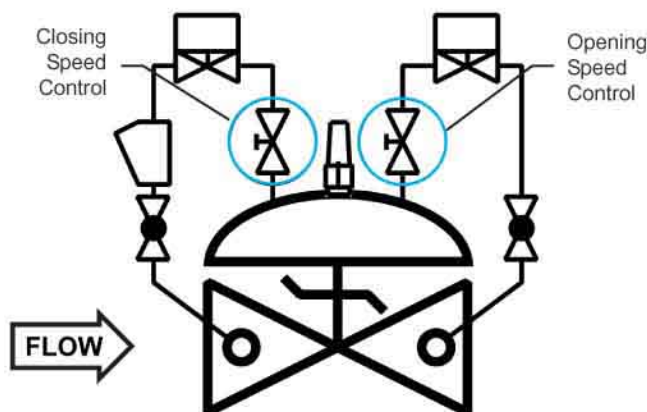
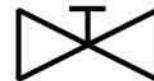

EXAMPLE: Shown here on a MODEL 115-3 DIGITAL VALVE as separate opening and closing speed controls.



**DESCRIPTION**

**MODEL 159 Y-STRAINER**  
 The 159 Y-Strainer installs in the inlet piping of the pilot system and protects the pilot system from solid contaminants in the line fluid. It is the standard strainer for water service valves.

**MODEL 159 Y-STRAINER MATRIX**

MATERIAL	PART NUMBER	INLET/OUTLET (NPT)	BLOW OFF PORT (NP)	A	STD. MESH	USED ON VALVE SIZE
Bronze	660100	3/8	3/8	2 11/16	24	1 1/4"-6"
Bronze	660101	1/2	3/8	2 5/8	24	8"-10"
Bronze	660102	3/4	3/8	3 5/16	24	12"-16"
Stn. Steel	660700	3/8	1/4	2 1/2	20	1 1/4"-6"
Stn. Steel	660701	1/2	1/4	2 1/2	20	8"-10"
Stn. Steel	660702	3/4	1/4	3 1/8	20	12"-16"

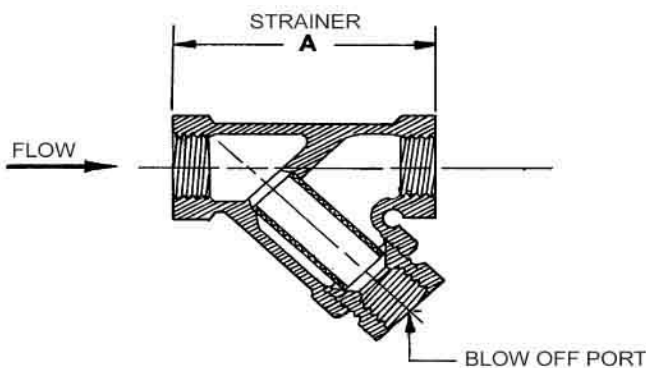

**MATERIALS**

Bronze, ASTM B62  
 Optional mesh sizes: 50, 100  
 Stainless Steel, CF8-M (316)  
 Optional mesh sizes: 60, 80, 100  
 Screens are stainless steel

**SCHEMATIC SYMBOL**

The Model 159 Y-Strainer is shown on OCV Valve Schematics as:

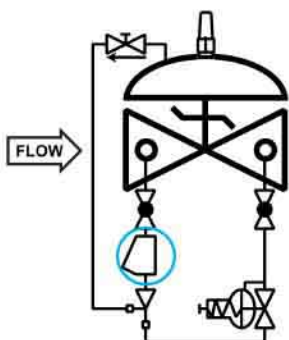

EXAMPLE: Shown here on a MODEL 127-3 Pressure Reducing Valve

**MAINTENANCE**

Routine cleaning and checking of the Y-Strainer will aid in keeping the control valve functioning properly. Pilot system isolation ball valves are supplied on valves equipped with the Model 159 Y-Strainer. These allow flushing of the screen through the blow off port, or removal of the screen itself for manual cleaning.

**DESCRIPTION**

The Model 141-4 Ball Valve is a 1/4-turn shutoff device used for isolating the pilot system from the main valve. They are extremely useful for performing routine maintenance and troubleshooting.

Ball valves are standard on water service valves; optional on fuel service valves.

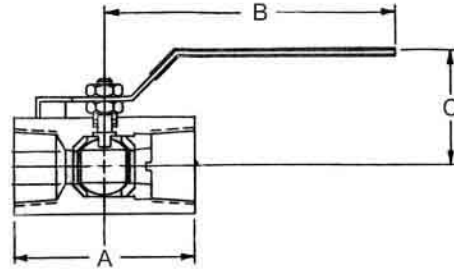

**MODEL 141-4 MATRIX**

MATERIAL	PART NUMBER	INLET/OUTLET (NPT)	A	B	C	USED ON VALVE SIZE*
Bronze	680100	3/8	1 3/4	3 1/2	1 7/8	1 1/4"-6"
Bronze	680101	1/2	2	3 1/2	2 1/4	8"-10"
Bronze	680102	3/4	3	4 3/4	2 1/4	12"-16"
Stn. Steel	680700	3/8	2	3 3/4	2 1/8	1 1/4"-6"
Stn. Steel	680701	1/2	2 1/4	3 3/4	2 1/2	8"-10"
Stn. Steel	680702	3/4	3	4 3/4	2 1/4	12"-16"

**SCHEMATIC SYMBOL**

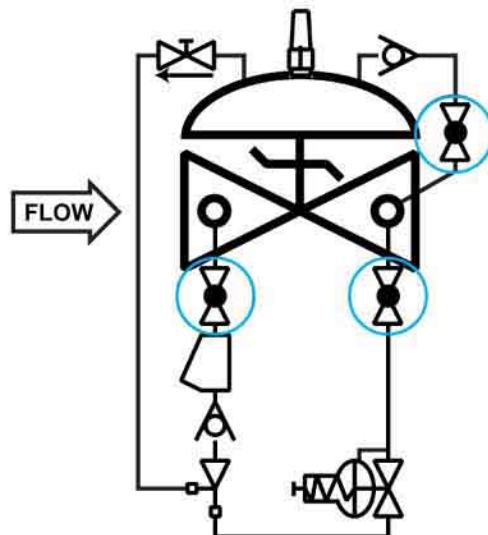

The Model 141-4 Ball Valve is shown on OCV Valve Schematics as:

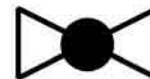

EXAMPLE: Shown here on a MODEL 127-4 Pressure Reducing / Check Valve.