

one-way altitude valve

(sizes 10" - 16")

installation, operating and maintenance instructions

model 3331

GENERAL DESCRIPTION

The OCV Model 3331 is designed to control the level in a storage tank or reservoir without the use of floats or other devices within the tank itself. It is an on-off valve that remains fully opened until the high level shutoff point is reached.

The 3331 is designed to only fill the tank. Water is withdrawn from the tank either through a separate line, or through a simple check valve installed in parallel to the altitude valve.

The 3331 consists of the following components, arranged as shown on the schematic diagram:

1. **Model 65 Basic Valve Assembly**, a hydraulically operated, diaphragm actuated, pilot controlled globe valve that closes with an elastomer-on-metal seal.
2. **Model 3300 Altitude Pilot**, a three-way control pilot that senses the tank head under its diaphragm and balances it against an adjustable spring load. Based on the actual tank head as compared to the set point, the pilot shifts to either vent or pressurize the auxiliary pilots in order to open and close the main valve.
3. **Model 3600 Three-Way Auxiliary Pilot**, that shifts to open the main valve when its diaphragm is chamber is vented by the altitude pilot, and shifts to close the main valve when its diaphragm chamber is pressurized by the altitude pilot.
4. **Model 6401 Two-Way Auxiliary Pilot**, a two way, normally pilot valve that opens when its diaphragm chamber is vented by the altitude pi-

lot, which, in turn, allows the main valve to open.

5. **Model 141-2 Needle Valve** that controls the opening and closing speed of the main valve.
6. **Model 159 Y-Strainer** that protects the pilot system from solid contaminants in the line fluid.
7. Two **Model 141-4 Ball Valves**, useful for isolating various parts of the pilot system for troubleshooting or repair.
8. **Model 155 Visual Indicator** that enables the user to determine the valve's operating position at a glance.

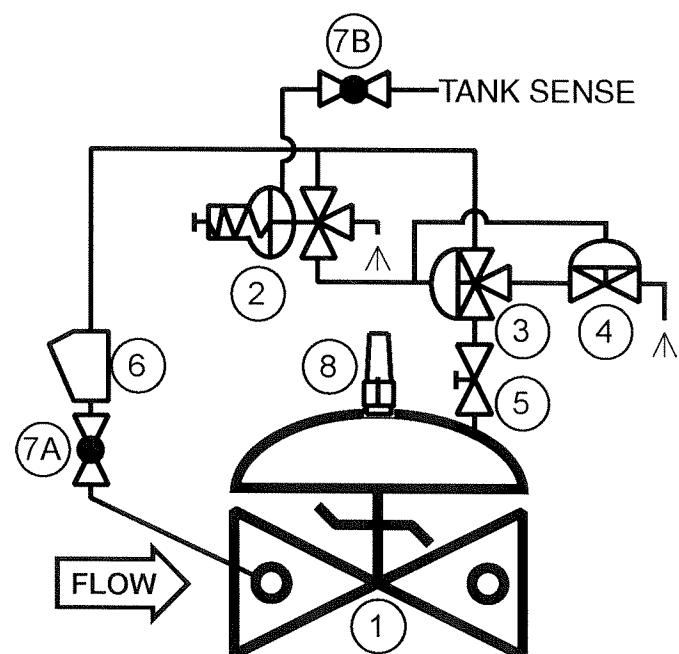

THEORY OF OPERATION

Operation of the 3331 is quite simple and can be readily understood by referring to the schematic diagram.

Tank head is sensed under the diaphragm of the altitude pilot (2) through ball valve (7B). When the head falls below the set point, the pilot shifts to vent the diaphragm chambers of the two auxiliary pilots (2 and 3) to atmosphere. The three-way auxiliary pilot (2) shifts to connect port 1 to port 2 and block port 3. The two-way auxiliary pilot (3) opens. Now the diaphragm chamber of the main valve (1) is allowed to vent to atmosphere and line pressure forces the main valve to the full open position. The tank begins to fill.

When the tank level rises to the high level shutoff point (set point), the altitude pilot shifts to connect inlet pressure to the diaphragm chambers of the auxiliary pilots. Pilot (3) closes, and pilot (2) shifts to connect port 3 and port 1, which, in turn, connects full inlet pressure to the main valve diaphragm chamber, forcing the valve fully and tightly closed.

INSTALLATION

The 3331 valve is furnished fully factory assembled except for the tank sense line. In areas where freezing temperatures are possible, the valve should be located in a vault below the frost line. The flow arrow on the name tag (located on the valve flange) should point *toward* the tank. As a further check, the spring barrel and adjusting screw of the altitude pilot will point *away from* the tank. See the Model 65 Basic Valve section of this manual for full details of valve installation.

Once the main valve is installed, the tank sense line must be connected at ball valve (7B). The proper installation of this sense line is critical to the efficient operation of the altitude valve. The following guidelines apply.

1. It is essential that the sense line be connected as close to the tank as possible in order to accurately sense the tank head. In most cases, the best location is the riser of an elevated tank or the wall of a ground storage tank. If this is not practical, connect the sense line to the fill pipe as

close to the tank as possible. In extreme cases, the sense line may be connected at the discharge body side port of the main valve, but this should only be done if the valve itself is extremely close to the tank.

2. Minimum recommended size for the sense line is ½" OD tubing or 3/8" pipe.
3. In order to prevent air accumulation, the sense line should slope slightly upwards from the valve to the tank.
4. The 3331 vents its diaphragm chamber to atmosphere, the volume varying according to valve size, as shown below. Provision should be made to drain off or otherwise dispose of this water.

10" - 3.0 gal..

14" - 6.5 gal..

12" - 4.0 gal.

16" - 9.6 gal.

STARTUP AND ADJUSTMENT

The following details the full startup procedures for the Model 3331. Certain adjustments may not be necessary if the valve was preset at the factory. Nevertheless, the valve's operation should be closely monitored until the shutoff level is verified.

1. Loosen the jam nut on needle valve (5) and turn the adjusting screw fully **counterclockwise**.
2. Make sure ball valves (7A) and (7B) are open.
3. Open main line isolation valves as necessary to pressurize the valve and allow flow into the tank.
4. If the main valve does not open, turn the adjusting screw of the altitude pilot (2) **clockwise** until it does.
5. Let the tank fill. If the valve closes before the desired shutoff level is reached, repeat Step 4.
6. When the desired shutoff level is reached, turn the adjusting screw of the altitude pilot **counterclockwise** until the valve begins to close.
7. Observe that the valve closes fully. If the valve closes too quickly, slowly turn the adjusting screw of the needle valve (5) **clockwise** until the desired speed is attained. *CAUTION: Do NOT close the needle valve completely. To do so can prevent the valve from operating at all.*

8. Tighten the adjusting screw jam nuts on altitude pilot (2) and needle valve (5).

MAINTENANCE

Required maintenance of the 3331 is minimal. However, the following checks, periodically performed, will do much to keep the valve operating properly and efficiently.

1. Check for chipped or peeling paint.
2. Check for leaks at fittings and around flanges and connections. Tighten as required.
3. Check the screen of the Y-strainer for buildup of solid material. Clean as required. This point is most important, as a clogged strainer can keep the valve from operating properly. On new installations, it is recommended that the strainer be checked every day or two until experience dictates a greater or lesser interval.

TROUBLESHOOTING

In the event of malfunction of the 3331, the following guide should enable the technician to isolate the cause of the problem and take appropriate corrective action.

MAIN VALVE FAILS TO OPEN

1. Make sure the level in the tank is down enough to call for valve opening. The amount of draw-down required is dependent on the spring used in the altitude pilot, hence on the tank height itself. This varies from approximately 2 feet on the lowest tanks, to approximately 6 feet on the highest.
2. Ball valve (7B) closed — Open as required.
3. Needle valve (5) fully closed — Open as required. See Adjustment instructions.
4. Altitude pilot (2) adjusted too far counterclockwise — See Adjustment Instructions.
5. Carefully disconnect the tubing at the bonnet of the three-way auxiliary pilot (3). There should be no pressure on this line.
 - a) If there is pressure coming through the tubing, proceed to Step 6.
 - b) If there is pressure coming from the bonnet

of the three-way auxiliary pilot, its diaphragm may be ruptured. Disassemble pilot and determine cause. See the 3600 Pilot section of this manual.

- c) If there is no pressure, proceed to Step 7.
6. Altitude pilot leaking or mechanism binding — Disassemble pilot and determine cause. See the 3300 Pilot section of this manual.
7. Two-way auxiliary pilot (4) stuck closed — Disassemble pilot and determine cause. See the 6401 section of this manual.
8. Main valve (1) stem binding — Disassemble valve and determine cause. See the Model 65 section of this manual.

MAIN VALVE FAILS TO CLOSE

1. Make sure that high level has been reached.
2. Ball valve (7A) closed — Open as required.
3. Ball valve (7B) closed — Open as required.
4. Strainer (6) clogged — Clean as required.
5. Needle valve (5) closed fully — Open as required. See Adjustment instructions.
6. Altitude pilot (2) adjusted too far clockwise — See Adjustment instructions.
7. Carefully disconnect the tubing at the bonnet of the three-way auxiliary pilot (3). The tubing should be pressurized.
 - a) If there is no pressure coming through the tubing, the problem is in the altitude pilot (2). Disassemble pilot and determine cause. See the 3300 pilot section of this manual.
 - b) If there is pressure coming through the tubing, proceed to Step 8.
8. Stem of three-way auxiliary pilot (3) binding — Disassemble pilot and determine cause. See the 3600 pilot section of this manual.
9. Stem of main valve (1) binding, diaphragm ruptured, or object caught in valve — Disassemble valve and determine cause. See the Model 65 section of this manual.



installation, operating, and maintenance instructions

series 65

basic control valve

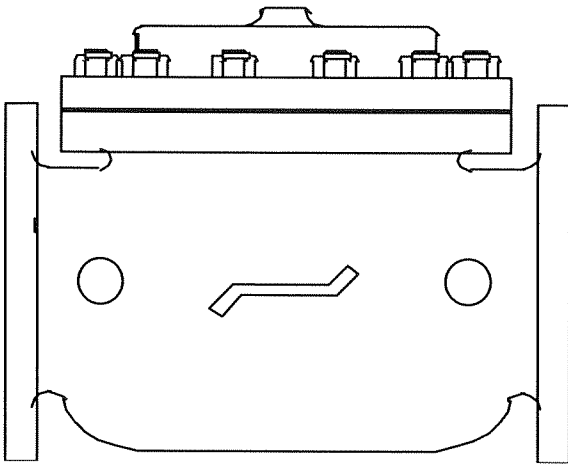

GENERAL DESCRIPTION

The OCV Series 65 is a hydraulically-operated, diaphragm-actuated valve. It is available in either a globe (Model 65) or angle (Model 65A) configuration. The diaphragm is nylon-fabric bonded with synthetic rubber and forms a sealed chamber in the upper portion of the valve, separating operating pressure from line pressure. An elastomeric seat disc forms a tight seal with the valve seat when pressure is applied above the diaphragm.

FUNCTIONAL DESCRIPTION

Because the Series 65 is a hydraulically operated valve, it requires a minimum line pressure of approximately 5 psig in order to function. The valve functions on a simple principle of pressure differential. The line pressure at the inlet of the valve is bypassed through the pilot control piping to the diaphragm chamber of the valve. This pressure, together with the valve spring, works against the pressure under the valve seat. Because the effective area of the diaphragm is greater than that of the seat, the valve is held tightly closed. As the controlling pilot(s) allow the pressure to bleed off the diaphragm chamber, the two opposing pressures begin to balance and the valve will begin to open. The valve can be used to perform a simple on-off function, or with the proper pilot system, a modulating, or regulating function.

In cases where the line fluid is unusually dirty, or is otherwise unsuitable for operating the valve, an independent operating pressure source may be employed. The pressure available from such a source must be equal to, or greater than, line pressure.

INSTALLATION

In order to insure safe, accurate and efficient operation of the OCV control valve, the following list of checkpoints and procedures should be followed when installing the

valve.

1. Make a careful visual inspection of the valve to insure that there has been no damage to the external piping, fittings or controls. Check that all fittings are tight.
2. Thoroughly flush all interconnecting piping of chips, scale and foreign matter prior to mounting the valve.
3. Install the valve in the line according to the flow arrow on the inlet flange. The arrow should point downstream.
4. Allow sufficient room around the valve for ease of adjustment and maintenance service.

In addition, it is highly recommended that:

1. Isolation valves (eg., gate or butterfly) be installed on the inlet and discharge sides of the valve to facilitate isolating the valve for maintenance.
2. Pressure gauges be installed at the inlet and outlet sides of the valve to provide monitoring of the valve during initial start-up and during operation. The body side ports, if unused by the pilot system, provide a convenient connection for the gauges.
3. All valves larger than 6" be installed horizontally, i.e., with the bonnet pointed up, for ease of adjustment and maintenance servicing.

MAINTENANCE

The OCV control valve requires no lubrication and a minimum of maintenance. However, a periodic inspection should be established to determine how the fluid being handled is affecting the efficiency of the valve. In a water system, for example, the fluid velocity as well as the substances occurring in natural waters, such as dissolved minerals and suspended particles, vary in every installation. The effect of these actions or substances must be determined by inspection. It is recommended that an annual inspection, which includes ex-

amination of the valve interior, be conducted. Particular attention should be paid to the elastomeric parts, i.e., the diaphragm and seat disc. Any obviously worn parts should be replaced.

REPAIR PROCEDURES

In the event of malfunction of the OCV control valve, troubleshooting should be conducted according to the procedures outlined for the specific model of valve. Then, if those steps indicate a problem with the main valve, this section will outline the procedures necessary to correct the problem.

Problems with the main valve can be classed in three basic categories:

1. VALVE FAILS TO OPEN
 - a. Diaphragm damaged* - See Procedure A
 - b. Stem binding - See Procedure B
2. VALVE FAILS TO CLOSE
 - a. Diaphragm damaged* - See Procedure A
 - b. Stem binding - See Procedure B
 - c. Object lodged in valve - See Procedure B
3. VALVE OPENS AND CLOSSES BUT LEAKS WHEN CLOSED
 - a. Seat disc damaged - See Procedure C
 - b. Seat ring damaged - See Procedure D

*A diaphragm failure can prevent the valve from either opening or closing, depending on the flow direction. Most water service valves flow "under the seat", in which case a diaphragm failure will keep the valve from closing. On the other hand, most fuel service valves flow "over the seat", in which case a diaphragm failure will keep the valve from opening. To determine which you have, examine the bridge mark cast into the side of the valve body, then compare it with the figures below.

PROCEDURE A : DIAPHRAGM REPLACEMENT

1. Isolate the valve from the system by closing upstream and downstream block valves.
2. Loosen one of the tubing connections on the bonnet. Allow any residual pressure to bleed off.
3. Remove all tubing connected at the bonnet.
4. Remove the bonnet nuts.
5. Remove the bonnet. If the bonnet sticks in place, it may be loosened by rapping sharply around its edge with a rubber-headed mallet. *NOTE: 8" and larger valves are equipped with eye bolts through which a chain can be fastened to aid in*

- lifting the bonnet.*
6. Remove the spring.
 7. Remove the diaphragm plate capscrews and the diaphragm plate.
 8. Remove the old diaphragm.
 9. Making sure the dowel pin holes are in the proper location, place the new diaphragm over the studs and press down until it is flat against the body and spool.
 10. Replace the diaphragm plate and the diaphragm plate capscrews.
 11. Tighten all diaphragm plate capscrews snugly.
 12. Replace the spring.
 13. Replace the bonnet and reinstall the bonnet nuts.
 14. Tighten the bonnet nuts snugly using a criss-cross tightening pattern.
 15. Reinstall the control tubing.
 16. Reopen the upstream and downstream block valves.
 17. Before placing the valve back in service, perform the air bleed procedure described in the first section of this manual.

PROCEDURE B: CORRECTION OF BINDING STEM

1. Perform Steps 1 thru 6 of Procedure A, above.
2. Remove the spool assembly from the valve. *NOTE:*

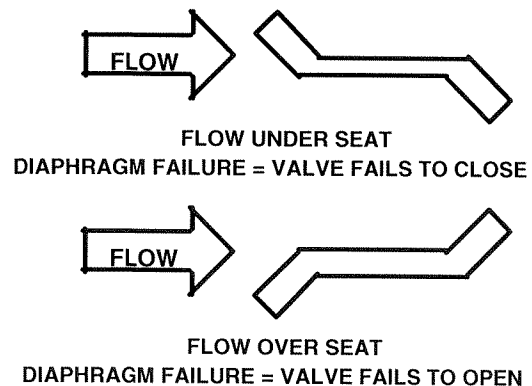

On smaller valves, this can be accomplished simply by grasping the stem and pulling upward. Valves 6" and larger have the top of the stem threaded to accept an eyebolt to aid in lifting the spool out of the body. 6" thru 12" valves are threaded 3/8-16. 14" and 16" valves are threaded 5/8-11.

3. Carefully examine both ends of the stem for deep scratches, scoring or buildup of mineral deposits.

- Polish the stem if necessary using a fine grade of emery cloth.
- 4. Similarly, examine and polish the upper bushing (in the bonnet) and the lower guide (in the seat ring).
- 5. Reinstall the spool assembly.
- 6. Reassemble the valve, following Steps 12 thru 17 in Procedure A.

PROCEDURE C: SEAT DISC REPLACEMENT

- 1. Perform Steps 1 and 2 of Procedure B, above.
- 2. With the spool assembly removed from the body, remove the seat retainer screws.
- 3. Slide the seat retainer off the lower end of the stem.
- 4. Remove the seat disc from its groove in the spool.
NOTE: The seat disc may fit quite tightly in the groove. If necessary, it may be pried out using a thin-bladed screwdriver or similar tool.
- 5. Install the new seat disc in the groove.
- 6. Reinstall the seat retainer and tighten the seat retainer screws.
- 7. Reassemble the valve, following Steps 5 and 6 of Procedure B.

PROCEDURE D: SEAT RING REPLACEMENT

NOTE: It is rare for a seat ring to require replacement. Minor nicks and scratches in the seating surface can usually be smoothed out with emery cloth.

- 1. Perform Steps 1 and 2 of Procedure B, above.
- 2. If you are working on a 4" or smaller valve, follow Steps 3 thru 9, below.
- 3. If you are working on a 6" or larger valve, follow Steps 10 thru 16, below.

- 4. Seat rings in valves 4" and smaller are threaded into the valve body. To remove, you will need a special seat ring tool. You may fabricate one using standard pipe as shown in the sketch below, or one may be purchased from OCV.
- 5. Using the seat ring tool, unthread the seat ring from the body.
- 6. Remove the old o-ring from the counterbore in the body.
- 7. Install the new o-ring in the counterbore.
- 8. Using the seat ring tool, install the new seat ring.
- 9. Reassemble the valve, following Steps 5 & 6 of Procedure B.
- 10. Seat rings in valves 6" and larger are bolted into the body with socket head capscrews. In addition you will note that the seat ring is equipped with additional threaded holes that may be used for "jacking" the seat ring out of the body.
- 11. Remove the socket head capscrews.
- 12. Remove the old seat ring from the body by temporarily installing two or more of the capscrews in the "jacking" holes.
- 13. Install a new o-ring in the groove of the new seat ring. Lubricate the o-ring and outer seat ring wall with Vaseline® or similar lubricant.
- 14. Install the new seat ring in the body, making sure that the capscrew holes line up.
- 15. Replace and tighten all the capscrews.
- 16. Reassemble the valve, following Steps 5 and 6 of Procedure B.

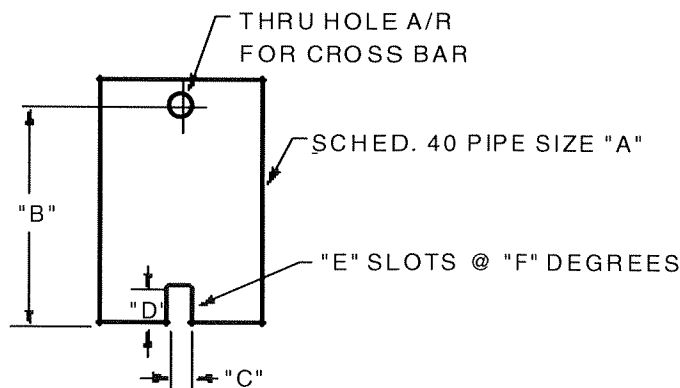

VALVE SIZE	"A" PIPE SIZE	"B" MIN. LENGTH	"C" SLOT WIDTH	"D" SLOT DEPTH	"E" NO. OF SLOTS	"F" SLOT SPACING
1-1/4"	3/4"	6"	3/8"	3/8"	2	180°
1-1/2"	3/4"	6"	3/8"	3/8"	2	180°
2"	1-1/2"	7"	3/8"	3/8"	2	180°
2-1/2"	2"	8"	1/2"	1/2"	3	120°
3"	2-1/2"	9"	5/8"	5/8"	2	180°
4"	3"	10"	5/8"	5/8"	2	180°

REVISED 3-17-97

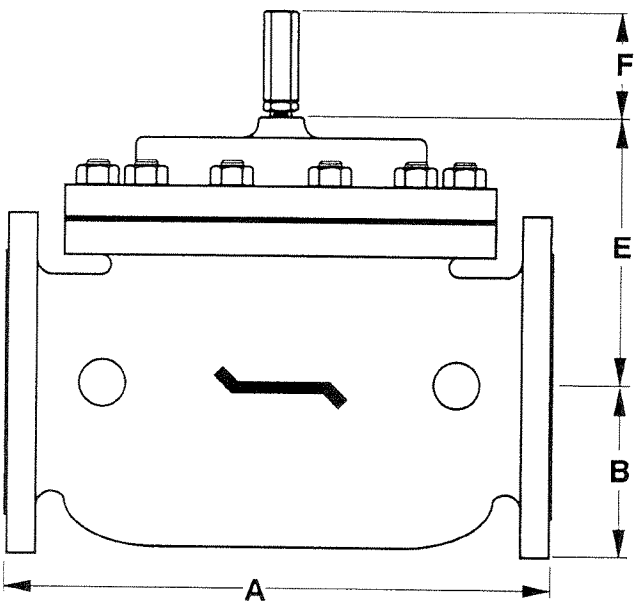
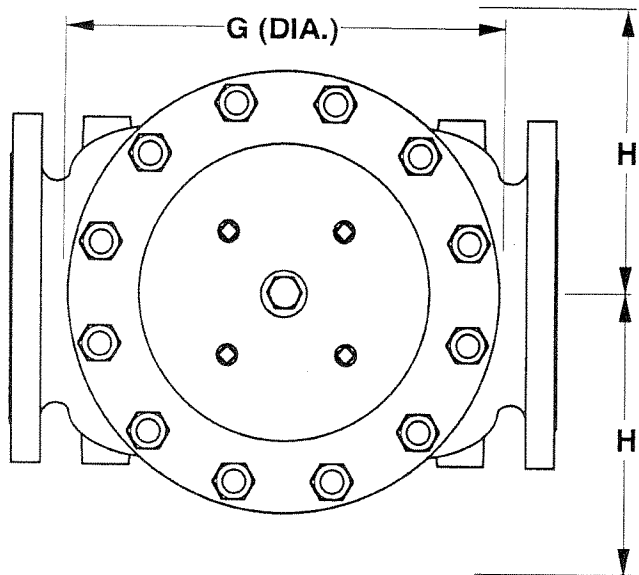

REV. A SDJ 6-6-02
REV. B SDJ 2-3-03

DIM	ANSI CLASS	VALVE SIZE												
		1 1/4	1 1/2	2	2 1/2	3	4	6	8	10	12	14	16	24
A	SE	8.75	8.75	9.88	10.50	13.00	-	-	-	-	-	-	-	-
	150	8.50	8.50	9.38	10.50	12.00	15.00	17.75	25.38	29.75	34.00	39.00	40.38	62.00
	300	8.75	8.75	9.88	11.12	12.75	15.62	18.62	26.38	31.12	35.50	40.50	42.00	63.75
B	SE	1.44	1.44	1.69	1.88	2.25	-	-	-	-	-	-	-	-
	150	2.31	2.50	3.00	3.50	3.75	4.50	5.50	6.75	8.00	9.50	10.62	11.75	16.00
	300	2.62	3.06	3.25	3.75	4.12	5.00	6.25	7.50	8.75	10.25	11.50	12.75	18.00
C	SE	4.38	4.38	4.75	6.00	6.50	-	-	-	-	-	-	-	-
	150	4.25	4.25	4.75	6.00	6.00	7.50	10.00	12.69	14.88	17.00	-	20.81	-
	300	4 3/8	4.38	5.00	6.38	6.38	7.81	10.50	13.19	15.56	17.75	-	21.62	-
D	SE	3.12	3.12	3.88	4.00	4.50	-	-	-	-	-	-	-	-
	150	3.00	3.00	3.88	4.00	4.00	5.50	6.00	8.00	11.38	11.00	-	15.69	-
	300	3.25	3.25	4.12	4.38	4.38	5.81	6.50	8.50	12.06	11.75	-	16.50	-
E	ALL	6.00	6.00	6.00	7.00	6.50	7.92	10.00	11.88	15.38	17.00	18.00	19.00	27.00
F	ALL	3.88	3.88	3.88	3.88	3.88	3.88	3.88	6.38	6.38	6.38	6.38	6.38	8.00
G	ALL	6.00	6.00	6.75	7.69	8.75	11.75	14.00	21.00	24.50	28.00	31.25	34.50	52.00
H	ALL	10.00	10.00	11.00	11.00	11.00	12.00	13.00	14.00	17.00	18.00	20.00	20.00	28.50

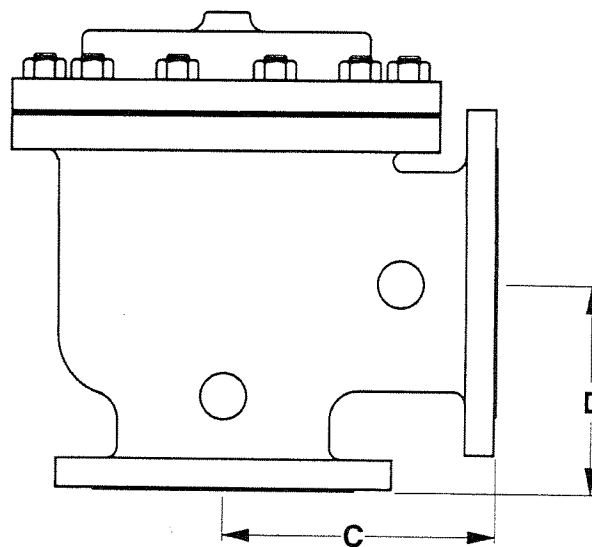

NOTE: 3" VALVE DIMENSIONS ARE FOR NEW MODEL 3100

4" VALVE DIMENSIONS ARE FOR NEW MODEL 4400

TOLERANCES		 OCV Control Valves TULSA, OKLAHOMA U.S.A.	
UNLESS NOTED FRACTIONAL $\pm 1/64$ DECIMAL $\pm .005$ MACH. FINISH 125/ ANGULAR $\pm 1/2^\circ$			
GENERAL VALVE DIMENSIONS			
DRAWN BY SDJ	DATE 10-6-97	SIZE A	DRAWING NUMBER 65D
CHKD. BY	DATE		REV. B

altitude pilot

installation, operating, and maintenance instructions

model 3300

GENERAL DESCRIPTION

The OCV Model 3300 Altitude Pilot is a hydraulically-operated, diaphragm-actuated, three-way pilot valve. Used on a Model 65 Basic Valve, the 3300 is designed to control the level in an elevated tank or reservoir without the use of floats or electrical probes. The use of a large diaphragm area, a long spring and a hydraulically-balanced internal arrangement give this pilot the high sensitivity necessary for this application.

INSTALLATION

The 3300 is normally furnished factory-installed on the main valve; however, it can be field-mounted, either on the valve or remotely, if desired.

These are four connections on the pilot, as shown on the assembly drawing:

1. **3/8" NPT SENSING CONNECTION:** This connection provides the tank head sense to the diaphragm. It is extremely important that this connection be made so as to accurately sense the tank head at all times. The best possible location is the base of the riser itself. For maintenance and troubleshooting purposes, it is advisable that this line contain an isolation cock.
2. **3/8" SUPPLY CONNECTION:** This connection senses inlet (system) pressure to the main valve. Normally it is connected to the inlet side port of the main valve. It should also contain an isolation cock and should be protected by a strainer.

3. **1/2" CONNECTION TO BONNET:** This connection is made directly to the main valve bonnet of 8" and smaller valves. On 10" and larger valves, it is connected to the bonnet of a three-way auxiliary pilot.
4. **3/8" NPT VENT TO ATMOSPHERE:** This is exactly what the name applies—a **free** vent to atmosphere. Depending on the valve size, a certain amount of water will be discharged each time the valve opens, either from this vent or from the auxiliary pilot. Drain provisions should be provided for this water.

VALVE SIZE	AMT. VENTED
1-1/4 & 1-1/2"	2.5 oz.
2"	4.0 oz.
3"	10.0 oz.
4"	1.2 pints
6"	2.0 quarts
8"	1.0 gal.
10"	2.2 gal.
12"	3.5 gal.
14"	6.5 gal.
16"	8.6 gal.

THEORY OF OPERATION

Understanding of the operation of the 3300 will be aided by referring to the assembly drawing. For convenience, the left end of the pilot will be referred to as "up," and the right end as "down."

The pilot is operated by tank head pressure, acting through the sensing connection to the lower side of the

diaphragm (12). There it is balanced by an adjustable spring force acting on the diaphragm assembly. As the tank level falls, the sensed head lessens, allowing the spring (13) to predominate, forcing the diaphragm assembly downwards. On the other hand, as tank level increases, the tank head gradually overcomes the spring, forcing the diaphragm assembly upwards.

Within the valve, there are three “chambers” to consider.

1. The drilled chamber inside the stem (8). This chamber is ported to the supply connection. Note that the stem can form a seal against the seat disc (32). This is referred to as the “inner seal.”
2. The annular chamber between the stem (8) and the seat (7). This chamber is ported to the bonnet connection. Note that the lower end of the seat can also form a seal against the seat disc (32). This is referred to as the “outer seal.”
3. The chamber below the stem and seat. This chamber is ported to the vent.

Now, as the diaphragm assembly moves downward, indicative of a falling tank head, the stem (8) is forced downwards, which first “makes” the inner seal between stem and seat disc (32), then “breaks” the outer seal between seat (7) and seat disc (32). Thus the bonnet chamber is connected to the vent chamber, and the main valve opens.

Conversely, as the diaphragm assembly moves upward, indicative of an increasing tank head, the stem (8) is forced upwards by spring (14) and spring (15). This first “makes” the outer seal between seat (7) and seat disc (32), then “breaks” the inner seal between stem (8) and seat disc (32). Thus the supply chamber is connected to the bonnet chamber, and the main valve closes.

ADJUSTMENT

Initial adjustment of the 3300 is **always** a two-step process:

1. Turn the adjustment screw (17) clockwise until the valve opens. This is indicated by a sudden discharge of water from the vent line. Allow

the tank to fill. If the valve should close prematurely before the tank is full, turn the adjustment screw further clockwise until the valve reopens.

2. When the tank reaches the desired high level, turn the adjustment screw slowly counterclockwise until the valve starts closed. This is best determined by watching for a downward movement of the valve indicator stem.

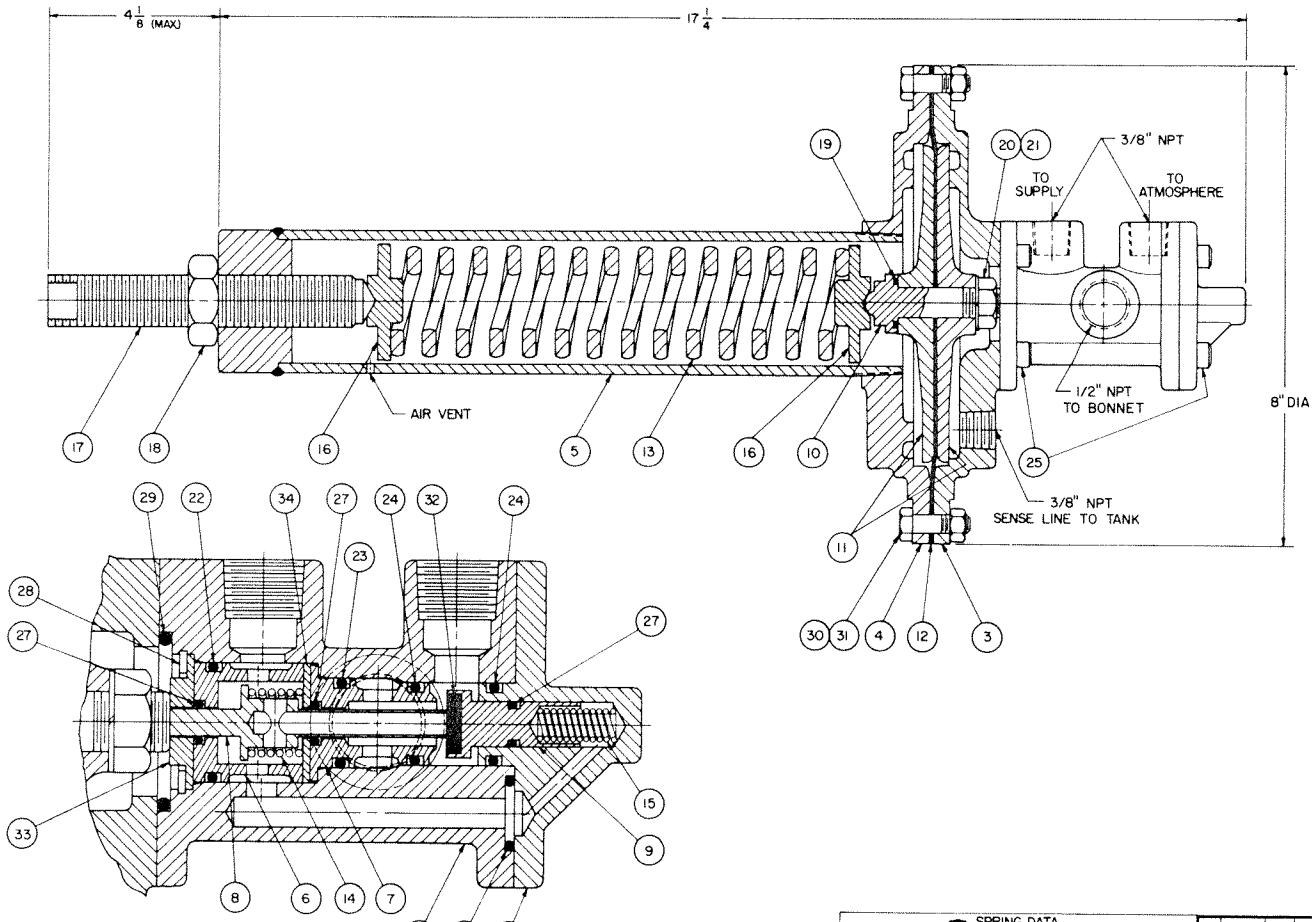

NOTES

1. ▲ = RECOMMENDED SPARE PARTS.
2. WHEN ORDERING PILOTS OR PARTS PLEASE SPECIFY:
 - (A) MODEL NUMBER.
 - (B) WORKING PRESSURE AND TEMPERATURE.
 - (C) HEIGHT OF TOWER OR TANK FROM CENTER LINE OF BASIC VALVE.
 - (D) PART NUMBER.
 - (E) QUANTITY.
 - (F) DESCRIPTION.
 - (G) MATERIAL.

34	300212	SEAL RETAINER, SEAT	1	BRASS
33	300213	SEAL RETAINER, BUSHING	1	BRASS
32	694500	SEAT DISC	1	BUNA-N
31	531725	CAPSCREW	12	STN. STL.
30	590725	HEX NUT	12	STN. STL.
29	60218	O-RING	1	BUNA-N
28	630708	SNAP RING	1	STN. STL.
27	611010	O-RING	3	VITON
26	611111	O-RING	1	VITON
25	530701	CAPSCREW	8	STN. STL.
24	611112	O-RING	2	VITON
23	611113	O-RING	2	VITON
22	610117	O-RING	1	BUNA-N
21	590711	HEX NUT	1	STN. STL.
20	685703	LOCKWASHER	1	STN. STL.
19	610017	O-RING	1	BUNA-N
18	590037	JAM NUT	1	CAD. PL. STL.
17	300048	ADJUSTING SCREW	1	CAD. PL. STL.
16	300049	SPRING RETAINER	2	CAD. PL. STL.
15	651706	SPRING	1	STN. STL.
14	651705	SPRING	1	STN. STL.
13	—	SPRING (SEE DATA)	1	STEEL
12	69400	DIAPHRAGM	1	BUNA-N, NYLON
11	308101	DIAPHRAGM PLATE	1	BRONZE
10	300704	SCREW, DIAPH. PLATE	2	STN. STL.
9	310702	SEAT RETAINER	1	STN. STL.
8	314701	STEM	1	STN. STL.
7	310724	SEAT	1	STN. STL.
6	300211	BUSHING, STEM	1	BRASS
5	300450	SPRING BARREL	1	STEEL
4	304101	BONNET, TOP	1	BRONZE
3	304121	BONNET, BOTTOM	1	BRONZE
2	300135	CAP, BOTTOM	1	BRONZE
1	302101	BODY	1	BRONZE

SPRING DATA			REVISIONS		REF. DWG. NO'S	
PART NO.	TANK HEIGHTS	COLOR CODE	REV.	DATE	BY	
651404	5 TO 30 FEET	BLUE/GOLD				
651405	20 TO 50 FEET	GOLD				
651406	40 TO 80 FEET	BLUE				
651407	70 TO 140 FEET	ORANGE				
651410	130 TO 230 FEET	YELLOW				

ITEM	PART NO.	DESCRIPTION	QTY.	MATERIAL
TOLERANCES UNLESS NOTED OTHERWISE: FINISH: MIL. UNLESS OTHERWISE SPECIFIED.				
DRAWN BY: DATE: 8/84				
SCALE: FULL				
DRAWING NUMBER: 3300				
REV: B				

three-way pilot

installation, operating, and maintenance instructions

model 3600

GENERAL DESCRIPTION

The OCV Model 3600 is a hydraulically-operated, diaphragm-actuated, three-way valve. It is normally used on a main valve when faster-than-normal closing speed is required or when another pilot (e.g., float pilot or solenoid valve) is used to actuate the main valve.

FUNCTIONAL DESCRIPTION

Pressurizing the bonnet of the three-way pilot moves its stem to the "down" position connecting Ports 1 and 3. Depressurizing the bonnet of the OCV Model 3600 allows its stem to return to the "up position," connecting Ports 1 and 2.

Pressurize the bonnet of the 3600 to open the main valve on Model 115-4's, 125's and 119's. De-pressurize the bonnet of the 3600 to open the main valve on Model 3333's and 118's.

TROUBLESHOOTING

A major malfunction in the three-way pilot would generally be evident in a failure of the main valve to open or close. However, keep in mind that such symptoms can also be caused by a malfunction in the main valve itself or in the control pilot(s). If the 3600 is suspected, proceed as follows:

1. FAILURE OF PILOT TO CLOSE MAIN VALVE
 - A. Ruptured diaphragm
 - (1) Detach sense line from the bonnet of the pilot and remove the bonnet. Inspect the

- diaphragm carefully for holes or cracks.
 - (2) If damaged, replace with new diaphragm.

- B. Pilot stem binding
 - (1) With bonnet removed, inspect the stem journal in the bonnet for buildup of foreign material.
 - (2) Clean as necessary and reassemble pilot.
- C. Obstruction in seat area
 - (1) Disassemble pilot and remove obstruction.
- D. Rubber seat damaged
 - (1) Disassemble pilot and examine seats for excessive wear or damage.
 - (2) Replace if necessary and reassemble pilot.

2. FAILURE OF PILOT TO OPEN MAIN VALVE

- A. Pilot stem binding
 - (1) Proceed as in 1B above.
- B. Obstruction in seat area
 - (1) Proceed as in 1C above.
- C. Rubber seat damaged
 - (1) Proceed as in 1D above.

MAINTENANCE

Because of the simplicity of design of the 3600 pilot, required maintenance is minimal. Check fittings and bolts periodically for tightness, and inspect the body for damage or excessive buildup of foreign material.

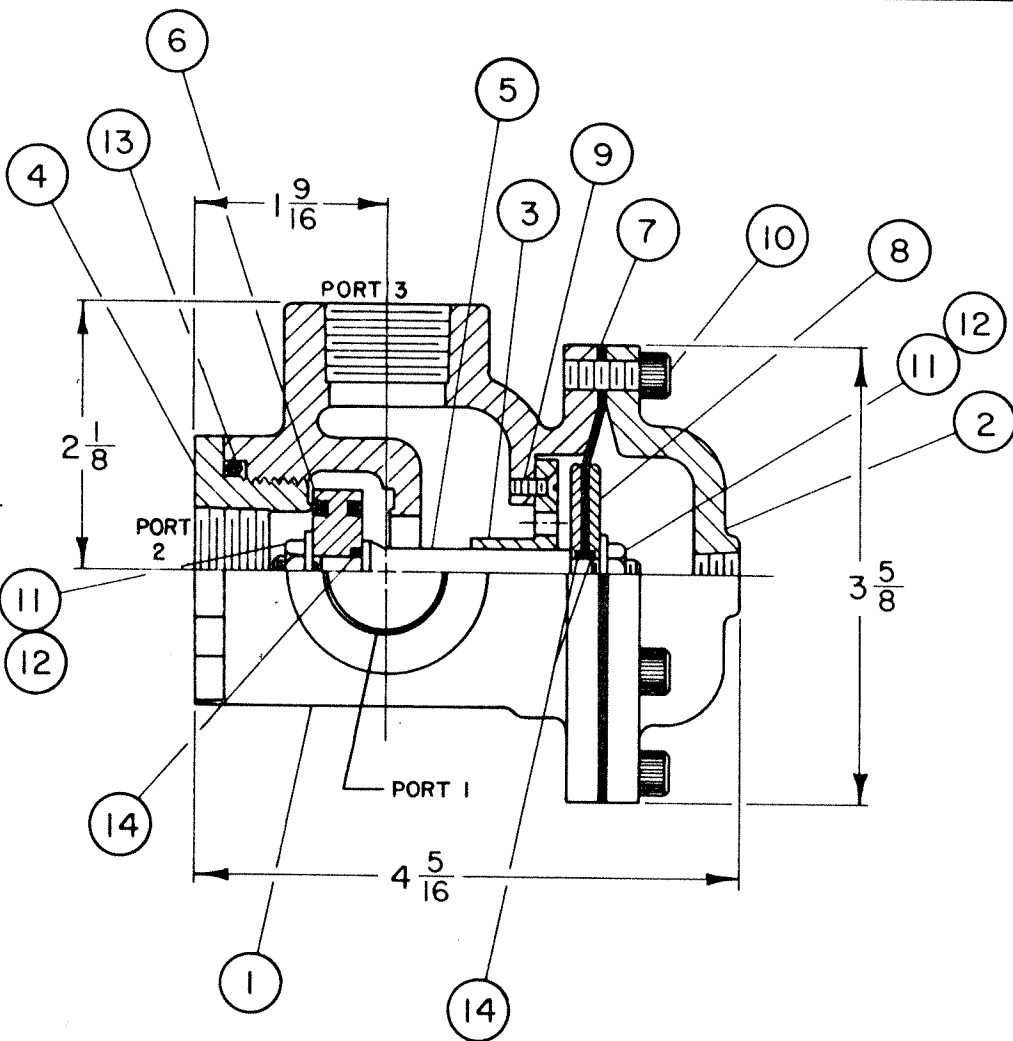

NOTE:

- 1. WHEN ORDERING PARTS, PLEASE SPECIFY; ITEM NO., PART NO. AND MATERIAL.
- 2. ▲ RECOMMENDED SPARE PARTS.

▲	14	611010	3	O-RING	VITON
▲	13	610222	1	O-RING	BUNA-N
	12	685763	2	LOCKWASHER	STAINLESS STEEL
	11	590712	2	HEX HEAD JAM NUT	STAINLESS STEEL
	10	530701	6	SOCKET HD. CAPSCREW	STAINLESS STEEL
	9	532735	2	FLAT HEAD SCREW	STAINLESS STEEL
	8	308135	2	DIAPHRAGM PLATE	BRASS
		308735	2	DIAPHRAGM PLATE	STAINLESS STEEL
▲	7	694035	1	DIAPHRAGM	BUNA-N
		694135	1	DIAPHRAGM	VITON
▲	6	310736	1	SEAT DISC	STN. STL./BUNA-N
		310737	1	SEAT DISC	STN. STL./VITON
	5	314735	1	STEM	STAINLESS STEEL
	4	300171	1	ADAPTER	BRASS
		300771	1	ADAPTER	STAINLESS STEEL
	3	300164	1	GUIDE PLATE	BRASS
		300764	1	GUIDE PLATE	STAINLESS STEEL
	2	304135	1	BONNET	BRONZE
		304735	1	BONNET	STAINLESS STEEL
	1	302135	1	BODY	BRONZE
		302735	1	BODY	STAINLESS STEEL
	ITEM	PART NO.	QTY.	DESCRIPTION	MATERIAL

PARTS LIST

E	D	C	B	A	CHG	E	C	NO	DATE	BY	REF	DWG	NO'S
REVISIONS											REF DWG NO'S		

MATERIAL	TOLERANCES	 TULSA, OKLAHOMA, U.S.A.			
	UNLESS NOTED FRACTIONAL ± 1/64 DECIMAL ± .005 MACH FINISH 125/ ANGULAR ± 1/2°				
NO REQ'D	DRAWN BY B.R.W.	DATE 7-28-83	SIZE	DRAWING NUMBER	REV
SCALE	CHKD BY	DATE	B	3600	

1.15.0.1

NOTE

1. WHEN ORDERING PARTS PLEASE SPECIFY SERIES NUMBER, PART NUMBER AND MATERIAL.
2. ▲ RECOMMENDED SPARE PARTS.
3. ● FURNISHED ASSEMBLED IN OVERHAUL KIT.

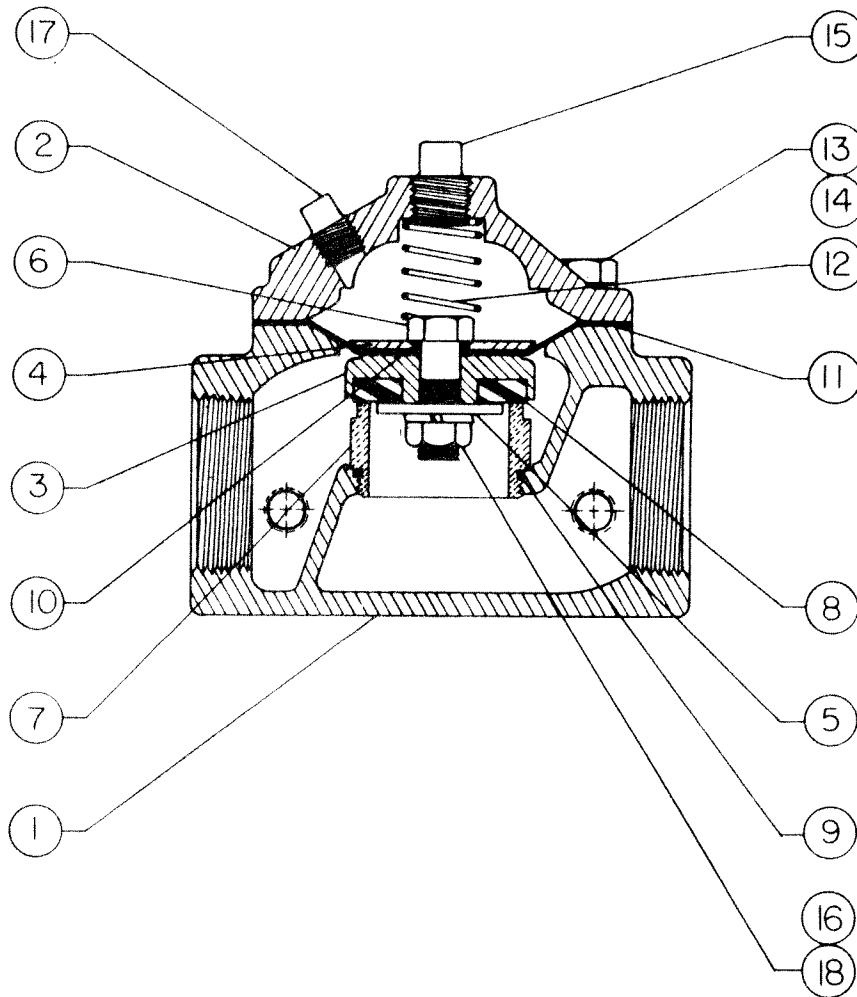

1"			NOMINAL SIZE	
4 1/8"			LENGTH, FACE-TO-FACE	
ITEM	Q.C.V. NO.	QTY.	DESCRIPTION	MATERIAL
●	18 6475	1	STEM NUT	STN. STEEL
●	17 6469	A/R	PIPE PLUG 1/4"	STEEL
●	16 1551	1	LOCK WASHER	STN STEEL
●	15 6471	A/R	PIPE PLUG 3/8"	STEEL
●	14 6457	4	BOLT, CAD. PLATED	STEEL
●	13 6461	4	LOCK WASHER, CAD. PLTD	STEEL
●	12 6445	1	SPRING	STN. STEEL
▲	11 6441	1	DIAPHRAGM	NYLON, BUNA-N
●▲	10 616	1	"O"-RING, STEM	BUNA-N
▲	9 6449	1	"O"-RING, SEAT RING	BUNA-N
●▲	8 6437	1	SEAT DISC	BUNA-N
●	7 6417	1	SEAT RING	RED BRASS
●	6 6433	1	STEM	BRASS
●	5 6425	1	SEAT RETAINER	STN. STEEL
●	4 6421	1	DIAPHRAGM PLATE	BRASS
●	3 6429	1	SEAT CUP	DELTRIN
●	2 6413	1	BONNET	DUCT. IRON
●	1 6407	1	BODY	DUCT. IRON

OCV OIL CAPITAL VALVE CO.
700 East 12th Street / Tulsa, Oklahoma 74106 / 918-927-1042

MODEL 64 BASIC VALVE ASSEMBLY, 1"

ENGINEERING DATA	6401
------------------	------

DESCRIPTION

The Model 141-2 Needle Valve is an adjustable restriction device installed in the control circuit tubing. The setting of the needle valve meters the flow into and out of the main valve diaphragm chamber, thus controlling the response speed of the main valve. Depending on the application, the needle valve may be used as a closing speed control, opening speed control, or both simultaneously.



◀ Needle Valves shown
Sizes: 3/4" & 1/4"

MODEL 141-2 MATRIX

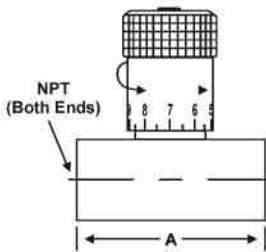

MATERIAL	PART NUMBER	INLET/OUTLET (NPT)	A	USED ON VALVE SIZE*
Brass	683100	1/4	2	1 1/4"-2"
Brass	683101	3/8	2 1/4	2 1/2"-6"
Brass	683102	1/2	2 5/8	8"-10"
Brass	683103	3/4	3 1/4	12"-16"
Stn. Steel	683700	1/4	2	1 1/4"-2"
Stn. Steel	683702	3/8	2 1/4	2 1/2"-6"
Stn. Steel	682704	1/2	2 5/8	8"-10"
Stn. Steel	683703	3/4	3 5/8	12"-16"

Note: Needle valve size may vary on valve application. Consult factory.

SCHEMATIC SYMBOL

The Model 141-2 Needle Valve is shown on OCV Valve Schematics as:

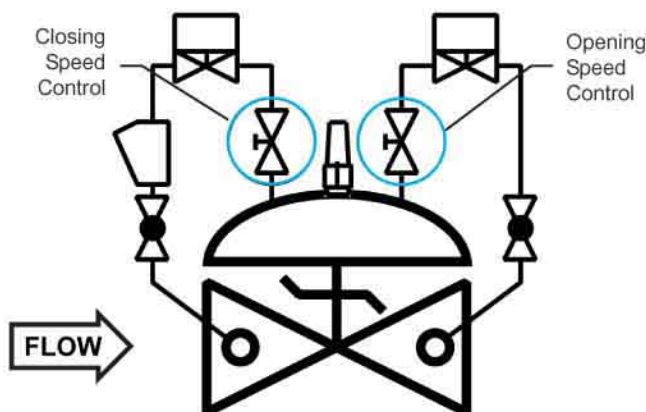
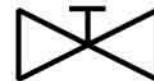

EXAMPLE: Shown here on a MODEL 115-3 DIGITAL VALVE as separate opening and closing speed controls.



DESCRIPTION

MODEL 159 Y-STRAINER

The 159 Y-Strainer installs in the inlet piping of the pilot system and protects the pilot system from solid contaminants in the line fluid. It is the standard strainer for water service valves.

MODEL 159 Y-STRAINER MATRIX

MATERIAL	PART NUMBER	INLET/OUTLET (NPT)	BLOW OFF PORT (NP)	A	STD. MESH	USED ON VALVE SIZE
Bronze	660100	3/8	3/8	2 11/16	24	1 1/4"-6"
Bronze	660101	1/2	3/8	2 5/8	24	8"-10"
Bronze	660102	3/4	3/8	3 5/16	24	12"-16"
Stn. Steel	660700	3/8	1/4	2 1/2	20	1 1/4"-6"
Stn. Steel	660701	1/2	1/4	2 1/2	20	8"-10"
Stn. Steel	660702	3/4	1/4	3 1/8	20	12"-16"

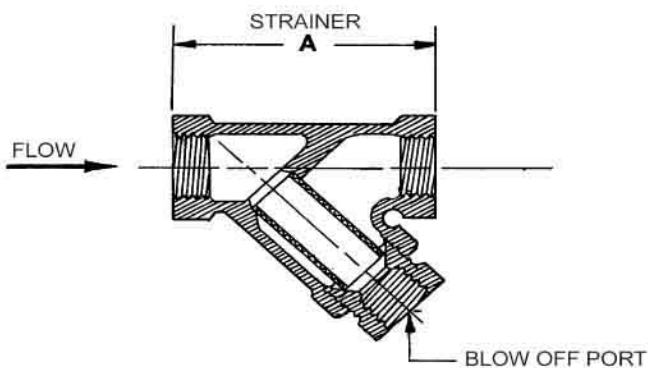

MATERIALS

Bronze, ASTM B62
Optional mesh sizes: 50, 100

Stainless Steel, CF8-M (316)
Optional mesh sizes: 60, 80, 100

Screens are stainless steel

SCHEMATIC SYMBOL

The Model 159 Y-Strainer is shown on OCV Valve Schematics as:

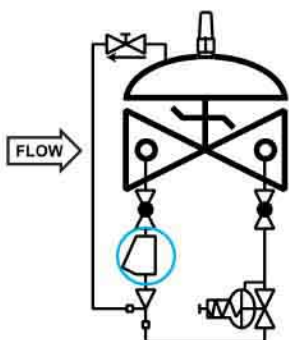

EXAMPLE: Shown here on a MODEL 127-3 Pressure Reducing Valve

MAINTENANCE

Routine cleaning and checking of the Y-Strainer will aid in keeping the control valve functioning properly. Pilot system isolation ball valves are supplied on valves equipped with the Model 159 Y-Strainer. These allow flushing of the screen through the blow off port, or removal of the screen itself for manual cleaning.

DESCRIPTION

The Model 141-4 Ball Valve is a ¼-turn shutoff device used for isolating the pilot system from the main valve. They are extremely useful for performing routine maintenance and troubleshooting.

Ball valves are standard on water service valves; optional on fuel service valves.

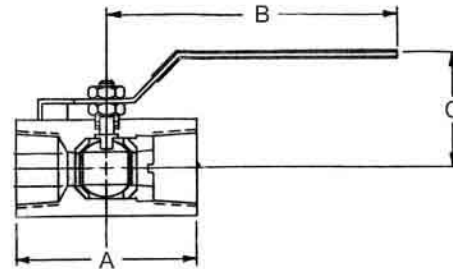

MODEL 141-4 MATRIX

MATERIAL	PART NUMBER	INLET/OUTLET (NPT)	A	B	C	USED ON VALVE SIZE*
Bronze	680100	3/8	1 3/4	3 1/2	1 7/8	1 ¼"-6"
Bronze	680101	1/2	2	3 1/2	2 1/4	8"-10"
Bronze	680102	3/4	3	4 3/4	2 1/4	12"-16"
Stn. Steel	680700	3/8	2	3 3/4	2 1/8	1 ¼"-6"
Stn. Steel	680701	1/2	2 1/4	3 3/4	2 1/2	8"-10"
Stn. Steel	680702	3/4	3	4 3/4	2 1/4	12"-16"

SCHEMATIC SYMBOL

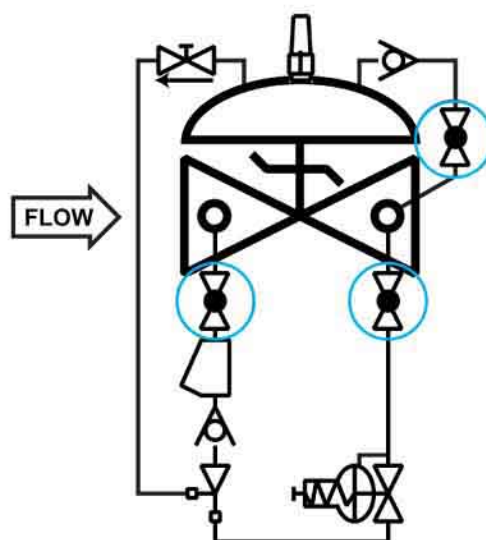

The Model 141-4 Ball Valve is shown on OCV Valve Schematics as:

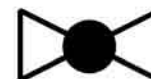

EXAMPLE: Shown here on a MODEL 127-4 Pressure Reducing / Check Valve.

DESCRIPTION

The Model 155 Visual Indicator is a device that enables the user to determine the extent of opening of a control valve. It consists of an adaptor threaded into the center port of the valve bonnet, a rod threaded into the main valve stem, a sealing O-ring, and a protective clear plastic housing. The indicator rod moves as the valve opens and closes. It may be installed on virtually any OCV control valve, and can be done so without any disassembly of the valve itself.

WHERE USED - Standard on Series 94 Check Valves, Series 3330 Altitude Valves, and Series 22 Digital Control Valves. Optional on any other valve not employing a limit switch or position transmitter.



MODEL 155 MATRIX

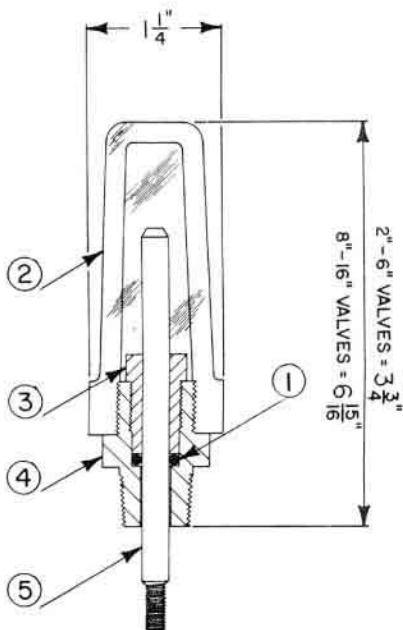

MATERIAL	PART NO. (BRASS ADAPTOR)	PART NO. (STAINLESS ADAPTOR)	VALVE TRAVEL (FULL STROKE)
1 1/4" - 1 1/2"	255100	255700	3/8"
2"	255100	255700	1/2"
2 1/2"	255100	255700	3/4"
3"	255100	255700	1"
4"	255101	255701	1 3/8"
6"	255102	255702	1 1/2"
8" - 10"	255103	255703	2 1/2"
12"	255104	255704	3"
14" - 16"	255105	255705	3 1/2", 4"
24"	255109	255709	6"

ITEM	DESCRIPTION
1	O-Ring
2	Housing
3	Bushing
4	Adaptor
5	Stem

SCHEMATIC SYMBOL

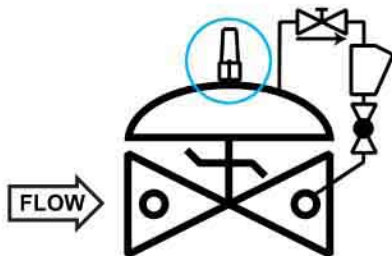

The Model 155 is shown on OCV Valve Schematic as:



EXAMPLE: Shown here on a Model 94-1 Check Valve

MATERIALS

- Indicator Rod: Monel
- Adapter: Brass (std.), Stainless Steel (optional)
- Housing: Butyrate (1 1/4" - 6") Acrylic (8" and larger)
- O-Ring: Viton® (std.) Buna-N, EPDM (optional)

Valve Position Indicator 155