

## DE\PORV\PR

Pneumatically Actuated, Pressure Reducing Deluge Valve

Pneumatically actuated, pilot controlled deluge/pre-action valve, actuated by the pipeline pressure. The valve is closed in its normal, set position and opens when the pneumatic pressure drops in a gas pressurized pilot line, tripping a hydraulic relay. When tripped, the valve regulates to a steady, preset downstream pressure, regardless of upstream pressure or flow rate fluctuations. An emergency manual release valve is fitted as standard.



\* General representation of valve

### CERTIFICATION & COMPLIANCE



- ANSI FCI 70-2 Class VI seat leakage class
- UL listed under VLFT category
- Fire tested to EN ISO 6182-5:2006 (2" - 6" only)
- Lloyd's & ABS approvals

### FEATURES & BENEFITS

- |                                                                                                                                                                                                                                                                                                                                         |                                                                                                                                                                                                                                                                                                                                                                                                                              |
|-----------------------------------------------------------------------------------------------------------------------------------------------------------------------------------------------------------------------------------------------------------------------------------------------------------------------------------------|------------------------------------------------------------------------------------------------------------------------------------------------------------------------------------------------------------------------------------------------------------------------------------------------------------------------------------------------------------------------------------------------------------------------------|
| <ul style="list-style-type: none"> <li>• High pressure (PN25/375psi), high flow deluge systems</li> <li>• Automatic or manual emergency actuation</li> <li>• Hazardous, flammable &amp; explosion classified area fire suppression</li> <li>• Superior design featuring exceptionally low pressure losses at high flow rates</li> </ul> | <ul style="list-style-type: none"> <li>• Low lifelong maintenance costs due to straightforward design</li> <li>• Applicable for fresh water, seawater &amp; foam</li> <li>• Out of box fully assembled &amp; tested valves</li> <li>• Extensive valve &amp; trim materials selection and corrosion protection coating</li> <li>• Factory trimmed for vertical &amp; horizontal installations without modification</li> </ul> |
|-----------------------------------------------------------------------------------------------------------------------------------------------------------------------------------------------------------------------------------------------------------------------------------------------------------------------------------------|------------------------------------------------------------------------------------------------------------------------------------------------------------------------------------------------------------------------------------------------------------------------------------------------------------------------------------------------------------------------------------------------------------------------------|

### TYPICAL APPLICATIONS



Automatic or Manual Actuated Fire Suppression Systems



Petrochemical, Oil & Gas Installations



Tunnels



Power Generation, Transformer & Transmission Plants



Flammable Storage



Hangars & Airport Terminals



Onshore / Offshore



Mining

**OPERATION**

The basic control valve [1] used in this deluge system is a direct sealing elastomeric diaphragm, hydraulically operated control valve engineered specifically for fire protection systems.

In the standby position, the deluge valve is held closed by the upstream water pressure, trapped in the valve's control chamber. The water pressure enters the control chamber through the priming line ball valve [2], a Y-type strainer [3], a check valve [4] and a T-restrictor [5].

Under fire conditions, one (or more) of the automatic sprinklers on the dry (pneumatically pressurized) pilot line burst. The pressure in the relay valve [9] drops, causing it to open and allowing the water to begin to drain from the deluge valve's control chamber through the pressure reducing pilot [10]. The deluge valve opens instantly, regulating to a steady, preset downstream pressure, regardless of upstream pressure or flow rate fluctuations. This allows water to flow into the pipeline and through the open sprinklers over the protected area.

Manual emergency actuation is enabled by opening the emergency manual activation valve [6]. When connected through the pressure reducing pilot (upon request), manual actuation causes the deluge valve to regulate the downstream pressure regardless of upstream pressure or flow rate fluctuations. If unspecified, the manual activation valve drains the water to the atmosphere, allowing the deluge valve to open fully. When actuated, the deluge valve opens instantly and allows water to flow into the pipeline and through the open sprinklers over the protected area.

Standby Position

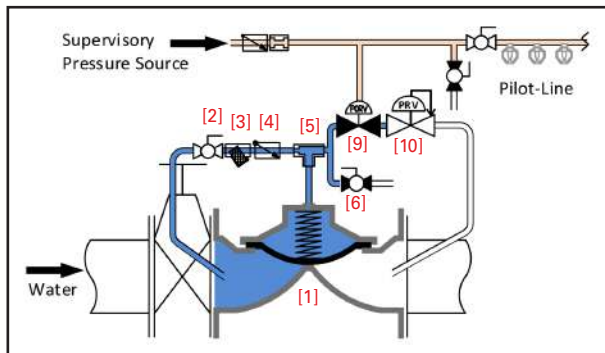

Pneumatically Actuated & Pressure Reducing

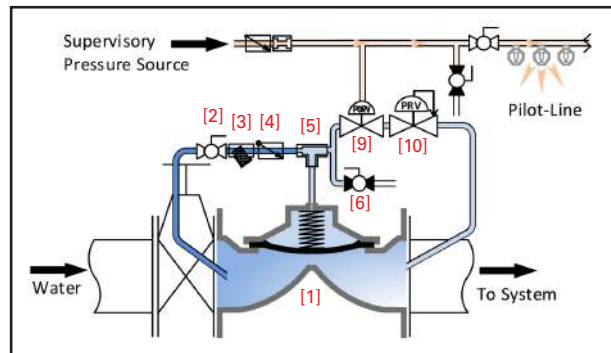

Manually Actuated & Pressure Reducing

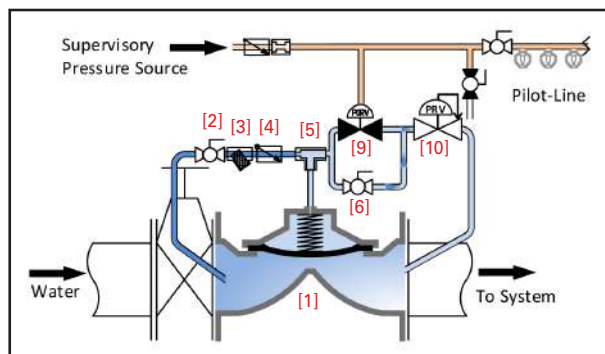

Manually Actuated (Standard)

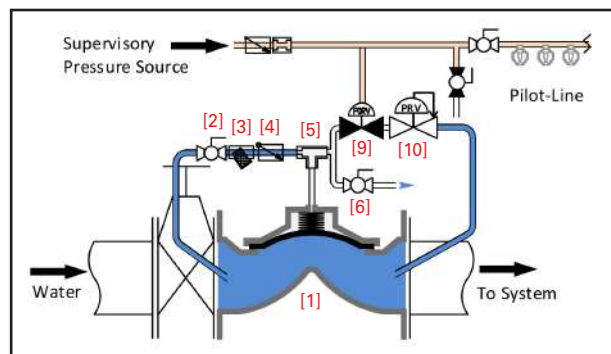

Resetting, maintenance and periodic testing instructions must be followed as described in detail in the applicable OCV IOM (Installation, Operation & Maintenance) Manual.

TYPICAL MATERIALS

ID	Description	Standard	POG <sup>(1)</sup> Applications
1	Valve Body	See Series 100 Engineering Data <sup>(2)</sup>	
2	Ball Valve	Bronze, Stainless Steel Ball	Stainless Steel 316
3	Y-Type Strainer	Bronze, Stainless Steel Screen	Stainless Steel 316
4	Check Valve	Bronze	Stainless Steel 316
5	T Restrictor	Brass	Stainless Steel 316
6	Manual Emergency Valve	Bronze	Stainless Steel 316
7	Drip Valve	Brass	Stainless Steel 316
8	Pressure Gauge	Stainless Steel	Stainless Steel 316
9	66-2UL Relay	Brass	Stainless Steel 316
10	CXPR Pressure Reducing Pilot	Brass, Stainless Steel 316 Seat	Stainless Steel 316

(1) Petrochemical, Oil & Gas

(2) Refer to materials selection guidelines, Engineering Data - Materials: Ductile Iron A-536 65-45-12; Cast Steel A-216 WCB; Cast Steel A-352 LCB; Austenitic Stainless Steel A-351/CF8M; Super Duplex 2507; Nickel-Aluminum-Bronze B-148 UNS C95800

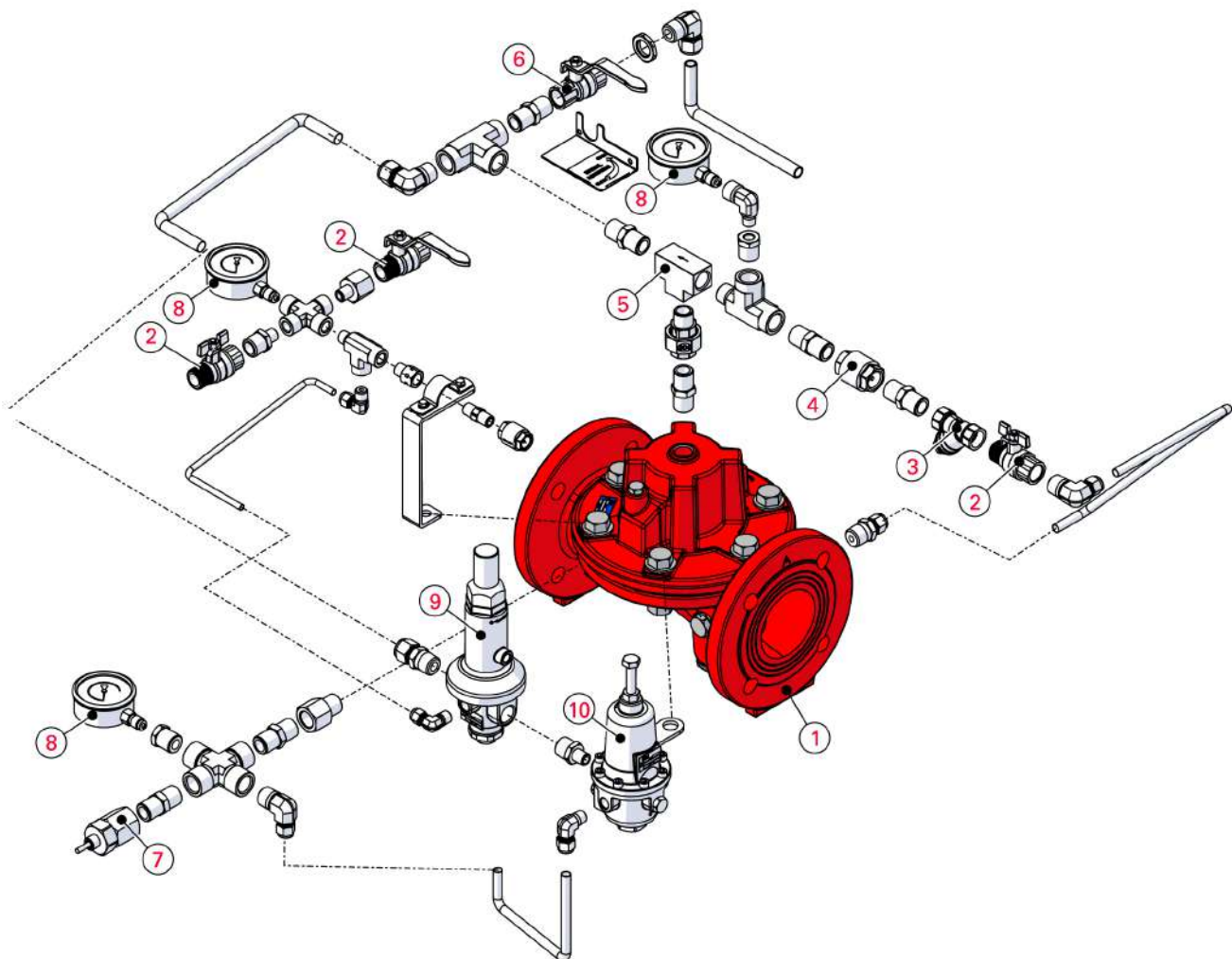

\* General representation of valve

**GENERAL ARRANGEMENT & DIMENSIONS**

Valve	2" (50)		2.5" (65)		3" (80)		4" (100)		6" (150)		8" (200)		10" (250)	
	inch	mm	inch	mm	inch	mm	inch	mm	inch	mm	inch	mm	inch	mm
A	9 5/8	243	9 3/16	233	12 3/16	310	14	356	17 3/16	436	20 7/8	530	25	635
A <sub>G</sub> <sup>(1)</sup>	9 5/8	243	10	253	13 3/16	336	15	380	17 5/16	440	21 7/8	556	N/A	
B	12 5/16	311	12 5/16	311	12 5/16	311	12 5/16	311	12 5/16	311	12 5/16	311	12 1/2	318
C	9 5/8	244	9 5/8	244	9 5/8	244	9 5/8	244	9 5/8	244	10 3/8	265	12 1/2	318
D	10 3/8	264	10 3/8	264	10 7/8	277	11 5/16	288	12 5/8	320	13 5/16	338	14 5/16	364
E	6 11/16	170	6 11/16	170	7 3/16	183	7 5/8	194	8 7/8	226	9 5/8	244	10 5/8	270
F	3 5/16	85	3 5/16	92 1/2	4 1/8	105	14	120	5 7/8	150	7 1/8	180	8 1/2	215
G	10 5/8	268	9 3/16	233	12 3/16	324	12 5/16	324	16 1/8	409	18 5/8	472	19 1/2	494

\* Approximate dimensions

\* (1) Grooved model length

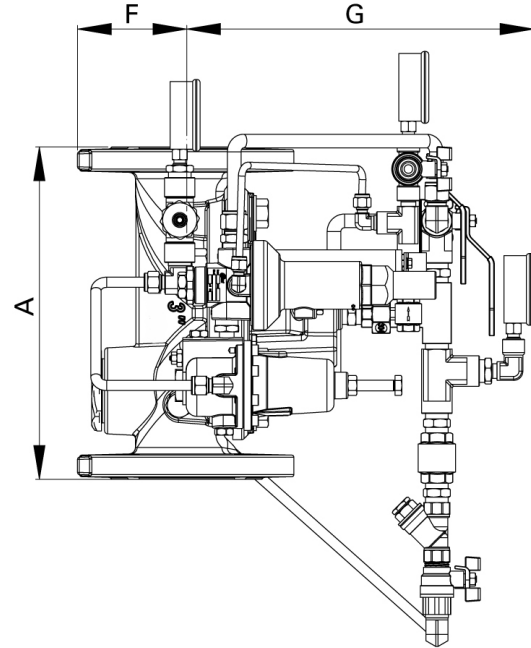
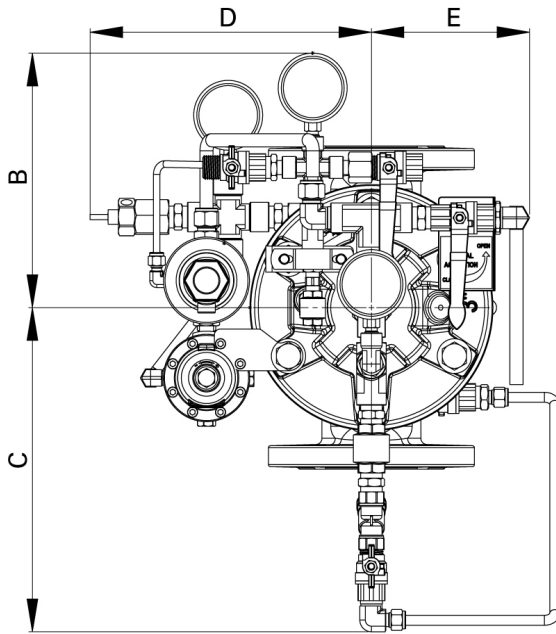

\* General representation of valve

TYPICAL INSTALLATION

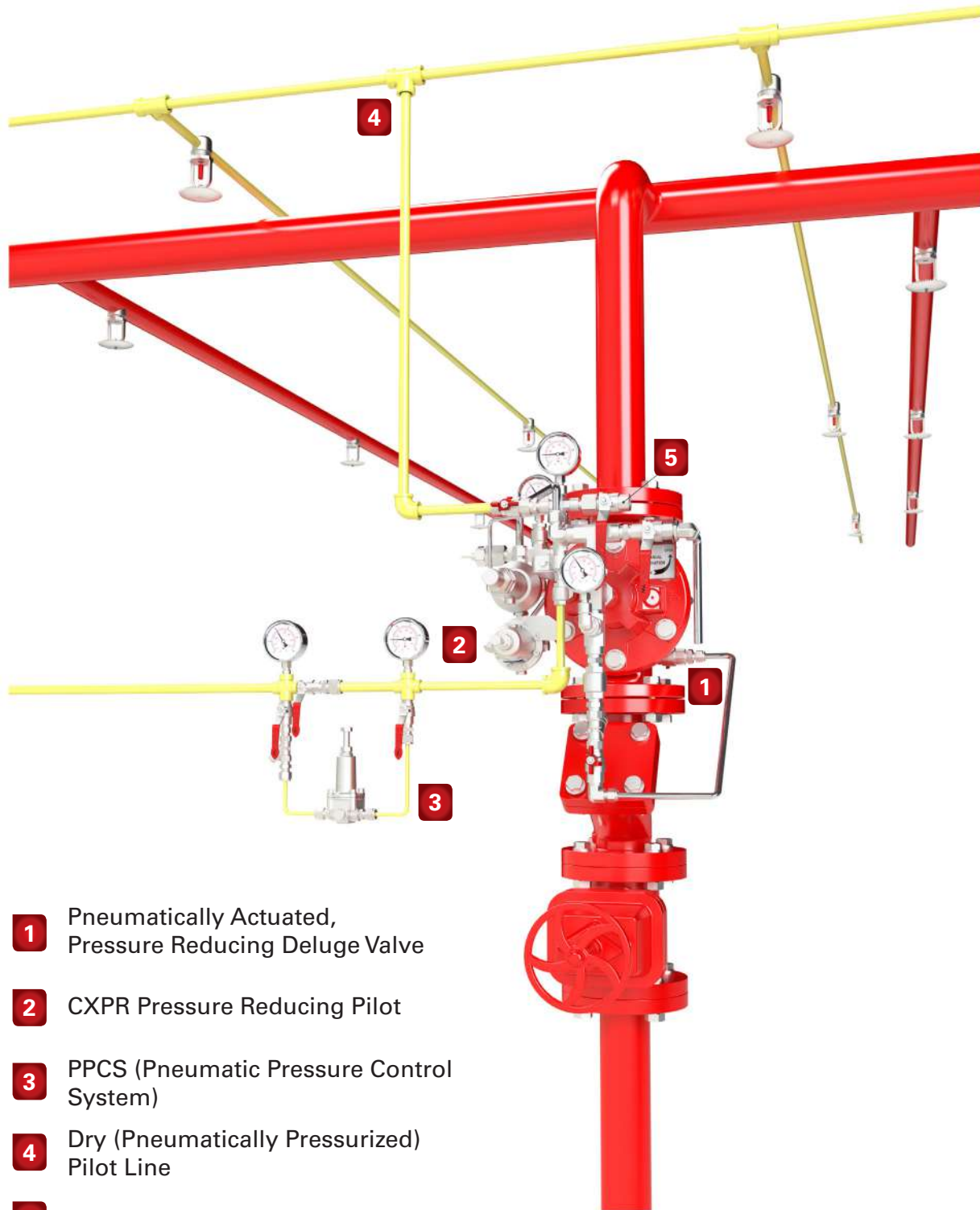

- 1** Pneumatically Actuated, Pressure Reducing Deluge Valve
- 2** CXPR Pressure Reducing Pilot
- 3** PPCS (Pneumatic Pressure Control System)
- 4** Dry (Pneumatically Pressurized) Pilot Line
- 5** Pilot Line - Test Ball Valve

\* Not all items pictured reflect products sold by OCV

## TECHNICAL DATA

**Temperature:**

- Media up to 80°C = 176°F
- Elastomers suitable for extreme climates available upon request

**Sizes:**

- UL listed sizes: Model 68: 2" -10"
- Straight Flow: 2" -24"

**End Connections:**

- Flanged:  
ISO-PN16 & ISO-PN25  
ANSI B16.42 & B16.5 Class #150 and #300  
Additional options available upon request
- Grooved:  
Sizes: 2"-8"

**Pressure Rating:**

- 250 psi for Class #150
- 375 psi for Class #300

**Body and Cover Material:**

- Ductile Iron
- Cast Steel
- Stainless Steel
- NAB

**Trim Material:**

- Bronze/Brass - Copper
- Stainless Steel
- Monel

**Optional Components:**

- Position Indicator
- Pressure Switch
- Alarm Test Trim
- Upstream Drain Valve
- Limit/Proximity Switch
- Explosion Proof

**Items to Specify:**

- Electrical features other than standard (24VDC, IP65/NEMA4)
- If explosion proof accessories are required such as solenoids, pressure switches, etc., please define classification
- Control trim material other than standard
- Required standards, certifications and approvals

## ENGINEERING SPECIFICATIONS

The deluge valve shall be hydraulically operated, direct elastomeric diaphragm-seal, single chamber weir type. The valve shall consist of three major components: the body, the cover and the diaphragm assembly. The diaphragm assembly shall be the only moving part. The diaphragm forms a sealed control chamber in the upper portion of the valve, separating operating pressure from line pressure. Packing glands, stuffing boxes and dynamic O-ring seals are not permitted and there shall not be shafts, discs, bearings or pistons operating the valve. No hourglass shaped disc retainers shall be permitted, and no V-type, U-type or other slotted type disc guides shall be used. The valve shall contain a nylon reinforced rubber diaphragm, elastic & resilient through its entire surface without vulcanized radial seals and/or reinforcements. The diaphragm assembly shall not be guided by any shafts or bearings and shall not be in close contact with other valve parts except for its sealing surface. The deluge valve shall be fully trimmed, hydrostatically and operationally tested at the factory. Maintenance, disassembly and reassembly of all the valve's components shall be made possible on-site and in-line, without the need to remove the valve from the line. Main valve body and bonnet standard material shall be Ductile Iron or Cast Steel. Main valve body and bonnet surfaces shall include a fire red epoxy coating. Other materials and coatings available upon request. The deluge valve shall be a Model 68 DE\POR\PR, UL Listed under VLFT category, as manufactured by OCV Fluid Solutions, Tulsa, OK, USA.

OCV companies worldwide reserve the right to make changes without notice including product specification and configuration, content, description(s), dimensions etc. The information herein is subject to change without notice. OCV shall not be held liable for any errors. All rights reserved. © Copyright by OCV.