

Deluge Pressure Reducing Valves



General representation



Fire Protection

Pressure Reducing, Pneumatically Actuated, Manual Reset Deluge Valve

Description

The OCV 68F DE\PTMR\PRF is a pneumatically actuated, pilot controlled deluge/pre-action valve, actuated by the pipeline pressure. The valve is closed in its normal, set position and opens when the pneumatic pressure drops in a gas pressurized pilot line, tripping a hydraulic relay. When tripped, the valve regulates to a steady, preset downstream pressure, regardless of upstream pressure or flow rate fluctuations. The valve must be manually reset following automatic actuation. An emergency manual release valve is fitted as standard.

Features & Benefits

- High pressure (PN25/375psi), high flow deluge systems
- Automatic or local manual emergency actuation
- Hazardous, flammable & explosion classified area fire suppression
- Superior design featuring exceptionally low pressure losses at high flow rates
- Low lifelong maintenance costs due to straightforward design
- Applicable for fresh or brackish water, seawater & foam
- Out of box fully assembled & tested valves
- Factory trimmed for vertical & horizontal installations without modification
- Extensive valve & trim materials selection and corrosion protection coating

Certification & Compliance

FM Approved



Typical Applications

Automatic or Manual Actuated Fire Suppression Systems

Petrochemical, Oil & Gas Installations

Tunnels

Power Generation, Transformer & Transmission Plants



Flammable Storage

Hangers & Airport Terminals

Onshore/Offshore

Mining



Deluge Pressure Reducing Valves

Operation

The basic control valve [1] used in this deluge system is a direct sealing elastomeric diaphragm, hydraulically operated control valve engineered specifically for fire protection systems.

"Set" condition:

In the "set" condition, the deluge valve is held closed drip tight by the upstream water pressure, trapped in the valve's control chamber. The water pressure enters the control chamber through the priming line ball valve [2], a Y-type strainer [3], a check valve [4] and a T-restrictor [5].

"Fire" conditions and deluge valve actuation:

1. The deluge valve is actuated when pressure in the dry (pneumatically-pressurized) pilot line drops.
2. In case of failure of the automatic actuation system, manual emergency actuation is possible.
3. Deluge valve actuation causes the PTMR (Pneumatic Touch Manual Reset) latching relay [8] to latch open, allowing the water to drain from the RCL 28-2UL relay control chamber (manual-reset latching relay) [7] and the pressure drop causes water to begin to drain from the deluge valve's control chamber through the pressure reducing pilot [9]. Once actuated, the valve must be manually reset by momentarily pressing the PTMR's latching relay [8] reset port.
4. The deluge valve opens instantly, regulating to a steady, preset downstream pressure, regardless of upstream pressure or flow rate fluctuations. This allows water to flow into the pipeline and through the open sprinklers over the protected area.

Manual emergency actuation:

The manual emergency actuation valve [10] may be located inside a metal box or over a panel. If in a box – first lift the cover - and turn the handle.

Closing the deluge valve is possible only after:

1. Shutting the isolation valve [11] (If the priming line is connected to the upstream of the isolation valve).
2. Restoring pressure in the dry (pneumatically-pressurized) pilot line.
3. Verifying the manual emergency actuation valve is closed.
4. Manually resetting by momentarily pressing the PTMR's reset port.

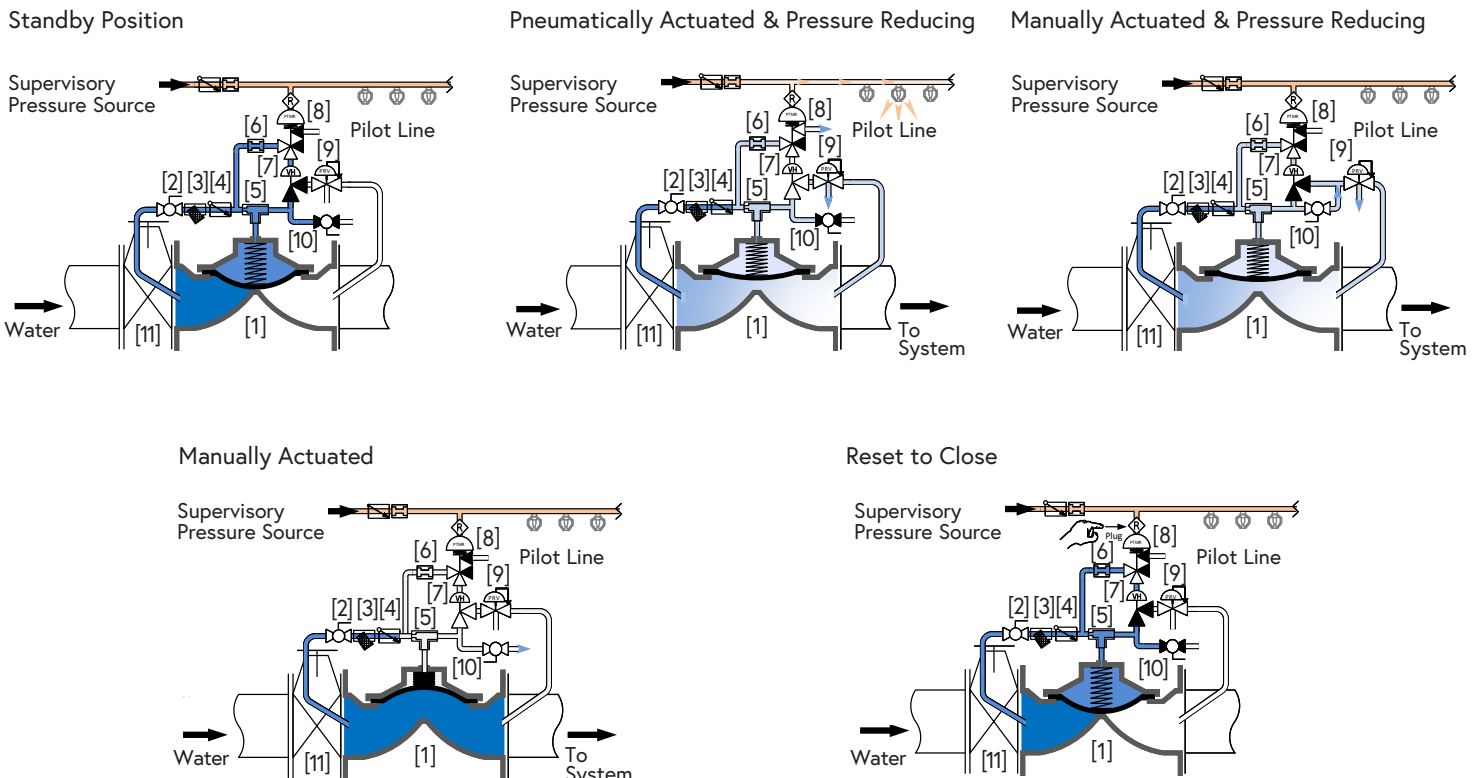

Resetting, maintenance, and periodic testing instructions must be followed as described in detail in the applicable OCV IOM (Installation, Operation & Maintenance) Manual.

Components & Typical Materials

The OCV 68F DE\PTMR\PRF consists of the following components, arranged as shown on the schematic diagram below.

ID	Part	Standard Material	Material per request
1	Valve Body	See OCV S100-68F Engineering Data ⁽¹⁾	
2	Ball Valve	Bronze, Stainless Steel Ball	Stainless Steel, Monel, NAB
3	Y-Type Strainer	Bronze, Stainless Steel Screen	Stainless Steel, Monel, NAB
4	Check Valve	Bronze	Stainless Steel, Monel, NAB
5	T Restrictor	Brass	Stainless Steel, Monel, NAB
6	Restrictor Nozzle	Brass	Stainless Steel, Monel, NAB
7	Manual Emergency Valve	Bronze	Stainless Steel, Monel, NAB
8	Drip Valve	Brass	Stainless Steel, Monel, NAB
9	Pressure Gauge	Stainless Steel	Stainless Steel, Monel, NAB
10	PTMR (Pneumatic Touch Manual Reset)	Brass	Stainless Steel, Monel, NAB
11	28-200 Relay	Brass	Stainless Steel, Monel, NAB
12	PRF (Pressure Reducing Pilot)	Brass	Stainless Steel, Monel, NAB

(1) Refer to materials selection guidelines, Engineering Data - Materials: Ductile Iron A-536 65-45-12; Cast Steel A-216 WCB; Cast Steel A-352 LCB; Austenitic

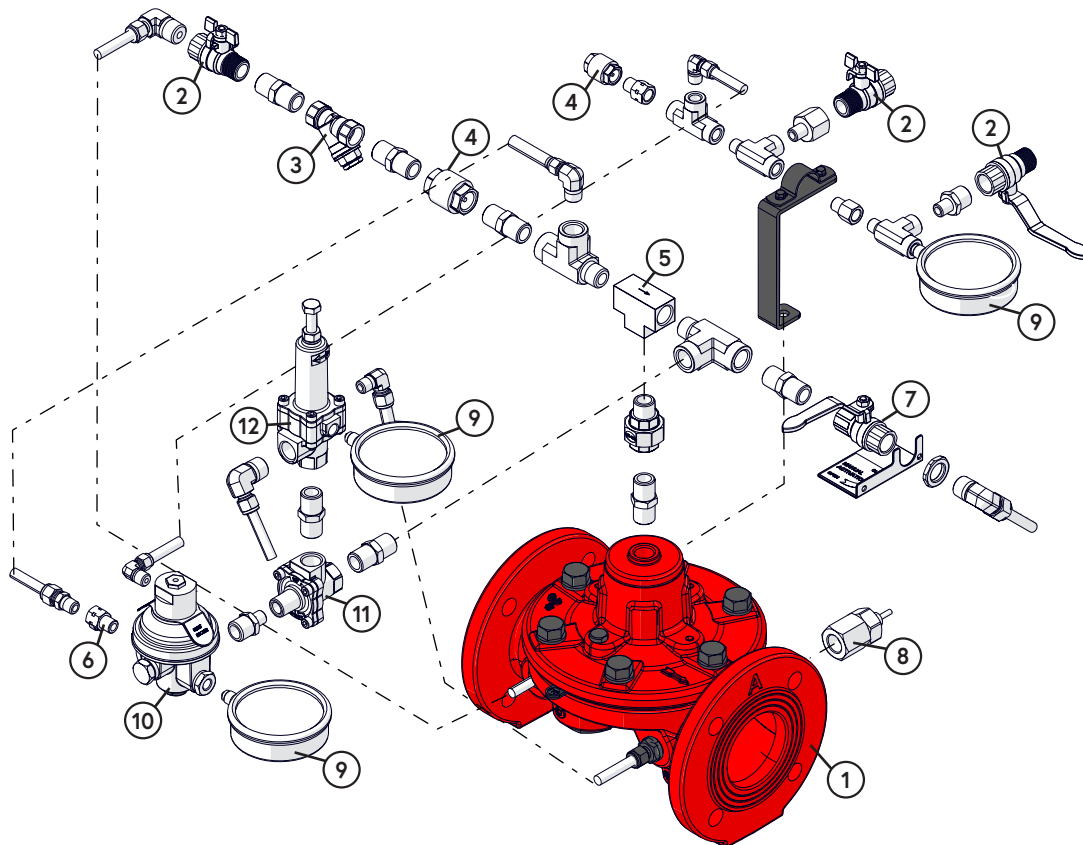

General representation of valve.

General Arrangement & Dimensions

Standard Sizes						
DIM	2"	2 1/2"	3"	4"	6"	8"
A	9 5/8	13 1/8	13 1/8	9 5/8	13 1/8	13 1/8
B	12 3/16	12 3/16	12 3/16	12 3/16	12 3/16	12 3/16
C	8 1/2	8 1/2	8 1/2	8 1/2	8 1/2	8 1/2
D	8 5/16	8 5/16	8 5/16	8 5/16	8 5/16	8 5/16
E	9 5/16	9 5/16	9 5/16	9 5/16	9 5/16	9 5/16
F	3 5/16	3 13/16	3 7/8	3 5/16	3 13/16	3 7/8
G	15 5/16	19	19	16 5/16	19	19

Approximate Dimensions. Flanged ANSI Class #150. Please contact factory for grooved model length availability.

Metric Sizes						
DIM	DN50	DN65	DN80	DN100	DN150	DN200
A	244	334	334	244	334	334
B	311	311	311	311	311	311
C	215	215	215	215	215	215
D	211	211	211	211	211	211
E	235	235	235	235	235	235
F	84	95 1/2	100	84	95 1/2	100
G	414	483	483	414	483	483

Approximate Dimensions. Flanged ANSI Class #150. Please contact factory for grooved model length availability.

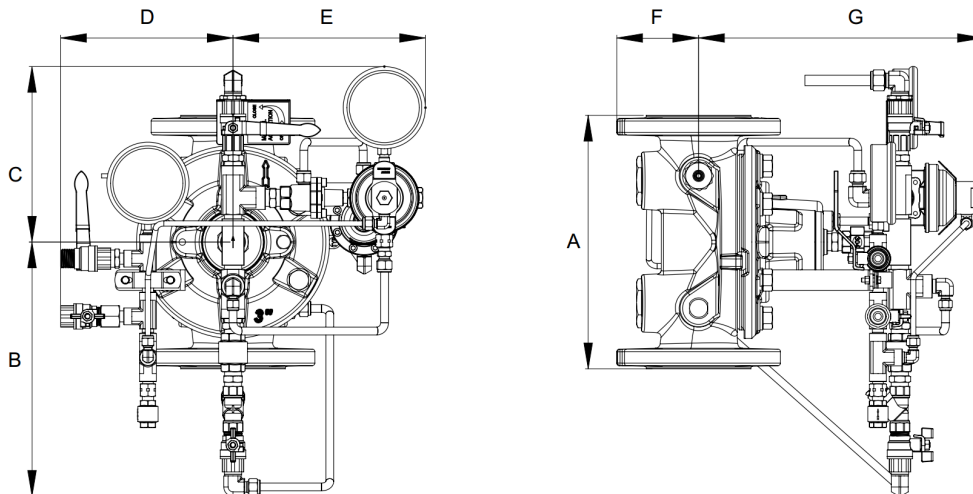

Typical Installation

The typical installation of the OCV 68F DE\PTMR\PRF is as shown:

- | | | | |
|---|--|----|------------------------------|
| 1 | 68F DE\PTMR\PRF Deluge Valve | 8 | Pilot Line - Test Ball Valve |
| 2 | Isolating Valve | 9 | Dry Pilot Line |
| 3 | Y-Type Strainer | 10 | Open Sprinklers/Nozzles |
| 4 | Priming Line Ball Valve | 11 | Closed Sprinklers/Nozzles |
| 5 | PTMR (Pneumatic Touch Manual Reset) Latching Relay | 12 | PPCS |
| 6 | Emergency Manual Actuation Ball Valve | 13 | Pressure Reducing Pilot |
| 7 | Pilot Line - Isolation Ball Valve | | |

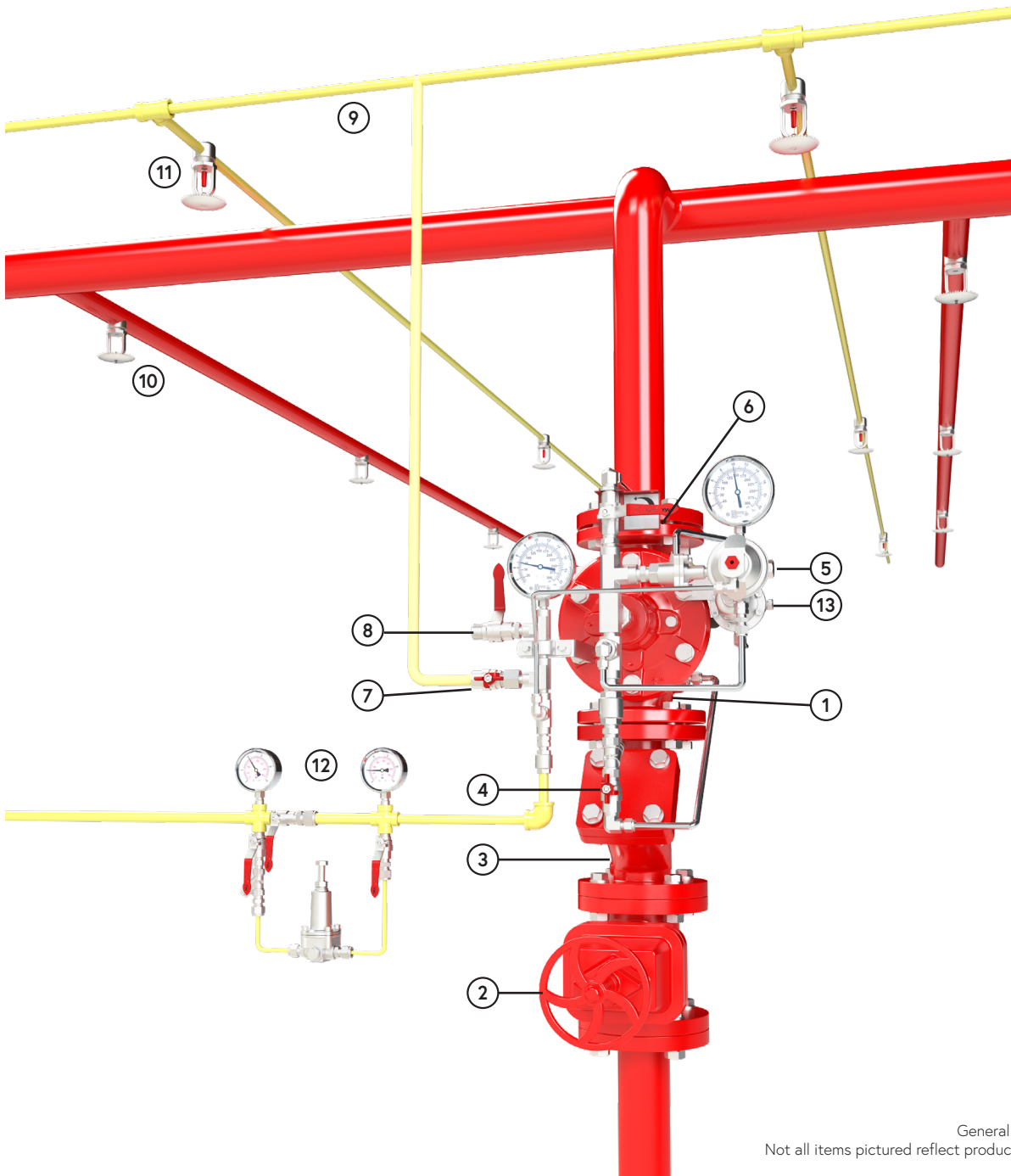

General representation.
Not all items pictured reflect products sold by OCV.

Technical Data

Temperature (Elastomers)	
Media	up to 80°C = 176°F
Elastomers	suitable for extreme climates (available upon request)
Sizes	
FM Approved	2" - 8"
Pressure Rating	
Up to 25 bar \ 375psi	
Minimum system water pressure 1.5 bar \ 22psi	
FM approved working pressures 2" - 8": 25 bar \ 375psi	
End Connections	
Flanged	Sizes: 2" - 8"
	ISO-PN16 & ISO-PN25 ANSI B16.42 & B16.5 Class #150 & #300
Grooved	Sizes: 2" - 8"
	ASME/ANSI AWWA 606
Additional options available upon request	

Body & Cover Material (*Standard)	
Ductile Iron ASTM A536*	Stainless Steel ASTM A351 CF8M
Cast Steel ASTM A216 WCB	Cast Steel ASTM A352 LCB
NAB ASTM B148 gr.C95800	Duplex Stainless Steel
Super Duplex Stainless Steel	Titanium
Trim Material (*Standard)	
Bronze \ Brass*	Nickel Plated Brass
Stainless Steel 316	Super Duplex
MONEL®	Aluminum-Bronze
Tube & Tube Fittings (*Standard)	
Copper \ Bronze \ Brass*	
Stainless Steel 316	Super Duplex
MONEL®	Cu-Ni 90/10
Diaphragm (*Standard)	
NR*	Neoprene
EPDM	NBR
Items to Specify	
Electrical features other than standard (24VDC, IP65/NEMA4)	
If explosion proof accessories are required such as solenoids, pressure switches, etc., please define classification	
Control trim material other than standard	
Required standards, certifications and approvals	

Engineering Specifications

The deluge valve shall be hydraulically operated, direct elastomeric diaphragm-seal, single chamber weir type. The valve shall consist of three major components: the body, the cover and the diaphragm assembly. The diaphragm assembly shall be the only moving part. The diaphragm forms a sealed control chamber in the upper portion of the valve, separating operating pressure from line pressure. Packing glands, stuffing boxes and dynamic o-ring seals are not permitted and there shall not be shafts, discs, bearings or pistons operating the valve. No hourglass shaped disc retainers shall be permitted, and no V-type, U-type or other slotted type disc guides shall be used. The valve shall contain a nylon reinforced rubber diaphragm, elastic & resilient through its entire surface without vulcanized radial seals

and/or reinforcements. The diaphragm assembly shall not be guided by any shafts or bearings and shall not be in close contact with other valve parts except for its sealing surface. The deluge valve shall be fully trimmed, hydrostatically and operationally tested at the factory. Maintenance, disassembly and reassembly of all the valve's components shall be made possible on-site and in-line, without the need to remove the valve from the line. Main valve body and bonnet standard material shall be ductile iron or cast steel. Main valve body and bonnet surfaces shall include a fire red epoxy coating. Other materials and coatings available upon request. The deluge valve shall be an OCV 68F DE\PTMR\PRF, FM Approved, as manufactured by OCV, an Aquestia Ltd. brand, Tulsa, OK, USA.